

SINAMICS G130 Drive Converter Chassis Units SINAMICS G150 Drive Converter Cabinet Units

Catalog D 11 • 2011



SINAMICS Drives

Answers for industry.

SIEMENS

Related catalogs

SINAMICS Drives

SINAMICS G110, SINAMICS G120 Standard Inverters; SINAMICS G110D, SINAMICS G120D Distributed Inverters
E86060-K5511-A111-A6-7600 [D 11.1](#)
E86060-E5511-A111-A1-7600 (News) [D 11.1 N](#)



Motion Control

[PM 21](#)

SIMOTION, SINAMICS S120 and Motors for Productions Machines

E86060-K4921-A101-A2-7600



SINAMICS Drives

[D 21.3](#)

SINAMICS S120 Chassis Format Units and Cabinet Modules
SINAMICS S150 Converter Cabinet Units

E86060-K5521-A131-A2-7600



Low-Voltage Power Distribution and Electrical Installation Technology

[LV 10.1](#)

Protection, Switching, Measuring and Monitoring Devices
E86060-K8250-A101-A1-7600



Motors

IEC Squirrel-Cage Motors
frame sizes 56 to 450
Power 0.06 to 1250 kW
E86060-K5581-A111-A3-7600 [D 81.1](#)
E86060-K5581-A121-A3-7600 (News) [D 81.1 N](#)



SINAMICS Drives

[D 12](#)

SINAMICS GM150, SINAMICS SM150 Medium-Voltage Converters

E86060-K5512-A101-A2-7600



Interactive Catalog CA 01

[CA 01](#)

Products for Automation and Drives

E86060-D4001-A510-C9-7600



Industry Mall

Information and ordering platform in the Internet:
www.siemens.com/industrymall



The Engineering Manual

Engineering Manual SINAMICS Low Voltage
Engineering Manual SINAMICS G130, G150,
S120 Chassis, S120 Cabinet Modules, S150



The Engineering Manual is divided into the following chapters:

- Fundamental Principles and System Description
- EMC design directives
- General Engineering Information for SINAMICS
- Converter Chassis Units SINAMICS G130
- Converter Cabinet Units SINAMICS G150
- SINAMICS S120 Built-in and Cabinet Modules
- Converter Cabinet Units SINAMICS S150
- Drive Dimensioning
- Motors

This manual offers users comprehensive support with the configuring of drives and associated system components. The first three chapters deal mainly with the fundamental physical principles of variable-speed drives and include general system descriptions and general engineering information.

The other chapters then discuss in detail questions relating to the dimensioning of drives as well as the selection of suitable motors.

The Engineering Manual SINAMICS Low Voltage is stored as a PDF file on the CD-ROM supplied with the catalog.

Note:

The manual is not available in hard copy form, but only as an electronic file in PDF format.

CD-ROM for catalog D 11 · 2011

The enclosed CD-ROM for catalog D 11 · 2011 contains the following information on planning/configuration:

- Dimensional drawings for the drive converter chassis units and cabinet units (PDF format)
- Catalog D 11 · 2011, SINAMICS G130/SINAMICS G150 (PDF format)
- Engineering Manual SINAMICS Low Voltage (PDF format)

Hardware and software requirements

- CD-ROM drive
- Windows 2000/XP and higher
- Acrobat Reader
- MS Internet Explorer V5.5 and higher

Start

Insert the CD into the CD-ROM drive. The program starts automatically. If the AutoRun function is not activated in your system, please start the "start.hta" file from the CD-ROM in Windows Explorer.

Note

No programs have to be installed to view the information on this CD-ROM.

SINAMICS Drives

SINAMICS G130 Drive Converter Chassis Units SINAMICS G150 Drive Converter Cabinet Units

Catalog D 11 · 2011



The products and systems described in this catalog are manufactured/distributed under application of a certified quality management system in accordance with DIN EN ISO 9001 and DIN EN ISO 14001 (Certified Registration No. 002241 QM UM). The certificate is recognized by all IQNet countries.

Supersedes:
Catalog D 11 · 2008

Refer to the Industry Mall for current updates of this catalog:

www.siemens.com/industrymall

The products contained in this catalog can also be found in the Interactive Catalog CA 01.

Order No.:
E86060-D4001-A510-C9-7600

Please contact your local Siemens branch

© Siemens AG 2011



Printed on paper from sustainably managed forests and controlled sources.

www.pefc.org

<p>Introduction</p> <p>The SINAMICS drive family The members of the SINAMICS drive family SINAMICS G130 / SINAMICS G150</p>	1
<p>SINAMICS G130 Drive converter chassis units</p>	2
<p>SINAMICS G150 Drive converter cabinet units</p>	3
<p>Tools and configuration</p> <p>SIZER engineering tool STARTER commissioning tool Drive Control Chart (DCC) Drive ES engineering system Configuration</p>	4
<p>Appendix</p> <p>Training Partners at Industry Automation and Drive Technologies Online Services Service & Support Index Conditions of sale and delivery Export regulations</p>	5

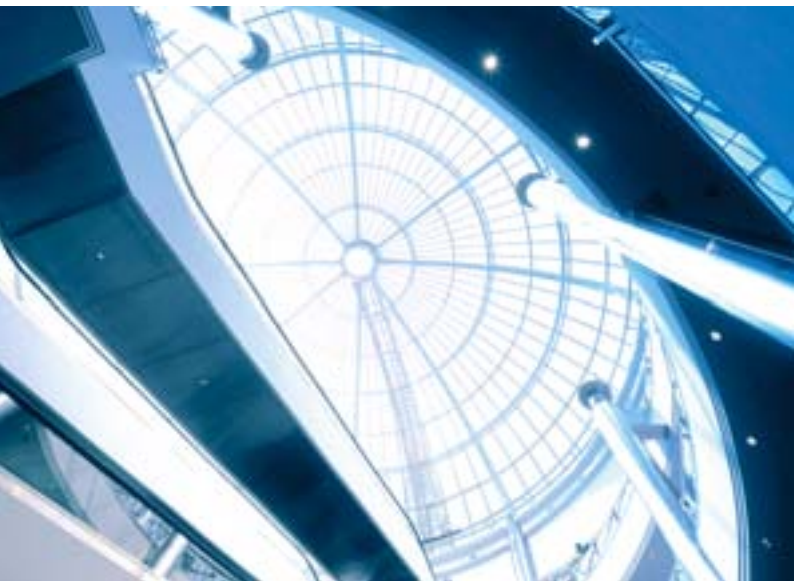
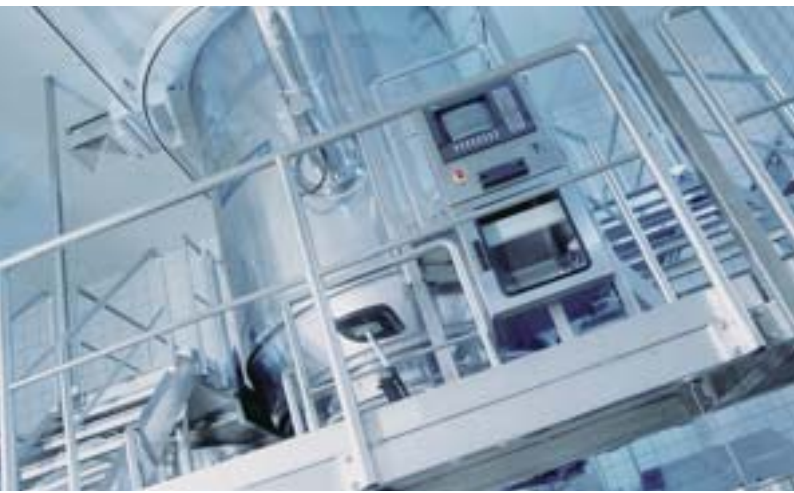



Answers for industry.

Siemens Industry answers the challenges in the manufacturing and the process industry as well as in the building automation business. Our drive and automation solutions based on Totally Integrated Automation (TIA) and Totally Integrated Power (TIP) are employed in all kinds of industry. In the manufacturing and the process industry. In industrial as well as in functional buildings.

Siemens offers automation, drive, and low-voltage switching technology as well as industrial software from standard products up to entire industry solutions. The industry software enables our industry customers to optimize the entire value chain – from product design and development through manufacture and sales up to after-sales service. Our electrical and mechanical components offer integrated technologies for the entire drive train – from couplings to gear units, from motors to control and drive solutions for all engineering industries. Our technology platform TIP offers robust solutions for power distribution.

The high quality of our products sets industry-wide benchmarks. High environmental aims are part of our eco-management, and we implement these aims consistently. Right from product design, possible effects on the environment are examined. Hence many of our products and systems are RoHS compliant (Restriction of Hazardous Substances). As a matter of course, our production sites are certified according to DIN EN ISO 14001, but to us, environmental protection also means most efficient utilization of valuable resources. The best example are our energy-efficient drives with energy savings up to 60 %.

Check out the opportunities our automation and drive solutions provide. And discover how you can sustainably enhance your competitive edge with us.

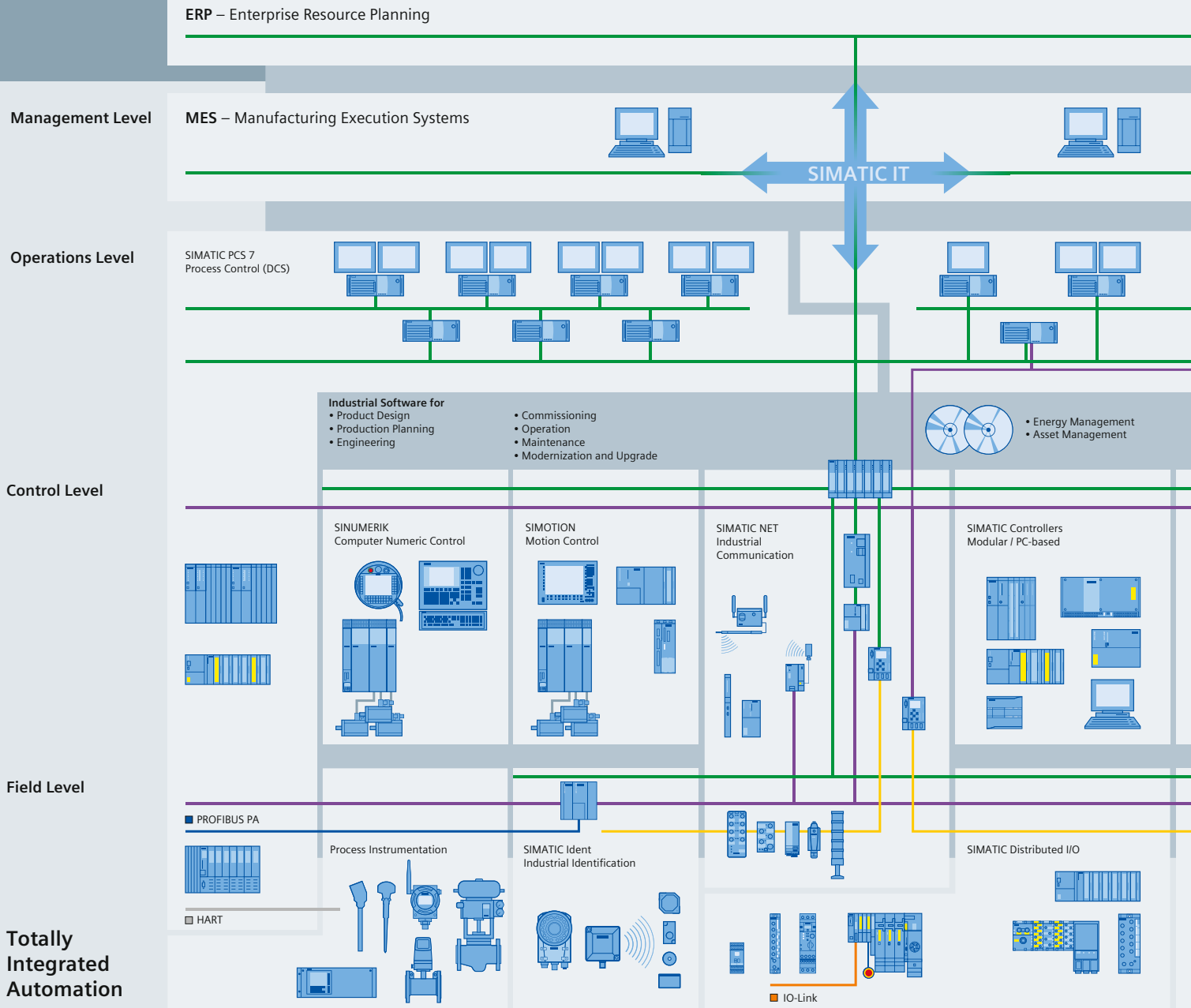

Setting standards in productivity and competitiveness.

Totally Integrated Automation.

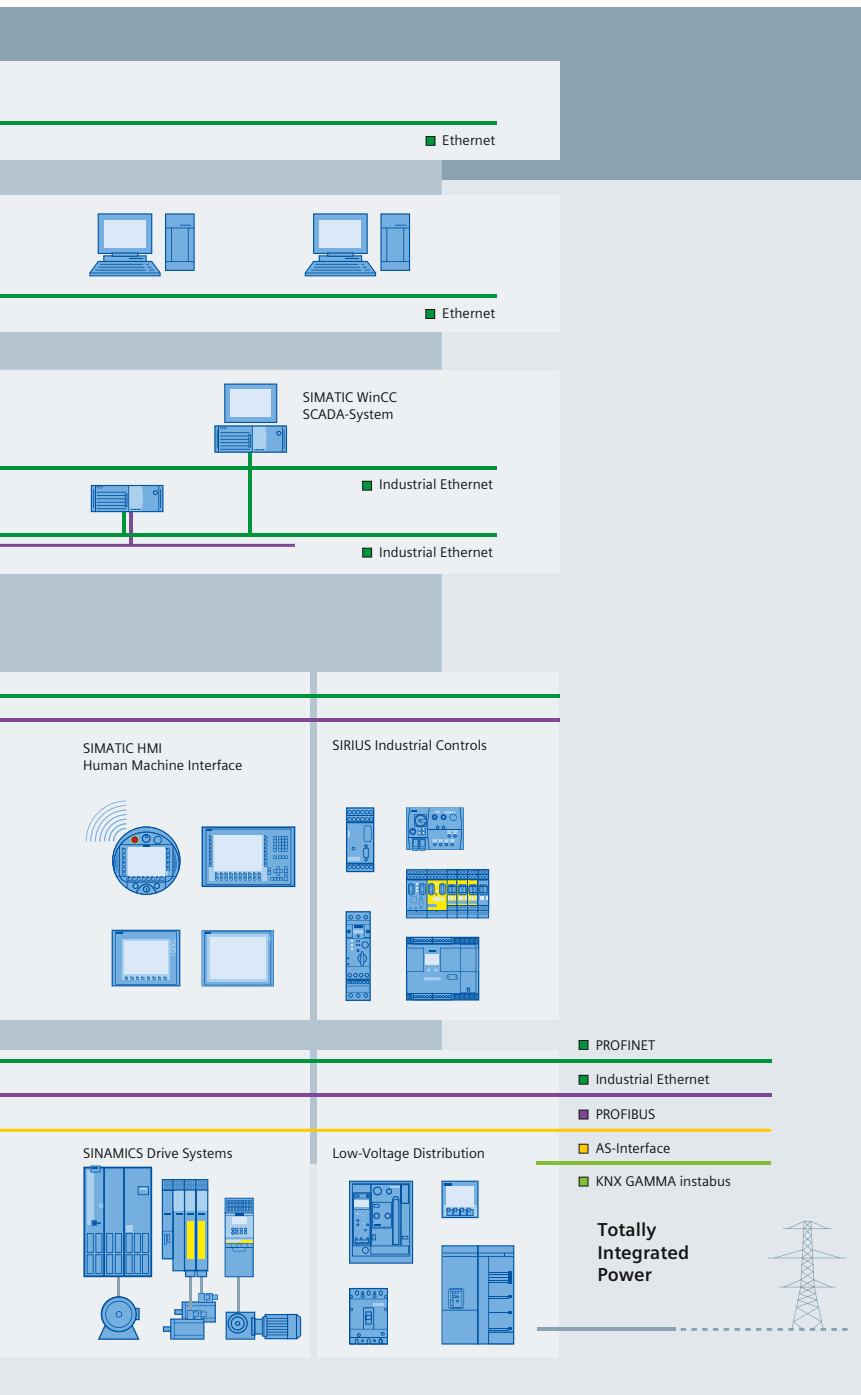

TIA is characterized by its unique continuity.

It provides maximum transparency at all levels with reduced interfacing requirements – covering the field level, production control level, up to the corporate management level. With TIA you also profit throughout the complete life cycle of your plant – starting with the initial planning steps through operation up to modernization, where we offer a high measure of investment security resulting from continuity in the further development of our products and from reducing the number of interfaces to a minimum.

The unique continuity is already a defined characteristic at the development stage of our products and systems.

The result: maximum interoperability – covering the controller, HMI, drives, up to the process control system. This reduces the complexity of the automation solution in your plant. You will experience this, for example, in the engineering phase of the automation solution in the form of reduced time requirements and cost, or during operation using the continuous diagnostics facilities of Totally Integrated Automation for increasing the availability of your plant.

Thanks to Totally Integrated Automation, Siemens provides an integrated basis for the implementation of customized automation solutions – in all industries from inbound to outbound.

Much more than a catalog. The Industry Mall.

You have a catalog in your hands that will serve you well for selecting and ordering your products. But have you heard of the electronic online catalog (the Industry Mall) and all its benefits? Take a look around it sometime:

www.siemens.com/industrymall



Selecting

Find your products in the structure tree, in the new "Bread-crum" navigation or with the integral search machine with expert functions. Electronic configurators are also integrated into the Mall. Enter the various characteristic values and the appropriate product will be displayed with the relevant order numbers. You can save configurations, load them and reset them to their initial status.

Ordering

You can load the products that you have selected in this way into the shopping basket at a click of the mouse. You can create your own templates and you will be informed about the availability of the products in your shopping cart. You can load the completed parts lists directly into Excel or Word.

Delivery status

When you have sent the order, you will receive a short e-mail confirmation which you can print out or save. With a click on "Carrier", you will be directly connected to the website of the carrier where you can easily track the delivery status.

Added value due to additional information

So you have found your product and want more information about it? In just a few clicks of the mouse, you will arrive at the image data base, manuals and operating instructions. Create your own user documentation with My Documentation Manager.

Also available are FAQs, software downloads, certificates and technical data sheets as well as our training programs. In the image database you will find, depending on the product, 2D/3D graphics, dimension drawings and exploded drawings, characteristic curves or circuit diagrams which you can download.

Convinced? We look forward to your visit!

Introduction



1/2	The SINAMICS drive family
1/2	Application
1/2	Variants
1/3	Platform concept and Totally Integrated Automation
1/3	Quality according to DIN EN ISO 9001
1/4	System properties
1/4	Application areas
1/6	The members of the SINAMICS drive family
1/6	Low-voltage converters
1/9	Medium-voltage converters
1/10	DC converters
1/11	SINAMICS G130 / SINAMICS G150
1/11	The universal drive solution for high-performance single-motor drives

Introduction

1

The SINAMICS drive family



Mixers/mills



Plastics



Converting



Machine tools

Pumps/fans/
compressors

Textiles



Packaging



Conveyor systems



Printing machines



Woodworking



Renewable energies

G_D211_EN_00137a

Application areas of the SINAMICS drive family

Application

SINAMICS is the family of drives from Siemens designed for industrial machine and plant construction. SINAMICS offers solutions for all drive tasks:

- Simple pump and fan applications in the process industry
- Complex single-motor drives in centrifuges, presses, extruders, elevators, as well as conveyor and transport systems
- Drive line-ups in textile, plastic film, and paper machines, as well as in rolling mill plants
- High-precision servo drives for the manufacture of wind turbines
- Highly dynamic servo drives for machine tools, as well as packaging and printing machines

Product variants

Depending on the application, the SINAMICS range offers the ideal variant for any drive task.

- SINAMICS G is designed for standard applications with induction motors. These applications have less stringent requirements regarding the dynamic performance of the motor speed.
- SINAMICS S handles demanding drive tasks with synchronous and induction motors and fulfills stringent requirements regarding
 - the dynamic performance and accuracy
 - integration of extensive technological functions in the drive control system.
- SINAMICS DCM is the DC drive belonging to the SINAMICS family. As a result of its expandability across the board, it addresses both basic as well as demanding applications in drive technology and in complementary markets.

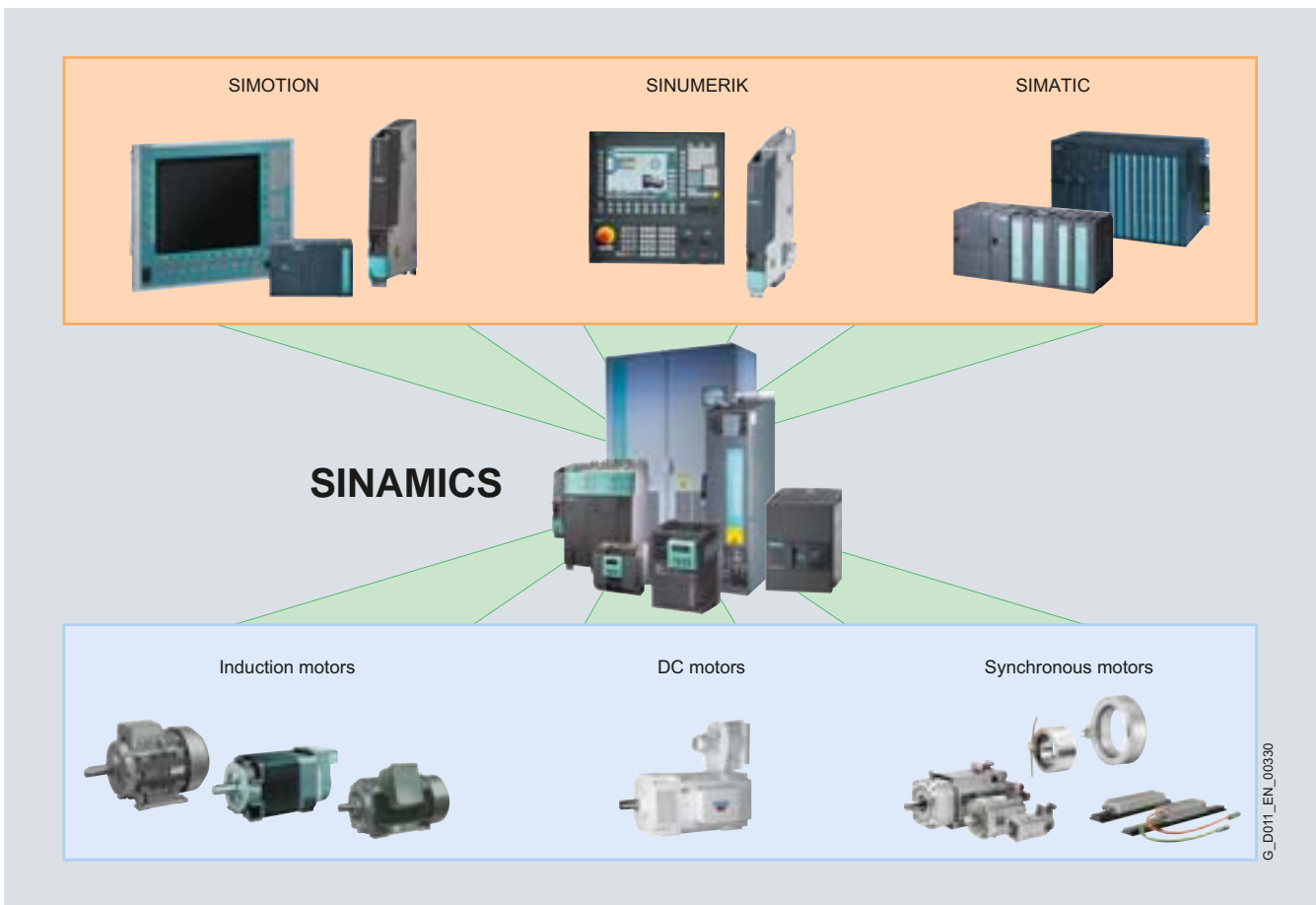

G_D011_EN_00330

SINAMICS as part of the Siemens modular automation system

Platform concept and Totally Integrated Automation

All SINAMICS versions are based on a platform concept. Common hardware and software components, as well as standardized tools for design, configuration and commissioning tasks, ensure high-level integration across all components. SINAMICS handles a wide variety of drive tasks without system gaps. The different SINAMICS versions can be easily combined with each other.

SINAMICS is part of the Siemens "Totally Integrated Automation" concept. Integrated SINAMICS systems covering engineering, data management and communication at the automation level, result in extremely cost-effective solutions based on SIMOTION, SINUMERIK and SIMATIC control systems.

Quality management according to DIN EN ISO 9001



SINAMICS is able to meet the highest quality requirements. Comprehensive quality assurance measures in all development and production processes ensure a consistently high level of quality.

Of course, our quality management system is certified by an independent authority in accordance with DIN EN ISO 9001.

Introduction

The SINAMICS drive family

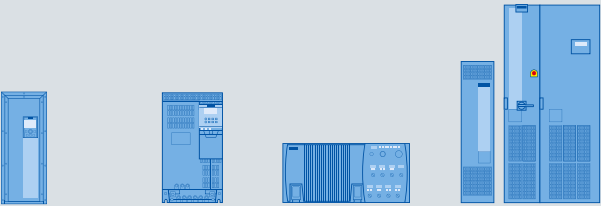
1

Low-Voltage AC Converters								
For basic applications		For high-quality applications				For basic servo drives		
								
SINAMICS G110		SINAMICS G110D		SINAMICS G120P	SINAMICS G120	SINAMICS G120D	SINAMICS G130/G150	SINAMICS S110
V/f Control		V/f Control/FCC		V/f Control / Vector Control				Servo Control
0.12 ... 3 kW		0.75 ... 7.5 kW		0.37 ... 90 kW	0.37 ... 250 kW	0.75 ... 7.5 kW	75 ... 2700 kW	0.12 ... 90 kW
Pumps, fans, conveyor belts		Conveyor technology		Pumps, fans, conveyor belts, compressors, mixers, mills, extruders				Single-axis positioning applications for machine and plant engineering
Common Engineering Tools								
SIZER – for simple planning and configuration					STARTER – for fast commissioning, optimization and diagnostics			

System properties

The SINAMICS range is characterized by the following system properties:

- Standard functionality based on a single platform concept
- Standardized engineering
- High degree of flexibility and combination capability
- Broad power range
- Designed for global use
- SINAMICS Safety Integrated
- Higher efficiency and effectiveness
- High energy efficiency
- Versatile interfacing facilities to higher-level controllers
- Totally Integrated Automation



Application areas

Tailored to suit different application areas, the SINAMICS range encompasses the following products:

AC low-voltage converters (line supply < 1000 V)

- **SINAMICS G110**
- The versatile drive for low power ratings
- **SINAMICS G120P**
- The specialist for pumps, fans, and compressors
- **SINAMICS G120**
- The modular single-motor drive for low up to medium power ratings
- **SINAMICS G110D**
- The distributed, compact single-motor drive in a high degree of protection for basic applications
- **SINAMICS G120D**
- The distributed, modular single-motor drive in a high degree of protection for sophisticated applications
- **SINAMICS G130 and SINAMICS G150**
- The universal drive solution for single-motor drives with a high power rating
- **SINAMICS S110**
- The basic positioning drive for single-axis applications

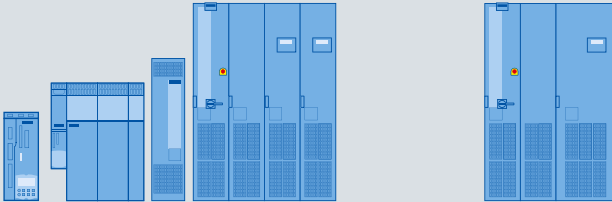
The SINAMICS drive family

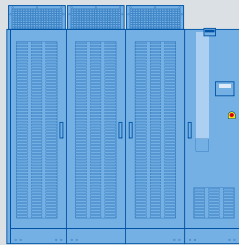
Low-Voltage AC Converters		DC Converters	Medium-Voltage AC Converters
For demanding applications		For basic and demanding applications	For high-power applications
			
SINAMICS S120		SINAMICS DCM	SINAMICS GM150/SM150/GL150/SL150
V/f Control / Vector Control / Servo Control		Closed-loop speed control / torque control	V/f Control / Vector Control
0.12 ... 4500 kW	75 ... 1200 kW	6 kW ... 30 MW	0.8 ... 120 MW
Motion Control applications in production machines (packaging, textile, printing, paper, plastic), machine tools, plants and process lines, metal forming technology, renewable energies	Test stands, cross cutters, centrifuges	Rolling mills, cross cutters and shears, wire-drawing machines, extruders and kneaders, presses, elevator and crane installations, cableways and lifts, mining hoists, test stand drives	Pumps, fans, compressors, mixers, extruders, mills, rolling mills, mining hoist drives, excavators, test stands

G_D023_EN_000686b

Common Engineering Tools

SIZER – for simple planning and configuration

STARTER – for fast commissioning, optimization and diagnostics

Application areas (continued)AC low-voltage converters (line supply voltage < 1000 V)

- **SINAMICS S120**
 - The flexible, modular drive system for demanding drive tasks
- **SINAMICS S150**
 - The drive solution for demanding single-motor drives with a high power rating

DC converter (line supply voltage < 1000 V)

- **SINAMICS DCM**
 - The scalable drive system for basic and demanding applications

AC medium-voltage converters (line supply voltage > 1000 V)

- **SINAMICS GM150**
 - The universal drive solution for single-motor drives
- **SINAMICS SM150**
 - The drive solution for demanding single-motor and multi-motor drives
- **SINAMICS GL150**
 - The drive solution for synchronous motors up to 120 MW
- **SINAMICS SL150**
 - The drive solution for slow speed motors with the highest torques and overloads

Introduction

1

The members of the SINAMICS drive family

SINAMICS low-voltage converters

SINAMICS G110



The versatile single-motor drive for low power ratings

SINAMICS G120P



The specialist for pumps, fans, and compressors

SINAMICS G120



The modular single-motor drive for low up to medium power ratings

Main applications

- Machines and plants for industrial and commercial applications
- Machines and plants in the industrial and commercial areas (heating, climate, ventilation, water/wastewater, process industry, food and beverage industry)
- Machines and plants for industrial and commercial applications (mechanical engineering, automotive, textiles, chemicals, printing, steel)

Application examples

- Pumps and fans
- Auxiliary drives
- Conveyor systems
- Advertisement panels
- Door/gate operating mechanisms
- Pumps
- Fans
- Compressors
- Pumps and fans
- Compressors
- Centrifuges
- Conveyor systems

Highlights

- Compact
- Flexible adaptation to different applications
- Simple and fast commissioning
- Clear terminal layout
- Optimum interaction with SIMATIC and LOGO!
- Modular design for an increased degree of user-friendliness and the flexibility
- Energy efficiency thanks to innovative hardware and software functions
- High degree of usability when commissioning and diagnostics using an innovative operator panel
- Lower harmonics through an innovative topology
- Modular design for a high degree of flexibility and service friendliness
- Energy recovery available instead of a braking resistor
- Safety Integrated
- High degree of usability when commissioning and for diagnostics
- Flexibility through the widest range of communication systems
- Application-specific versions

Catalog D 11.1

Catalog D 11.1 N

Catalog D 11.1

The members of the SINAMICS drive family

1

SINAMICS low-voltage converters

SINAMICS G110D



The distributed, compact single-motor drive for basic applications

SINAMICS G120D



The distributed, single-motor drive for sophisticated applications

SINAMICS G130, SINAMICS G150



The universal drive solution for single-motor drives with a high power rating

Main applications

- Horizontal conveyor applications in the industrial environment, with the main focus on distribution and logistics in airports; generally suitable for basic conveyor-related tasks with local control or connected to a bus via AS-Interface
- Conveyor drive applications in industrial environments, with the main focus on the automotive industry; also suitable for high-performance applications, e.g. at airports and in the food, beverage and tobacco industry (without tenside)
- Machines and plants in the process and production industry, water/waste, power stations, oil and gas, petrochemicals, chemical raw materials, paper, cement, stone, steel

Application examples

- Conveyor systems
- Airports
- Distribution logistics
- Conveyor systems
- Electric overhead-conveyor systems in distribution logistics
- Pumps and fans
- Compressors
- Extruders and mixers
- Mills

Highlights

- Low profile design with uniform drilling dimensions (constant footprint) in IP65 degree of protection
- Simple and fast commissioning
- Optional keyswitch
- AS-Interface bus parameterization
- Quick stop function
- Integrated brake control, 180 V DC
- Optimum interaction with SIMATIC and LOGO!
- Low profile design with uniform drilling dimensions (constant footprint) in IP65 degree of protection
- Modular
- Flexible expansion capability
- Simple and fast commissioning
- Regenerative feedback
- Optimum interaction with SIMOTION and SIMATIC
- SINAMICS Safety Integrated
- Space-saving
- Low noise
- Simple and fast commissioning
- SINAMICS G130: Modular components
- SINAMICS G150: Ready-to-connect cabinet unit
- Optimum interaction with SIMATIC
- SINAMICS Safety Integrated

Catalog D 11.1

Catalog D 11.1

Catalog D 11

Introduction

1

The members of the SINAMICS drive family

SINAMICS low-voltage converters

SINAMICS S110



The basic positioning drive for single-axis applications

SINAMICS S120



The flexible, modular drive system for demanding drive tasks

SINAMICS S150



The drive solution for demanding single-motor drives with a high power rating

Main applications

- Machine and plants in the industrial environment, where machine axes should be quickly and precisely positioned in the simplest possible way.
- Machines and plants for industrial applications (packaging, plastics, textiles, printing, wood, glass, ceramics, presses, paper, lifting equipment, semiconductors, automated assembly and testing equipment, handling, machine tools)
- Machines and plants in the process and production industry, food, beverages and tobacco, automotive and steel industry, mining/open-cast mining, shipbuilding, lifting equipment, conveyors

Application examples

- Handling equipment
- Feed and withdrawal devices
- Stacking units
- Automatic assembly machines
- Laboratory automation
- Metalworking
- Woodworking, glass and ceramic industries
- Printing machines
- Plastics processing machines
- Motion control applications (positioning, synchronous operation)
- Numerical control, interpolating motion control
- Converting
- Technological applications
- Test bay drives
- Centrifuges
- Elevators and cranes
- Cross cutters and shears
- Conveyor belts
- Presses
- Cable winches

Highlights

- For universal use
- Flexible, modular
- Scalable in terms of power, functionality, number of axes, performance
- Simple and fast commissioning, auto-configuration
- Innovative, futureproof system architecture (graded infeed / regenerative feedback concepts)
- Wide range of motors
- (Optimum interaction with SIMOTION, SIMATIC and SINUMERIK)
- SINAMICS Safety Integrated
- For universal use
- Flexible, modular
- Scalable in terms of power, functionality, number of axes, performance
- Simple and fast commissioning, auto-configuration
- Innovative, futureproof system architecture
- Graded infeed/regenerative feedback concepts
- Wide range of motors
- Optimum interaction with SIMOTION, SIMATIC and SINUMERIK
- SINAMICS Safety Integrated
- Four-quadrant operation as standard
- High control accuracy and dynamic performance
- Minimum harmonic effects on the supply system, considerably lower than the limits specified in IEEE 519 THD
- Tolerant to fluctuations in line voltage
- Option of reactive power compensation
- Simple and fast commissioning
- Ready-to-connect cabinet unit
- Optimum interaction with SIMATIC
- SINAMICS Safety Integrated

Catalog PM 22

Catalogs PM 21, D 11.1 and D 21.3

Catalog D 21.3

The members of the SINAMICS drive family

1

SINAMICS medium-voltage converters

SINAMICS GM150



The universal drive solution for single-motor drives

SINAMICS SM150



The drive solution for demanding single-motor and multi-motor drives

SINAMICS GL150



The drive solution for synchronous motors up to 120 MW

SINAMICS SL150



The drive solution for slow speed motors with highest torques and overloads

Main applications

- | | | | |
|---|---|--|--|
| <ul style="list-style-type: none"> • Machines and plants in the process industry | <ul style="list-style-type: none"> • Plant and machines in the steel sector (rolling mills) and mining | <ul style="list-style-type: none"> • Plants and machines in the process industry, especially in the oil, gas and petrochemicals sectors | <ul style="list-style-type: none"> • Plant and machines in the basic materials industry, especially in the steel and mining sectors |
|---|---|--|--|

Application examples

- | | | | |
|---|--|---|---|
| <ul style="list-style-type: none"> • Pumps and fans • Compressors • Extruders and mixers • Mills • Marine drives | <ul style="list-style-type: none"> • Hot and cold rolling mill stands • Mine hoists • Test bay drives • Ore conveyor belts | <ul style="list-style-type: none"> • Compressors • Pumps and fans • Extruders and mixers • Marine drives • Blast furnace blowers | <ul style="list-style-type: none"> • Hot rolling mill roughing stands • Mine hoists • Ore and cement mills • Excavators |
|---|--|---|---|

Highlights

- | | | | |
|--|---|--|---|
| <ul style="list-style-type: none"> • Space-saving • Simple and fast commissioning • Ready-to-connect cabinet unit • Optimum interaction with SIMATIC | <ul style="list-style-type: none"> • Four-quadrant operation as standard • High efficiency and minimum load on the motor • High control accuracy and dynamic performance • Almost free of line-current harmonics • Option of reactive power compensation • Simple and fast commissioning • Ready-to-connect cabinet unit • Optimum interaction with SIMATIC | <ul style="list-style-type: none"> • Compact design and high power density • Easy operation and monitoring • Extremely rugged, reliable and almost maintenance-free • Two directions of rotation by reversing the rotating field • Capable of seamless integration into higher-level automation systems | <ul style="list-style-type: none"> • Low output frequency/motor speed • High short-time overload capability • Four-quadrant operation as standard • Extremely rugged, reliable and almost maintenance-free • High efficiency • Capable of seamless integration into higher-level automation systems |
|--|---|--|---|

Catalog D 12

Catalog D 12

-

-

Introduction

1

The members of the SINAMICS drive family

SINAMICS DC converters

SINAMICS DCM



The scalable drive system for basic and demanding applications

Main applications

- Machines and plants in the industrial environment (steel/aluminum, plastics, printing, paper, cranes, mining, oil and gas, excitation equipment) in the new plant and retrofit businesses

Application examples

- Rolling mills
- Cross cutters and shears
- Wire-drawing machines
- Extruders and mixers
- Presses
- Elevators and cranes
- Cableways and lifts
- Mine hoists
- Test bay drives

Highlights

- PROFIBUS as standard, PROFINET optional
- Variance of the Control Units
- Field power supply in-line with requirements
- Electronics power supply for connection to 24 V DC
- Power unit isolated with respect to ground
- Free function blocks and Drive Control Chart
- Expandable functionality using SINAMICS components
- Single-phase connection possible
- Varnished PCBs and nickel-plated copper busbars
- Wide temperature range

Catalog D 23.1

Introduction

SINAMICS G130 / SINAMICS G150

The universal drive solution
for single-motor drives with a high power rating

1

Overview



SINAMICS G130 drive converter chassis units and SINAMICS G150 drive converter cabinet units are designed for variable-speed drives in machine building and plant construction.

They have been specially tuned to the requirements of drives with quadratic and constant load characteristics, with medium performance requirements and without regenerative feedback.

The control accuracy of the sensorless vector control is suitable for most applications, and additional actual speed value encoders are therefore superfluous.

However, SINAMICS G130/SINAMICS G150 converters are optionally available with an encoder evaluation function in order to handle applications that require an encoder for system-specific reasons.

SINAMICS G130 and SINAMICS G150 offer an economic drive solution that can be matched to customers' specific requirements using the wide range of available components and options.

Benefits

- Particularly quiet and compact converters due to the use of state-of-the-art IGBT power semiconductors and an innovative cooling concept.
- All unit modules are easily accessible, making them extremely service-friendly.
- Can be easily integrated into automation solutions using the PROFIBUS interface supplied as standard and various analog and digital interfaces
- Increase in plant availability since individual modules and power components can be replaced quickly and easily.
- Easy commissioning and parameterization using interactive menus on the AOP30 Advanced Operator Panel with graphical LCD and plain-text display.

Application

Variable-speed drives are ideal for all applications that involve moving, conveying, pumping or compressing solids, liquids or gases.

This means the following applications in particular:

- Pumps and fans
- Compressors
- Extruders and mixers
- Mills

Design

SINAMICS G130

SINAMICS G130 provides machine builders and plant construction companies with a modular drive system that can be tailored to specific applications.

SINAMICS G130 essentially consists of two modular, stand-alone components

- Power Module and
- Control Unit

They may be located separately from one another or combined in a single unit. The Power Module contains a slot for the Control Unit.

The user-friendly AOP30 operator panel can be used for commissioning and local operation.

Predefined interfaces, via terminal block or the CU320-2 Control Unit with either PROFIBUS or PROFINET, make commissioning and control of the drive much easier. The Control Unit interfaces can be supplemented with add-on modules.

SINAMICS G150

SINAMICS G150 is a ready-to-connect AC/AC converter in the standard control cabinet.

They can be matched to individual requirements by selecting from an extensive range of options.

They are available in widths from 400 mm, which then increase in intervals of 200 mm; they can be ordered with various degrees of protection up to IP54 in two design versions.

- **Version A**
offers sufficient space for installing all of the available options. With the different versions, the line and motor connections can be located on the top or the bottom, which in turn offers excellent flexibility in terms of location in the plant. This version is also available with power sections connected in parallel.
- **Version C**
is a particularly space-saving version envisaged for applications where the power supply components are accommodated in a central low-voltage distribution unit and need not be provided again in the control cabinet.

The AOP30 Advanced Operator Panel is fitted as standard in the cabinet door for both versions.

Introduction

SINAMICS G130 / SINAMICS G150

The universal drive solution for single-motor drives with a high power rating

1

Integration

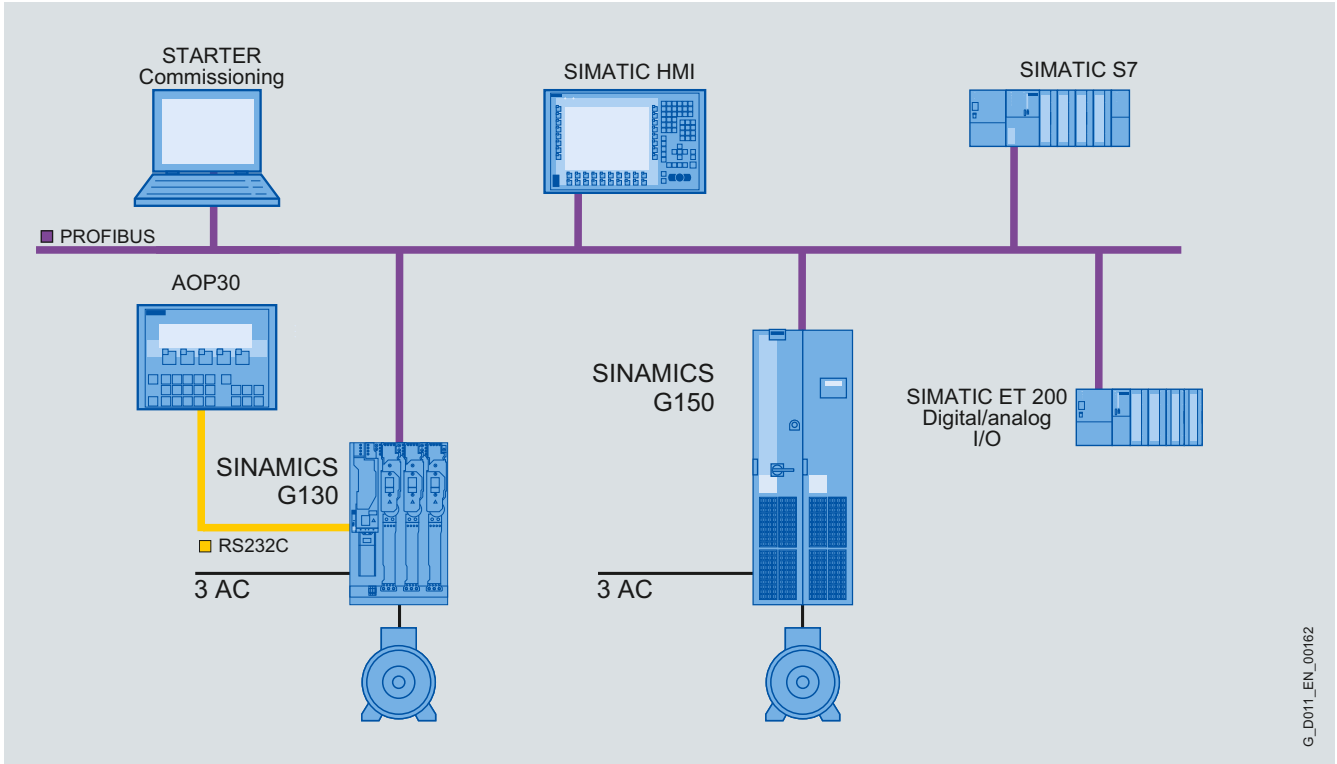

SINAMICS G130 and SINAMICS G150 configuration example with SIMATIC S7

G_D011_EN_00162

SINAMICS G130

Drive converter chassis units



2/2	Overview	2/14	Power Modules
2/3	Benefits	2/22	Line-side power components
2/3	Application	2/22	Line filters
2/3	Documentation	2/25	Line Harmonics Filters
2/3	Design	2/27	Line reactors
2/3	Design	2/32	Recommended line-side system components
2/6	Function	2/34	DC link components
2/6	Communication with higher-level control and customer Terminal Module	2/34	Braking Modules
2/6	Open-loop and closed-loop control functions	2/37	Braking resistors
2/6	Software and protective functions	2/39	Load-side power components
2/6	Power unit protection	2/39	Motor reactors
2/7	Safety Integrated functions	2/43	dv/dt filters plus VPL
2/9	Technical data	2/48	dv/dt filters compact plus VPL
2/10	General technical data	2/52	Sine-wave filters
2/11	Characteristic curves	2/54	Control Unit Kit CU320-2 DP (PROFIBUS)
2/11	Derating data	2/57	Control Unit Kit CU320-2 PN (PROFINET)
2/13	Overload capability	2/60	Supplementary system components
		2/60	BOP20 Basic Operator Panel
		2/61	AOP30 Advanced Operator Panel
		2/63	CBC10 Communication Board
		2/64	CBE20 Communication Board
		2/65	TB30 Terminal Board
		2/67	TM31 Terminal Module
		2/70	VSM10 Voltage Sensing Module
		2/72	SMC30 Sensor Module Cabinet-Mounted
		2/73	MOTION-CONNECT connection system
		2/73	Signal cables

SINAMICS G130

Drive converter chassis units

75 kW to 800 kW

Overview



SINAMICS G130 drive converter chassis units in frame sizes FX + HX

The SINAMICS G130 is a converter that can be combined very flexibly with the associated system components and integrated into customer-specific control cabinets or directly into machines.

The SINAMICS G130 drive converter chassis units are available for the following voltages and power ratings:

Line voltage	Power
380 ... 480 V 3 AC	110 ... 560 kW
500 ... 600 V 3 AC	110 ... 560 kW
660 ... 690 V 3 AC	75 ... 800 kW

A wide range of add-on electrical components allow the drive system to be optimized for specific requirements. Configuration and commissioning are greatly simplified by predefined interfaces.

The control accuracy of the sensorless vector control is suitable for most applications, and additional actual speed value encoders are therefore superfluous.

However, encoder evaluation units are available for the SINAMICS G130 converters so that they can address applications that require an encoder for plant-specific reasons.

Communication between the Control Unit, the Power Module and other active SINAMICS components takes place via DRIVE-CLiQ, the drive's internal interface. The DRIVE-CLiQ connections, which are available as pre-assembled cables of different lengths, allow a complete converter system to be put together quickly.

For communication with the process control system, with the CU320-2 either a PROFIBUS or a PROFINET interface is available as standard. There is also the option to expand the interface using digital and analog inputs and outputs. The TM31 Terminal Module and TB30 Terminal Board are provided for this purpose. Additional expansion cards can also be installed to allow communication via PROFINET and the CAN protocol.

Benefits

- Particularly quiet and compact converters due to the use of state-of-the-art IGBT power semiconductors and an innovative cooling concept.
- Individual modules and power components can be replaced quickly and easily, which ensures a higher level of plant availability. The design of replaceable components is based on the principle that they must be quick and easy to change. In addition, the "SparesOnWeb" Internet tool makes it easy to view the spare parts that are available for the system components ordered.
- Can be easily integrated in automation solutions by means of a standard communications interface as well as a range of analog and digital interfaces.
- Easy commissioning and parameterization using interactive menus on the AOP30 Advanced Operator Panel with graphic LCD and plain-text display, or from a PC using the STARTER commissioning tool (→Tools and configuration).
- Preset software functions make it easier to tailor the converter to the individual plant.
- All components, from individual parts to the ready-to-connect cabinet, undergo rigorous testing throughout the entire production process. This guarantees a high level of functional reliability during installation and commissioning, as well as in operation.

Application

Variable-speed drives are ideal for all applications that involve moving, conveying, pumping or compressing solids, liquids or gases.

This means the following applications in particular:

- Pumps and fans
- Compressors
- Extruders and mixers
- Mills

Documentation

The documentation for the various drive units consists of the following parts:

- Operating instructions
- Spare parts list
- Unit-specific dimension drawings, layout diagrams, circuit and terminal diagrams

The documentation is supplied as standard with the CU Kit on CD-ROM. The documentation is available in English, French, German, Italian and Spanish.

Design

The SINAMICS G130 drive converter chassis unit provides machine builders and plant constructors with a modular drive system that can be tailored to specific applications.

SINAMICS G130 drive converter chassis units consist of two modular, stand-alone components:

- Power Module and
- Control Unit

They may be located separately from one another or combined in a single unit. The Power Module contains a slot for the Control Unit.

The Power Modules are supplied with a DRIVE-CLiQ cable for communication and a cable for the 24 V supply to the Control Unit. These cables are pre-assembled for installing the Control Unit in the Power Module. If the two units are installed in separate locations, the cables must be ordered in the appropriate lengths.

The AOP30 Advanced Operator Panel and the BOP20 Basic Operator Panel can be used for commissioning and local operation.

Predefined interfaces, via terminal block or the CU320-2 Control Unit with either PROFIBUS or PROFINET, make commissioning and control of the drive much easier. The interfaces of the CU320-2 Control Unit can be supplemented with add-on modules, such as the plug-in TB30 Terminal Module or the TM31 Terminal Module.

If further customer interfaces are needed to communicate with the drive, an external 24 V supply must be provided.

The two figures in the following pages are helpful when it comes to assembling the required converter components correctly.

The first figure shows the design and individual components of a SINAMICS G130 drive.

The second figure is a flowchart containing the decision and selection criteria required for the individual components.

Varnished PCBs

The following converter components are equipped as standard with varnished PCBs:

- Power Modules
- Control Units
- Sensor Modules
- Terminal Modules
- Advanced Operator Panel (AOP30)

The coating on the modules protects the sensitive SMD components against corrosive gases, chemically active dust and moisture.

Nickel-plated busbars

All of the copper busbars of the Power Modules are nickel-plated in order to achieve the best possible immunity to environmental effects. Further, the bare copper connections do not have to be cleaned for customer connections.

SINAMICS G130

Drive converter chassis units

75 kW to 800 kW

Design (continued)

2

3 AC supply

Line-side power components
e.g.

- Switch disconnectors
- Line contactors
- Line filters
- Line reactors
- Line harmonics filters

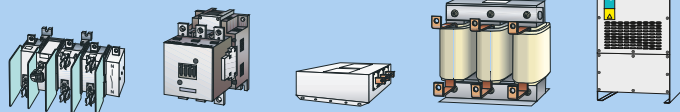

Connection system

Signal cables

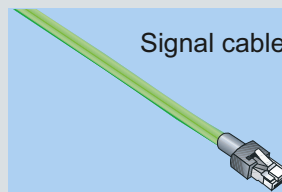

SINAMICS G130 components

Power Modules

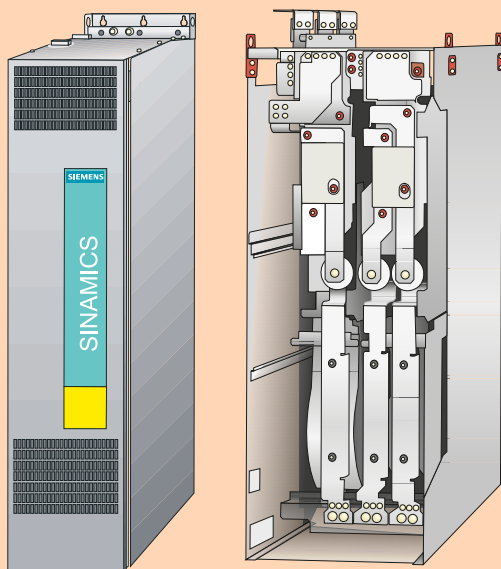

Control Unit Kit

CU320-2 Control Unit
with CompactFlash card



Supplementary system components
e.g.

- Terminal Board
- Terminal Module
- Sensor Module
- Advanced Operator Panel
- PROFINET board
- CANopen board

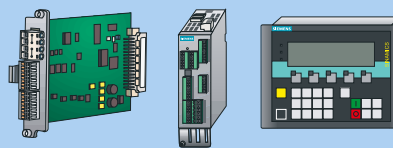

DC link components

Braking Modules
with braking resistors

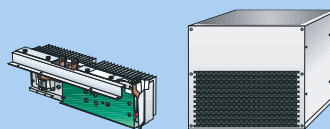

Motor-side power components

- Motor reactors
- Sine-wave filters
- dv/dt-filter plus VPL
- dv/dt-filter compact plus VPL

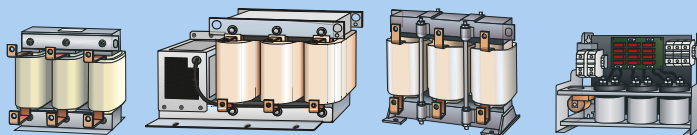

Motors

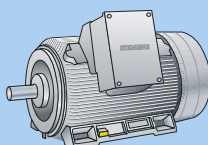

Design (continued)

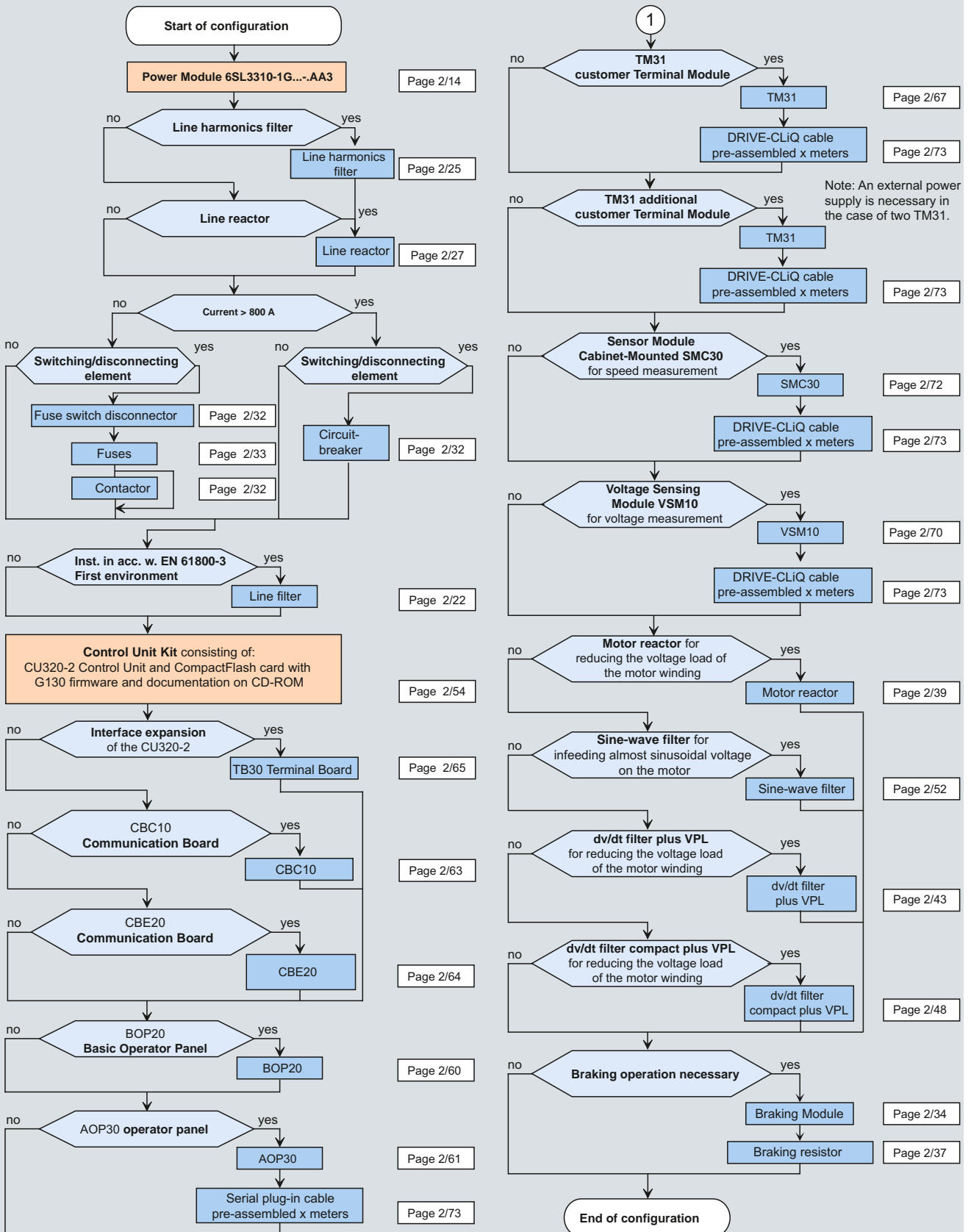

G_D011_EN_00129b

1

2

SINAMICS G130

Drive converter chassis units

75 kW to 800 kW

Function

Communication with higher-level control and customer Terminal Module

A communications interface on the CU320-2 Control Unit, the TM31 Terminal Module, the TB30 Terminal Board and expansions for supporting PROFINET and CANopen are provided as standard as the customer control interface.

This customer Terminal Module can be used to connect the system to the higher-level controller using analog and digital signals, or to connect additional units.

To simplify configuration and commissioning of the drive, the TM31 Terminal Module can be preset to a variety of factory settings.

The SINAMICS Low Voltage Engineering Manual contains additional information and is stored as a PDF file on the CD-ROM included with the catalog.

Open-loop and closed-loop control functions

The converter control contains a high-quality vector control with speed and current controls as well as motor and converter protection.

Software and protective functions

The software functions available as standard are described below:

Software and protective functions	Description
Setpoint input	The setpoint can be input both internally and externally. It is applied internally as a fixed setpoint, motorized potentiometer setpoint or jog setpoint and externally via the communications interface or an analog input on the customer Terminal Module. The internal fixed setpoint and the motorized potentiometer setpoint can be switched over or adjusted using control commands via all interfaces.
Motor identification	The automatic motor identification function makes commissioning faster and easier and optimizes closed-loop control of the drive.
Ramp-function generator	A convenient ramp-function generator with separately adjustable ramping times, together with adjustable rounding times in the lower and upper speed ranges, allows the drive to be smoothly accelerated and braked. As a consequence, this avoids the drive train from being overloaded and reduces the stress on mechanical components. The down ramps can be parameterized separately for quick stop.
V_{dc max} controller	The V _{dc max} controller automatically prevents overvoltages in the DC link if the set down ramp is too short, for example. This may also extend the set ramp-down time.
Kinetic buffering (KIP)	For supply voltage dips the kinetic energy of the rotating drive is used to buffer the DC link and therefore prevents fault trips. The drive converter remains operational as long as the drive can provide regenerative energy as a result of its motion and the DC link voltage does not drop below the trip threshold. When the line supply recovers within this time, the drive is again accelerated up to its setpoint speed.
Automatic restart ¹⁾	The automatic restart switches the drive on again when the power is restored after a power failure, and ramps up to the current speed setpoint.
Flying restart ¹⁾	The "Flying restart" function allows the converter to be switched to a motor that is still turning.
Technology controller	The "Technology controller" function module allows simple control functions to be implemented, e.g. level control or volumetric flow control. The technology controller is designed as a PID controller, whereby the differentiator can be switched to the control deviation channel or the actual value channel (factory setting). The P, I, and D components can be set separately.
Free function blocks	Using the freely programmable function blocks, it is easy to implement logic and arithmetic functions for controlling the SINAMICS G130 unit. The blocks can be programmed by means of an operator panel or the STARTER commissioning tool.
Drive Control Chart (DCC)	Drive Control Chart (DCC) is an additional tool for the easy configuration of process-oriented functions for the SINAMICS G130. The block library contains a large selection of control, arithmetic and logic blocks as well as extensive open-loop and closed-loop control functions. The user-friendly DCC editor enables easy graphical configuration and a clear representation of control loop structures as well as a high degree of reusability of existing diagrams. DCC is an add-on to the STARTER commissioning tool (→Tools and configuration).
Rt detection for motor protection	A motor model stored in the converter software calculates the motor temperature based on the current speed and load. More exact sensing of the temperature, which also takes into account the influence of the ambient temperature, is possible by means of direct temperature sensing using KTY84 sensors in the motor winding.
Motor temperature evaluation	Motor protection by evaluating a KTY84, PTC or PT100 temperature sensor. When a KTY84 sensor is connected, the limit values can be set for alarm or shutdown. When a PTC thermistor is connected, the system reaction to triggering of the thermistor (alarm or shutdown) can be defined.
Motor blocking protection	A blocked motor is recognized and protected against thermal overloading by shutting down.
Power unit protection	Description
Ground fault monitoring at output end	A ground fault on the output side is detected by an aggregate current monitor and results in shutdown in grounded-neutral systems.
Electronic short-circuit protection at output end	A short-circuit at the output (e.g. at the converter output terminals, in the motor cable or in the motor terminal box) is detected and the converter shuts down with a "fault".
Thermal overload protection	An alarm is issued first when the overtemperature threshold responds. If the temperature rises further, the unit either shuts down or independently adjusts the pulse frequency or output current so that a reduction in the thermal load is achieved. Once the cause of the fault has been eliminated (e.g. cooling has been improved), the original operating values are automatically resumed.

¹⁾ Factory setting: not activated (can be programmed)

Function (continued)

Safety Integrated functions

The integrated safety functions of SINAMICS provide highly-effective application-oriented protection for personnel and machinery.

SINAMICS G130 offers the following Safety Integrated functions as standard (terms as defined in IEC 61800-5-2):

- Safe Torque Off (STO)
- Safe Stop 1 (SS1)

The Safety Integrated functions are implemented electronically and therefore offer short response times in comparison to solutions with externally implemented monitoring functions.

Legal framework

Machine manufacturers and plant construction companies must ensure that their machines or plants cannot cause danger as a result of electric shock, heat or radiation or hazards caused by functional faults. In Europe, for example, compliance with the machinery directive is legally stipulated by the EU industrial safety directive.

In order to ensure compliance with this directive, it is recommended that the corresponding harmonized European standards are applied. This initiates the assumption of conformity and gives manufacturers and operators the legal security when complying with both national regulations and EU directives. The machine manufacturer uses the CE marking to document the compliance with all relevant directives and regulations in the free movement of goods.

Safety-related standards

Functional safety is specified in various standards.

EN ISO 12100 and EN ISO 14121-1, for example, are concerned with the design and risk assessment of machines. Functional and safety-related requirements of control systems with relevance to safety are defined in EN 62061 (applicable only to electrical and electronic control systems) and EN ISO 13849-1. This will replace EN 954-1 – which is still being commonly used – at the end of 2011.

The above-mentioned standards define different safety requirements that the machine has to satisfy in accordance with the risk, frequency of a dangerous situation, probability of occurrence and the opportunities for recognizing impending danger.

- EN 954-1: Categories B, 1 ... 4
- EN ISO 13849-1: Performance Level PL a ... e
- EN 62061: Safety Integrity Level SIL 1 ... 3

Safety functions integrated in the drive with SINAMICS

The safety functions integrated in SINAMICS satisfy the requirements of:

- Category 3 according to EN 954-1 or EN ISO 13849-1
- Safety Integrity Level (SIL) 2 according to EN 61508
- Performance Level (PL) d according to EN ISO 13849-1

In addition, the Safety Integrated functions of SINAMICS are generally certified by independent institutes. An up-to-date list of certified components is available on request from your local Siemens office.

Basic Functions and Extended Functions

The Safety Integrated functions of the SINAMICS drive system are grouped into basic functions and extended functions.

The above mentioned Basic Functions STO and SS1 are included in the standard scope of SINAMICS G130 and do not require a license. Extended Functions, which will require a license, are presently still not available for SINAMICS G130.

The Safety Integrated functions are either activated via a terminal at the Control Unit and at the power unit, or via PROFIBUS or PROFINET with the PROFIsafe profile.

An encoder is not required to use Basic Functions.

The Safety Integrated functions currently available in SINAMICS G130 are subsequently described in more detail (terms as defined in IEC 61800-5-2):

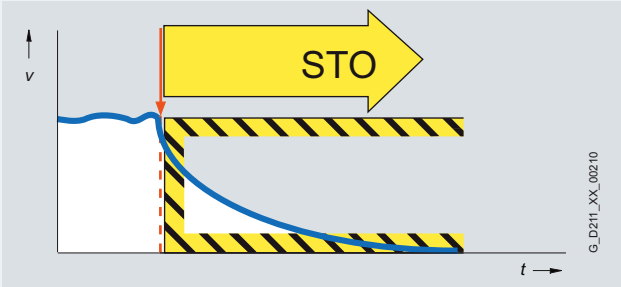
Safety Integrated	Description
Safe Torque Off (STO)	<p><u>Function description</u></p> <p>This function is a mechanism that prevents the drive from restarting unexpectedly, in accordance with EN 60204-1, Section 5.4. Safe Torque Off disables the drive pulses and disconnects the power supply to the motor (corresponds to Stop Category 0 of EN 60204-1). The drive is reliably torque-free. This state is monitored internally in the drive.</p> <p><u>Application, customer benefits</u></p> <p>STO has the immediate effect that the drive cannot supply any torque-generating energy. STO can be used wherever the drive will reach a standstill by itself due to the load torque or friction in a sufficiently short time or when "coasting down" of the drive will not have any relevance for safety.</p> 

SINAMICS G130

Drive converter chassis units

75 kW to 800 kW

Function (continued)**Safety Integrated****Description****Safe Stop 1 (SS1)**Function description

The Safe Stop 1 function can safely stop the drive in accordance with EN 60204-1, Stop Category 1. When the SS1 function is selected, the drive independently brakes along a quick stop ramp (OFF3) and automatically activates Safe Torque Off when the parameterized safety delay time Δt has expired.

Application, customer benefits

With this integrated self-braking function, complex external monitoring devices are not required. It is often possible to also eliminate mechanical brakes which wear – or to lessen the load on them, so that maintenance costs and the stresses on the machine can be reduced. Safe Stop 1 is employed for applications which require monitored braking, e.g. on centrifuges or conveyor vehicles.

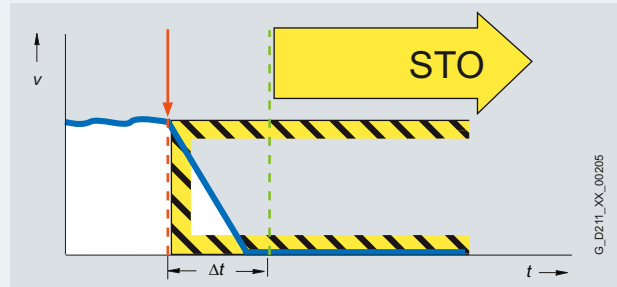

Technical data

The most important directives and standards are listed below. These are used as basis for the SINAMICS drive system and they must be carefully observed to achieve an EMC-compliant configuration that is safe both functionally and in operation.

European directives

2006/95/EC	Low-voltage directive: Legal guidelines of the EU member states concerning electrical equipment for use within specified voltage limits
2004/108/EC	EMC directive: Legal guidelines of the EU member states for electromagnetic compatibility

European Standards

EN 954-1	Safety of machinery – Safety-related parts of controls Part 1: General design principles
EN ISO 13849-1	Safety of machinery – Safety-related parts of controls Part 1: General design principles (ISO 13849-1:2006) (replaced EN 954-1)
EN 60146-1-1	Semiconductor converters – General requirements and line-commutated converters Part 1-1: Specification of basic requirements
EN 60204-1	Electrical equipment of machines Part 1: General requirements
EN 60529	Degrees of protection provided by enclosures (IP code)
EN 61508-1	Functional safety of electrical/electronic/programmable electronic safety-related systems Part 1: General requirements
EN 61800-2	Adjustable speed electrical power drive systems Part 2: General requirements – Rating specifications for low-voltage adjustable frequency AC power drive systems
EN 61800-3	Adjustable speed electrical power drive systems Part 3: EMC requirements and specific test methods
EN 61800-5-1	Adjustable speed electrical power drive systems Part 5: Safety requirements Main section 1: Electrical and thermal requirements
EN 61800-5-2	Adjustable speed electrical power drive systems Part 5-2: Safety requirements – Functional safety (IEC 61800-5-2:2007)

North American standards

UL508A	Industrial Control Panels
UL508C	Power Conversion Equipment
CSA C22.2 No. 14	Industrial Control Equipment

Approvals

cULus, cURus	Testing by UL (Underwriters Laboratories, http://www.ul.com) according to UL and CSA standards
--------------	---

Test symbol:

(→ Appendix, Approvals)

SINAMICS G130

Drive converter chassis units

75 kW to 800 kW

Technical data (continued)**General technical data**

Electrical data				
Line voltages and output ranges	• 380 ... 480 V 3 AC, ±10 % (-15 % < 1 min)	110 ... 560 kW		
	• 500 ... 600 V 3 AC, ±10 % (-15 % < 1 min)	110 ... 560 kW		
	• 660 ... 690 V 3 AC, ±10 % (-15 % < 1 min)	75 ... 800 kW		
Types of supplies	Grounded TN/TT systems or ungrounded IT systems (a grounded phase conductor is not permissible in 690 V systems)			
Line frequency	47 ... 63 Hz			
Output frequency	0 ... 650 Hz			
Power factor				
- Fundamental mode	> 0.96			
- Total	0.75 ... 0.93			
Efficiency	> 98 %			
Overvoltage category	III to EN 61800-5-1			
Rated short-circuit current SCCR (Short Circuit Current Rating) according to UL508C (up to 600 V), in conjunction with the specified fuses or circuit breakers	• Rated power 1.1 ... 447 kW	65 kA		
	• Rated power 448 ... 671 kW	84 kA		
	• Rated power 672 ... 1193 kW	170 kA		
	• Rated power >1194 kW	200 kA		
Control method	Vector control with and without encoder or V/f control			
Fixed speeds	15 fixed speeds plus 1 minimum speed, parameterizable (in the default setting, 3 fixed setpoints plus 1 minimum speed are selectable using terminal block/PROFIBUS)			
Skipped speed ranges	4, programmable			
Setpoint resolution	0.001 rpm digital 12 bit analog			
Braking operation	By means of additional Braking Modules and braking resistors			
Mechanical data				
Degree of protection	IP00 or IP20 dependent on type			
Protection class	I acc. to EN 61800-5-1			
Touch protection	EN 50274 / BGV A3			
Type of cooling	Forced air cooling AF acc. to EN 60146			
Ambient conditions	Storage	Transport	Operation	
Ambient temperature	-25 ... +55 °C	-25 ... +70 °C from <u>-40 °C</u> for 24 hours	<u>0 ... +40 °C</u> up to +55 °C see derating data	
Relative humidity (condensation not permissible)	<u>5 ... 95 %</u> Class 1K4 acc. to EN 60721-3-1	5 ... 95 % at 40 °C Class 2K3 acc. to EN 60721-3-2	<u>5 ... 95 %</u> Class 3K3 acc. to EN 60721-3-3	
Environmental class/harmful chemical substances	Class 1C2 acc. to EN 60721-3-1	Class 2C2 acc. to EN 60721-3-2	Class 3C2 acc. to EN 60721-3-3	
Organic/biological influences	Class 1B1 acc. to EN 60721-3-1	Class 2B1 acc. to EN 60721-3-2	Class 3B1 acc. to EN 60721-3-3	
Pollution degree	2 acc. to EN 61800-5-1			
Installation altitude	Up to 2000 m above sea level without derating, > 2000 m, see derating data			
Mechanical stability	Storage	Transport	Operation	
Vibratory load				
	- Deflection	1.5 mm at <u>5 ... 9 Hz</u>	3.1 mm at <u>5 ... 9 Hz</u>	0.075 mm at 10 ... 58 Hz
	- Acceleration	5 m/s ² at >9 ... 200 Hz Class 1M2 in acc. with EN 60721-3-1	10 m/s ² at >9 ... 200 Hz Class 2M2 to EN 60721-3-2	10 m/s ² at >58 ... 200 Hz -
Shock load				
	- Acceleration	40 m/s ² at 22 ms Class 1M2 in acc. with EN 60721-3-1	100 m/s ² at 11 ms Class 2M2 to EN 60721-3-2	100 m/s ² at 11 ms Class 3M4 to EN 60721-3-3
Compliance with standards				
CE Label	Acc. to EMC Directive No. 2004/108/EC and Low-Voltage Directive No. 2006/95/EC			
Radio interference suppression	The SINAMICS G130 converter systems are not designed for connection to the public power network ("first environment"). RFI suppression is compliant with the EMC product standard for variable-speed drives EN 61800-3, "Second environment" (industrial networks). The equipment can cause electromagnetic interference when it is connected to the public network. However, if supplementary measures are taken (e.g. → line filter), it can also be operated in the "first environment". ¹⁾			
Approvals	cULus			

Deviations from the specified classes are underlined.¹⁾ Applies to cable lengths < 100 m.

Characteristic curves

Derating data

SINAMICS G130 chassis units and the associated system components are rated for an ambient temperature of 40 °C and installation altitudes up to 2000 m above sea level.

For ambient temperatures > 40 °C the output current must be reduced. Ambient temperatures above 55 °C are not permissible.

At installation altitudes > 2000 m above sea level, it should be taken into consideration that with increasing height, the air pressure decreases and therefore the air density. As a consequence, the cooling efficiency and the insulation capacity of the air also decrease.

Due to the reduced cooling efficiency, it is necessary, on one hand, to reduce the ambient temperature and on the other hand, to lower heat loss in the chassis unit by reducing the output current, whereby ambient temperatures lower than 40 °C may be offset to compensate.

The following table specifies the permissible output current as a function of the installation altitude and ambient temperature (the permissible compensation between installation altitude and the ambient temperatures < 40 °C – air intake temperature at the entry to the chassis unit – has been taken into account in the specified values).

The values apply under the precondition that a cooling air flow through the units is guaranteed as stated in the technical data.

As additional measure for installation altitudes from 2000 m up to 5000 m, an isolating transformer is required in order to reduce transient overvoltages according to EN 60664-1. The SINAMICS Low Voltage Engineering Manual contains additional information on this topic and is available as a PDF file on the CD-ROM included with the catalog.

Installation altitude above sea level m	Current derating factor (as a % of the rated current) at an ambient ambient/intake air temperature of							
	20 °C	25 °C	30 °C	35 °C	40 °C	45 °C	50 °C	55 °C
0 ... 2000						93.3 %	86.7 %	80 %
2001 ... 2500					96.3 %			
2501 ... 3000		100 %		98.7 %				
3001 ... 3500								
3501 ... 4000			96.3 %					
4001 ... 4500		97.5 %						
4501 ... 5000	98.2 %							

Current-derating factors for chassis units as a function of the ambient/intake air temperature and the installation altitude.

SINAMICS G130

Drive converter chassis units

75 kW to 800 kW

Characteristic curves (continued)Current derating as a function of pulse frequency

To reduce motor noise or to increase output frequency, the pulse frequency can be increased relative to the factory setting. When the pulse frequency is increased, the derating factor of the output current must be taken into account. This derating factor must be applied to the currents specified in the technical data.

The SINAMICS Low Voltage Engineering Manual contains additional information and is available as a PDF file on the CD-ROM included with Catalog D 11.

Order No.	Type rating	Output current at 2 kHz A	Derating factor at pulse frequency	
	kW		2.5 kHz	4 kHz
380 ... 480 V 3 AC				
6SL3310-1GE32-1AA3	110	210	95 %	82 %
6SL3310-1GE32-6AA3	132	260	95 %	83 %
6SL3310-1GE33-1AA3	160	310	97 %	88 %
6SL3310-1GE33-8AA3	200	380	96 %	87 %
6SL3310-1GE35-0AA3	250	490	94 %	78 %

Derating factor of the output current as a function of the pulse frequency for units with a rated pulse frequency of 2 kHz

Order No.	Type rating	Output current at 1.25 kHz A	Derating factor at pulse frequency		
	kW		2.0 kHz	2.5 kHz	4 kHz
380 ... 480 V 3 AC					
6SL3310-1GE36-1AA3	315	605	83 %	72 %	64 %
6SL3310-1GE37-5AA3	400	745	83 %	72 %	64 %
6SL3310-1GE38-4AA3	450	840	87 %	79 %	64 %
6SL3310-1GE41-0AA3	560	985	92 %	87 %	70 %
500 ... 600 V 3 AC					
6SL3310-1GF31-8AA3	110	175	92 %	87 %	70 %
6SL3310-1GF32-2AA3	132	215	92 %	87 %	70 %
6SL3310-1GF32-6AA3	160	260	92 %	88 %	71 %
6SL3310-1GF33-3AA3	200	330	89 %	82 %	65 %
6SL3310-1GF34-1AA3	250	410	89 %	82 %	65 %
6SL3310-1GF34-7AA3	315	465	92 %	87 %	67 %
6SL3310-1GF35-8AA3	400	575	91 %	85 %	64 %
6SL3310-1GF37-4AA3	500	735	87 %	79 %	64 %
6SL3310-1GF38-1AA3	560	810	83 %	72 %	61 %
660 ... 690 V 3 AC					
6SL3310-1GH28-5AA3	75	85	93 %	89 %	71 %
6SL3310-1GH31-0AA3	90	100	92 %	88 %	71 %
6SL3310-1GH31-2AA3	110	120	92 %	88 %	71 %
6SL3310-1GH31-5AA3	132	150	90 %	84 %	66 %
6SL3310-1GH31-8AA3	160	175	92 %	87 %	70 %
6SL3310-1GH32-2AA3	200	215	92 %	87 %	70 %
6SL3310-1GH32-6AA3	250	260	92 %	88 %	71 %
6SL3310-1GH33-3AA3	315	330	89 %	82 %	65 %
6SL3310-1GH34-1AA3	400	410	89 %	82 %	65 %
6SL3310-1GH34-7AA3	450	465	92 %	87 %	67 %
6SL3310-1GH35-8AA3	560	575	91 %	85 %	64 %
6SL3310-1GH37-4AA3	710	735	87 %	79 %	64 %
6SL3310-1GH38-1AA3	800	810	83 %	72 %	61 %

Derating factor of the output current as a function of the pulse frequency for units with a rated pulse frequency of 1.25 kHz

Characteristic curves (continued)

Overload capability

SINAMICS G130 drive converter chassis units are equipped with an overload reserve to deal with breakaway torques, for example. If larger surge loads occur, this must be taken into account when configuring. In the case of drives with overload requirements, the appropriate base load current must, therefore, be used as a basis for the required load.

The criterion for overload is that the drive is operated with its base-load current before and after the overload occurs on the basis of a duty cycle duration of 300 s.

The base load current I_L for a small overload is based on a duty cycle of 110 % for 60 s or 150 % for 10 s.

The base load current for a high overload I_H is based on a duty cycle of 150 % for 60 s or 160 % for 10 s.

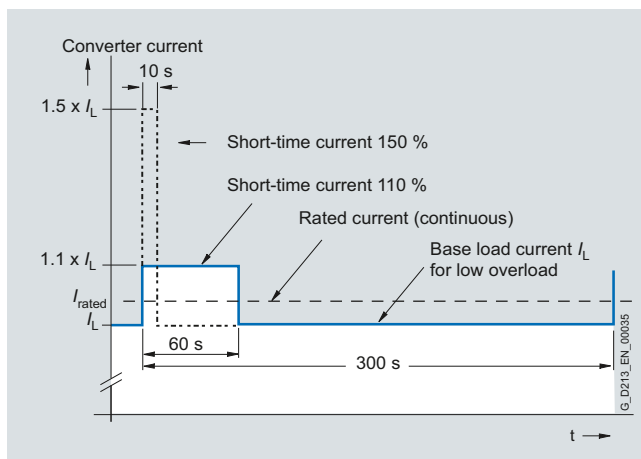

Low overload

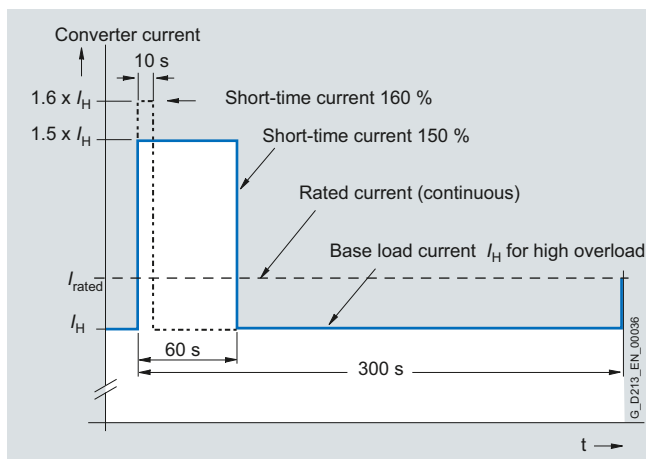

High overload

SINAMICS G130

Drive converter chassis units

Power Modules

Overview



The Power Module contains

- the line-side 6-pulse rectifier
- the capacitors for the voltage-source DC link
- the IGBT-based inverter
- the associated gating and monitoring electronics
- the precharging circuit for the DC link
- the control and power supply for the fans in the Power Module.

Design

The Power Module features the following interfaces as standard:

- Connecting lugs for the line supply
- Connecting lugs for the motor feeder
- Connecting lugs for the Braking Module
- Connecting lugs for dv/dt filters plus VPL
- Connecting lugs for dv/dt filters compact plus VPL
- Connection for external 24 V supply
- 3 DRIVE-CLiQ sockets
- 24 V voltage outputs (max. 2.5 A) for the supply of the
 - CU320-2 Control Unit (control module), of the
 - AOP30 operator panel
 - additional DRIVE-CLiQ components
- 1 temperature sensor input (KTY84-130, PTC or PT100)
- PE/protective conductor connection

Selection and ordering data

Type rating		Rated output current A	Power Module Order No.
at 400 V, 500 V or 690 V	at 60 Hz/ 460 V or 575 V		
kW	hp		
380 ... 480 V 3 AC			
110	150	210	6SL3310-1GE32-1AA3
132	200	260	6SL3310-1GE32-6AA3
160	250	310	6SL3310-1GE33-1AA3
200	300	380	6SL3310-1GE33-8AA3
250	400	490	6SL3310-1GE35-0AA3
315	500	605	6SL3310-1GE36-1AA3
400	600	745	6SL3310-1GE37-5AA3
450	700	840	6SL3310-1GE38-4AA3
560	800	985	6SL3310-1GE41-0AA3
500 ... 600 V 3 AC			
110	150	175	6SL3310-1GF31-8AA3
132	200	215	6SL3310-1GF32-2AA3
160	250	260	6SL3310-1GF32-6AA3
200	300	330	6SL3310-1GF33-3AA3
250	400	410	6SL3310-1GF34-1AA3
315	450	465	6SL3310-1GF34-7AA3
400	600	575	6SL3310-1GF35-8AA3
500	700	735	6SL3310-1GF37-4AA3
560	800	810	6SL3310-1GF38-1AA3
660 ... 690 V 3 AC			
75		85	6SL3310-1GH28-5AA3
90		100	6SL3310-1GH31-0AA3
110		120	6SL3310-1GH31-2AA3
132		150	6SL3310-1GH31-5AA3
160		175	6SL3310-1GH31-8AA3
200		215	6SL3310-1GH32-2AA3
250		260	6SL3310-1GH32-6AA3
315		330	6SL3310-1GH33-3AA3
400		410	6SL3310-1GH34-1AA3
450		465	6SL3310-1GH34-7AA3
560		575	6SL3310-1GH35-8AA3
710		735	6SL3310-1GH37-4AA3
800		810	6SL3310-1GH38-1AA3

Note: The power data in hp units are based on the NEC/CEC standards for the North American market.

Integration

The Power Module communicates with the CU320-2 Control Unit via DRIVE-CLiQ (a fast serial interface) and receives its control information via this route. The DRIVE-CLiQ cable required for this is included in the scope of delivery of the Power Module.

DRIVE-CLiQ cables for establishing connections with other DRIVE-CLiQ devices can be ordered pre-assembled and cut to length as required (→ Signal cables).

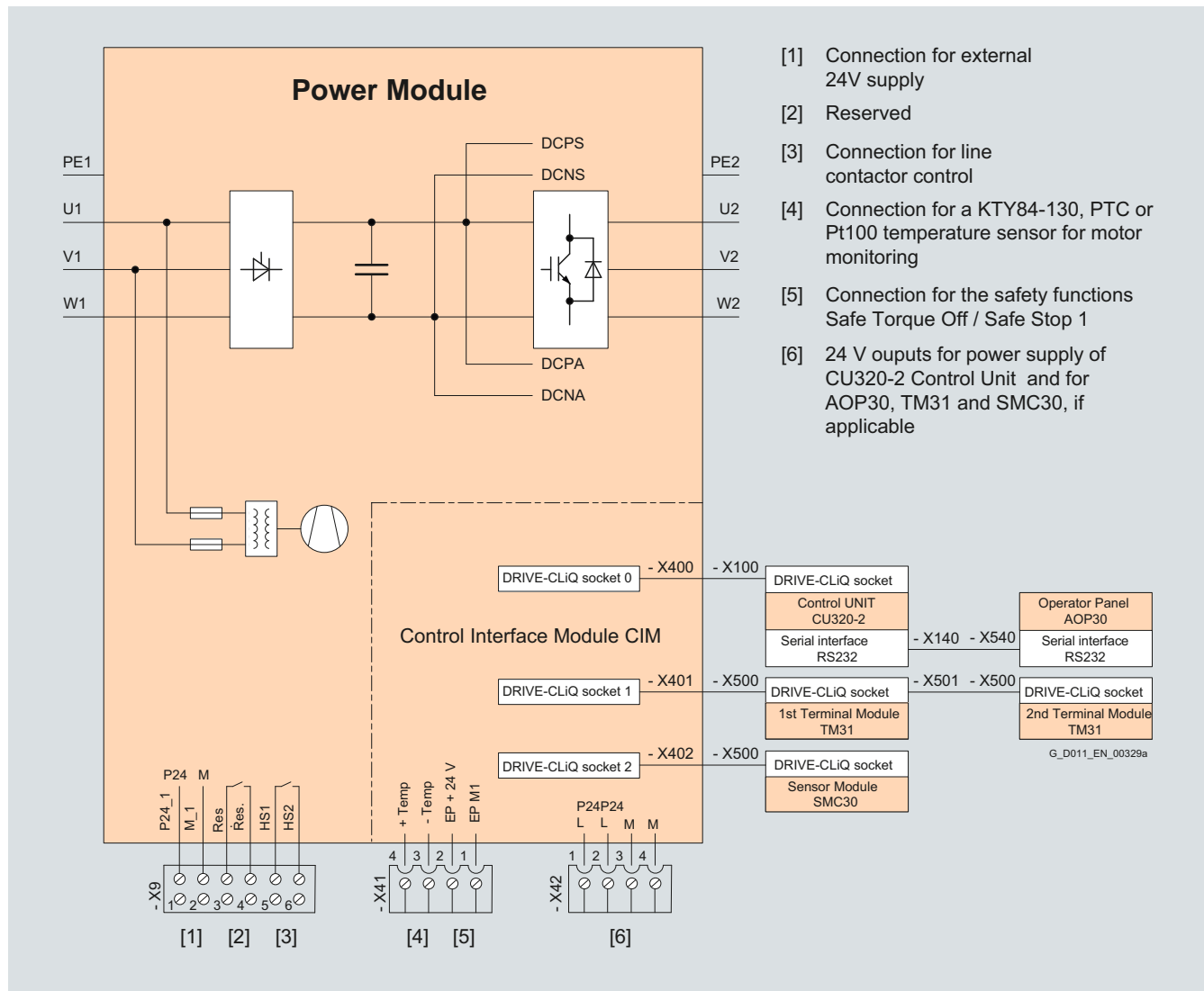

Connection diagram for Power Module

SINAMICS G130

Drive converter chassis units

Power Modules

Technical data

Line voltage 380 ... 480 V 3 AC	Power Modules					
	6SL3310-1GE32-1AA3	6SL3310-1GE32-6AA3	6SL3310-1GE33-1AA3	6SL3310-1GE33-8AA3	6SL3310-1GE35-0AA3	
Type rating						
• at I_L at 50 Hz 400 V ¹⁾	kW	110	132	160	200	250
• at I_H at 50 Hz 400 V ¹⁾	kW	90	110	132	160	200
• at I_L at 60 Hz 460 V ²⁾	hp	150	200	250	300	400
• at I_H at 60 Hz 460 V ²⁾	hp	150	200	200	250	350
Output current						
• Rated current I_{rated}	A	210	260	310	380	490
• Base load current I_L ³⁾	A	205	250	302	370	477
• Base load current I_H ⁴⁾	A	178	233	277	340	438
Input current						
• Rated input current	A	229	284	338	395	509
• Input current, max.	A	335	410	495	606	781
• Current requirement, 24 V DC auxiliary power supply ⁵⁾	A	0.8	0.8	0.9	0.9	0.9
Power loss	kW	2.46	3.27	4.00	4.54	5.78
Cooling-air demand	m ³ /s	0.17	0.23	0.36	0.36	0.36
Cable length, max. between Power Module and motor ⁶⁾						
• shielded	m	300	300	300	300	300
• unshielded	m	450	450	450	450	450
Degree of protection						
		IP20	IP20	IP20	IP20	IP20
Sound pressure level L_{pA} (1 m) at 50/60 Hz						
	dB	64/67	64/67	69/73	69/73	69/73
Line connection U1, V1, W1						
		M10 screw	M10 screw	M10 screw	M10 screw	M10 screw
Conductor cross section, max. (IEC)	mm ²	2 × 185	2 × 185	2 × 240	2 × 240	2 × 240
Motor connection U2/T1, V2/T2, W2/T3						
		M10 screw	M10 screw	M10 screw	M10 screw	M10 screw
Conductor cross section, max. (IEC)	mm ²	2 × 185	2 × 185	2 × 240	2 × 240	2 × 240
PE1/GND connection						
		M10 screw	M10 screw	M10 screw	M10 screw	M10 screw
Conductor cross section, max. (IEC)	mm ²	2 × 185	2 × 185	2 × 240	2 × 240	2 × 240
PE2/GND connection						
		M10 screw	M10 screw	M10 screw	M10 screw	M10 screw
Conductor cross section, max. (IEC)	mm ²	2 × 185	2 × 185	2 × 240	2 × 240	2 × 240
Dimensions						
• Width	mm	326	326	326	326	326
• Height	mm	1400	1400	1533	1533	1533
• Depth	mm	356	356	545	545	545
Weight, approx.	kg	104	104	176	176	176
Conformity		CE	CE	CE	CE	CE
Approvals, acc. to		cULus	cULus	cULus	cULus	cULus
Frame size		FX	FX	GX	GX	GX

Note: The power data in hp units are based on the NEC/CEC standards for the North American market.

¹⁾ Rated power of a typ. 6-pole standard induction motor based on I_L or I_H with 400 V 3 AC 50 Hz.

²⁾ Rated power of a typ. 6-pole standard induction motor based on I_L or I_H with 460 V 3 AC 60 Hz.

³⁾ The base load current I_L is based on a duty cycle of 110 % for 60 s or 150 % for 10 s with a duty cycle duration of 300 s. See technical data (→ Overload capability).

⁴⁾ The base load current I_H is based on a duty cycle of 150 % for 60 s or 160 % for 10 s with a duty cycle duration of 300 s. See technical data (→ Overload capability).

⁵⁾ If the auxiliary supply is to be fed in separately from the load supply, e.g. if the control should be able to continue communication if the line voltage fails.

⁶⁾ Longer cable lengths for specific configurations are available on request.

Technical data (continued)

Line voltage 380 ... 480 V 3 AC		Power Modules			
		6SL3310- 1GE36-1AA3	6SL3310- 1GE37-5AA3	6SL3310- 1GE38-4AA3	6SL3310- 1GE41-0AA3
Type rating					
• at I_L at 50 Hz 400 V ¹⁾	kW	315	400	450	560
• at I_H at 50 Hz 400 V ¹⁾	kW	250	315	400	450
• at I_L at 60 Hz 460 V ²⁾	hp	500	600	700	800
• at I_H at 60 Hz 460 V ²⁾	hp	350	450	600	700
Output current					
• Rated current I_{rated}	A	605	745	840	985
• Base load current $I_L^{3)}$	A	590	725	820	960
• Base load current $I_H^{4)}$	A	460	570	700	860
Input current					
• Rated input current	A	629	775	873	1024
• Input current, max.	A	967	1188	1344	1573
• Current requirement, 24 V DC auxiliary power supply ⁵⁾	A	1.0	1.0	1.0	1.25
Power loss	kW	7.8	9.1	9.6	13.8
Cooling-air demand	m ³ /s	0.78	0.78	0.78	1.48
Cable length, max. between Power Module and motor ⁶⁾					
• shielded	m	300	300	300	300
• unshielded	m	450	450	450	450
Degree of protection					
		IP00	IP00	IP00	IP00
Sound pressure level L_{pA} (1 m) at 50/60 Hz					
	dB	70/73	70/73	70/73	72/75
Line connection U1, V1, W1					
		M12 screw	M12 screw	M12 screw	M12 screw
Conductor cross section, max. (IEC)	mm ²	4 × 240	4 × 240	4 × 240	6 × 240
Motor connection U2/T1, V2/T2, W2/T3					
		M12 screw	M12 screw	M12 screw	M12 screw
Conductor cross section, max. (IEC)	mm ²	4 × 240	4 × 240	4 × 240	6 × 240
PE1/GND connection					
		M12 screw	M12 screw	M12 screw	M12 screw
Conductor cross section, max. (IEC)	mm ²	2 × 240	2 × 240	2 × 240	4 × 240
PE2/GND connection					
		2 × M12 screws	2 × M12 screws	2 × M12 screws	3 × M12 screws
Conductor cross section, max. (IEC)	mm ²	4 × 240	4 × 240	4 × 240	6 × 240
Dimensions					
• Width	mm	503	503	503	909
• Height	mm	1506	1506	1506	1510
• Depth	mm	540	540	540	540
Weight, approx.	kg	294	294	294	530
Conformity					
		CE	CE	CE	CE
Approvals, acc. to					
		cULus	cULus	cULus	cULus
Frame size					
		HX	HX	HX	JX

Note: The power data in hp units are based on the NEC/CEC standards for the North American market.

1) Rated power of a typ. 6-pole standard induction motor based on I_L or I_H with 400 V 3 AC 50 Hz.

2) Rated power of a typ. 6-pole standard induction motor based on I_L or I_H with 460 V 3 AC 60 Hz.

3) The base load current I_L is based on a duty cycle of 110 % for 60 s or 150 % for 10 s with a duty cycle duration of 300 s. See technical data (→ Overload capability).

4) The base load current I_H is based on a duty cycle of 150 % for 60 s or 160 % for 10 s with a duty cycle duration of 300 s. See technical data (→ Overload capability).

5) If the auxiliary supply is to be fed in separately from the load supply, e.g. if the control should be able to continue communication if the line voltage fails.

6) Longer cable lengths for specific configurations are available on request.

SINAMICS G130

Drive converter chassis units

Power Modules

Technical data (continued)

Line voltage 500 ... 600 V 3 AC	Power Modules					
	6SL3310-1GF31-8AA3	6SL3310-1GF32-2AA3	6SL3310-1GF32-6AA3	6SL3310-1GF33-3AA3	6SL3310-1GF34-1AA3	
Type rating						
• at I_L at 50 Hz 500 V ¹⁾	kW	110	132	160	200	250
• at I_H at 50 Hz 500 V ¹⁾	kW	90	110	132	160	200
• at I_L at 60 Hz 575 V ²⁾	hp	150	200	250	300	400
• at I_H at 60 Hz 575 V ²⁾	hp	150	200	200	250	350
Output current						
• Rated current I_{rated}	A	175	215	260	330	410
• Base load current I_L ³⁾	A	171	208	250	320	400
• Base load current I_H ⁴⁾	A	157	192	233	280	367
Input current						
• Rated input current	A	191	224	270	343	426
• Input current, max.	A	279	341	410	525	655
• Current requirement, 24 V DC auxiliary power supply ⁵⁾	A	0.9	0.9	0.9	0.9	1.0
Power loss	kW	3	3.4	3.9	4.9	6.4
Cooling-air demand	m ³ /s	0.36	0.36	0.36	0.36	0.78
Cable length, max. between Power Module and motor ⁶⁾						
• shielded	m	300	300	300	300	300
• unshielded	m	450	450	450	450	450
Degree of protection		IP20	IP20	IP20	IP20	IP00
Sound pressure level L_{pA} (1 m) at 50/60 Hz	dB	69/73	69/73	69/73	69/73	70/73
Line connection U1, V1, W1		M10 screw	M10 screw	M10 screw	M10 screw	M12 screw
Conductor cross section, max. (IEC)	mm ²	2 x 240	2 x 240	2 x 240	2 x 240	4 x 240
Motor connection U2/T1, V2/T2, W2/T3		M10 screw	M10 screw	M10 screw	M10 screw	M12 screw
Conductor cross section, max. (IEC)	mm ²	2 x 240	2 x 240	2 x 240	2 x 240	4 x 240
PE1/GND connection		M10 screw	M10 screw	M10 screw	M10 screw	M12 screw
Conductor cross section, max. (IEC)	mm ²	2 x 240	2 x 240	2 x 240	2 x 240	2 x 240
PE2/GND connection		M10 screw	M10 screw	M10 screw	M10 screw	2 x M12 screws
Conductor cross section, max. (IEC)	mm ²	2 x 240	2 x 240	2 x 240	2 x 240	4 x 240
Dimensions						
• Width	mm	326	326	326	326	503
• Height	mm	1533	1533	1533	1533	1506
• Depth	mm	545	545	545	545	540
Weight, approx.	kg	176	176	176	176	294
Conformity		CE	CE	CE	CE	CE
Approvals, acc. to		cULus	cULus	cULus	cULus	cULus
Frame size		GX	GX	GX	GX	HX

Note: The power data in hp units are based on the NEC/CEC standards for the North American market.

¹⁾ Rated power of a typ. 6-pole standard induction motor based on I_L or I_H with 500 V 3 AC 50 Hz.

²⁾ Rated power of a typ. 6-pole standard induction motor based on I_L or I_H with 575 V 3 AC 60 Hz.

³⁾ The base load current I_L is based on a duty cycle of 110 % for 60 s or 150 % for 10 s with a duty cycle duration of 300 s. See technical data (→ Overload capability).

⁴⁾ The base load current I_H is based on a duty cycle of 150 % for 60 s or 160 % for 10 s with a duty cycle duration of 300 s. See technical data (→ Overload capability).

⁵⁾ If the auxiliary supply is to be fed in separately from the load supply, e.g. if the control should be able to continue communication if the line voltage fails.

⁶⁾ Longer cable lengths for specific configurations are available on request.

Technical data (continued)

Line voltage 500 ... 600 V 3 AC		Power Modules			
		6SL3310- 1GF34-7AA3	6SL3310- 1GF35-8AA3	6SL3310- 1GF37-4AA3	6SL3310- 1GF38-1AA3
Type rating					
• at I_L at 50 Hz 500 V ¹⁾	kW	315	400	500	560
• at I_H at 50 Hz 500 V ¹⁾	kW	250	315	450	500
• at I_L at 60 Hz 575 V ²⁾	hp	450	600	700	800
• at I_H at 60 Hz 575 V ²⁾	hp	450	500	700	700
Output current					
• Rated current I_{rated}	A	465	575	735	810
• Base load current $I_L^{3)}$	A	452	560	710	790
• Base load current $I_H^{4)}$	A	416	514	657	724
Input current					
• Rated input current	A	483	598	764	842
• Input current, max.	A	740	918	1164	1295
• Current requirement, 24 V DC auxiliary power supply ⁵⁾	A	1.0	1.0	1.25	1.25
Power loss	kW	7.3	8.1	12.0	13.3
Cooling-air demand	m ³ /s	0.78	0.78	1.48	1.48
Cable length, max. between Power Module and motor ⁶⁾					
• shielded	m	300	300	300	300
• unshielded	m	450	450	450	450
Degree of protection		IP00	IP00	IP00	IP00
Sound pressure level L_{pA} (1 m) at 50/60 Hz		dB	70/73	73/75	73/75
Line connection U1, V1, W1		M12 screw	M12 screw	M12 screw	M12 screw
Conductor cross section, max. (IEC)	mm ²	4 x 240	4 x 240	6 x 240	6 x 240
Motor connection U2/T1, V2/T2, W2/T3		M12 screw	M12 screw	M12 screw	M12 screw
Conductor cross section, max. (IEC)	mm ²	4 x 240	4 x 240	6 x 240	6 x 240
PE1/GND connection		M12 screw	M12 screw	2 x M12 screws	2 x M12 screws
Conductor cross section, max. (IEC)	mm ²	2 x 240	2 x 240	4 x 240	4 x 240
PE2/GND connection		2 x M12 screws	2 x M12 screws	3 x M12 screws	3 x M12 screws
Conductor cross section, max. (IEC)	mm ²	4 x 240	4 x 240	6 x 240	6 x 240
Dimensions					
• Width	mm	503	503	909	909
• Height	mm	1506	1506	1510	1510
• Depth	mm	540	540	540	540
Weight, approx.	kg	294	294	530	530
Conformity		CE	CE	CE	CE
Approvals, acc. to		cULus	cULus	cULus	cULus
Frame size		HX	HX	JX	JX

Note: The power data in hp units are based on the NEC/CEC standards for the North American market.

1) Rated power of a typ. 6-pole standard induction motor based on I_L or I_H with 500 V 3 AC 50 Hz.

2) Rated power of a typ. 6-pole standard induction motor based on I_L or I_H with 575 V 3 AC 60 Hz.

3) The base load current I_L is based on a duty cycle of 110 % for 60 s or 150 % for 10 s with a duty cycle duration of 300 s. See technical data (→ Overload capability).

4) The base load current I_H is based on a duty cycle of 150 % for 60 s or 160 % for 10 s with a duty cycle duration of 300 s. See technical data (→ Overload capability).

5) If the auxiliary supply is to be fed in separately from the load supply, e.g. if the control should be able to continue communication if the line voltage fails.

6) Longer cable lengths for specific configurations are available on request.

SINAMICS G130

Drive converter chassis units

Power Modules

Technical data (continued)

Line voltage 660 ... 690 V 3 AC		Power Modules					
		6SL3310-1GH28-5AA3	6SL3310-1GH31-0AA3	6SL3310-1GH31-2AA3	6SL3310-1GH31-5AA3	6SL3310-1GH31-8AA3	6SL3310-1GH32-2AA3
Type rating							
• at I_L at 50 Hz 690 V ¹⁾	kW	75	90	110	132	160	200
• at I_H at 50 Hz 690 V ¹⁾	kW	55	75	90	110	132	160
Output current							
• Rated current I_{rated}	A	85	100	120	150	175	215
• Base load current I_L ²⁾	A	80	95	115	142	171	208
• Base load current I_H ³⁾	A	76	89	107	134	157	192
Input current							
• Rated input current	A	93	109	131	164	191	224
• Input current, max.	A	131	155	188	232	279	341
• Current requirement, 24 V DC auxiliary power supply ⁴⁾	A	0.8	0.8	0.8	0.8	0.9	0.9
Power loss	kW	1.5	1.8	2.4	2.5	3.8	4.8
Cooling-air demand	m ³ /s	0.17	0.17	0.17	0.17	0.36	0.36
Cable length, max. between Power Module and motor ⁵⁾							
• shielded	m	300	300	300	300	300	300
• unshielded	m	450	450	450	450	450	450
Degree of protection		IP20	IP20	IP20	IP20	IP20	IP20
Sound pressure level L_{pA} (1 m) at 50/60 Hz	dB	64/67	64/67	64/67	64/67	69/73	69/73
Line connection U1, V1, W1		M10 screw	M10 screw	M10 screw	M10 screw	M10 screw	M10 screw
Conductor cross section, max. (IEC)	mm ²	2 x 185	2 x 185	2 x 185	2 x 185	2 x 240	2 x 240
Motor connection U2/T1, V2/T2, W2/T3		M10 screw	M10 screw	M10 screw	M10 screw	M10 screw	M10 screw
Conductor cross section, max. (IEC)	mm ²	2 x 185	2 x 185	2 x 185	2 x 185	2 x 240	2 x 240
PE1/GND connection		M10 screw	M10 screw	M10 screw	M10 screw	M10 screw	M10 screw
Conductor cross section, max. (IEC)	mm ²	2 x 185	2 x 185	2 x 185	2 x 185	2 x 240	2 x 240
PE2/GND connection		M10 screw	M10 screw	M10 screw	M10 screw	M10 screw	M10 screw
Conductor cross section, max. (IEC)	mm ²	2 x 185	2 x 185	2 x 185	2 x 185	2 x 240	2 x 240
Dimensions							
• Width	mm	326	326	326	326	326	326
• Height	mm	1400	1400	1400	1400	1533	1533
• Depth	mm	356	356	356	356	545	545
Weight, approx.	kg	104	104	104	104	176	176
Conformity		CE	CE	CE	CE	CE	CE
Approvals, acc. to		-	-	-	-	-	-
Frame size		FX	FX	FX	FX	GX	GX

Note: The power data in hp units are based on the NEC/CEC standards for the North American market.

¹⁾ Rated power of a typ. 6-pole standard induction motor based on I_L or I_H with 690 V 3 AC 50 Hz.

²⁾ The base load current I_L is based on a duty cycle of 110 % for 60 s or 150 % for 10 s with a duty cycle duration of 300 s.

³⁾ The base load current I_H is based on a duty cycle of 150 % for 60 s or 160 % for 10 s with a duty cycle duration of 300 s. See technical data (→ Overload capability).

⁴⁾ If the auxiliary supply is to be fed in separately from the load supply, e.g. if the control should be able to continue communication if the line voltage fails.

⁵⁾ Longer cable lengths for specific configurations are available on request.

Technical data (continued)

Line voltage 660 ... 690 V 3 AC	Power Modules							
	6SL3310-1GH32-6AA3	6SL3310-1GH33-3AA3	6SL3310-1GH34-1AA3	6SL3310-1GH34-7AA3	6SL3310-1GH35-8AA3	6SL3310-1GH37-4AA3	6SL3310-1GH38-1AA3	
Type rating								
• at I_L at 50 Hz 690 V ¹⁾	kW	250	315	400	450	560	710	800
• at I_H at 50 Hz 690 V ¹⁾	kW	200	250	315	400	500	560	710
Output current								
• Rated current I_{rated}	A	260	330	410	465	575	735	810
• Base load current I_L ²⁾	A	250	320	400	452	560	710	790
• Base load current I_H ³⁾	A	233	280	367	416	514	657	724
Input current								
• Rated input current	A	270	343	426	483	598	764	842
• Input current, max.	A	410	525	655	740	918	1164	1295
• Current requirement, 24 V DC auxiliary power supply ⁴⁾	A	0.9	0.9	1.0	1.0	1.0	1.25	1.25
Power loss	kW	5	5.8	7.5	8.5	10.3	12.8	13.9
Cooling-air demand	m ³ /s	0.36	0.36	0.78	0.78	0.78	1.48	1.48
Cable length, max. between Power Module and motor ⁵⁾								
• shielded	m	300	300	300	300	300	300	300
• unshielded	m	450	450	450	450	450	450	450
Degree of protection		IP20	IP20	IP00	IP00	IP00	IP00	IP00
Sound pressure level L_{pA} (1 m) at 50/60 Hz	dB	69/73	69/73	70/73	70/73	70/73	73/75	73/75
Line connection U1, V1, W1		M10 screw	M10 screw	2 x M12 screws	2 x M12 screws	2 x M12 screws	3 x M12 screws	3 x M12 screws
Conductor cross section, max. (IEC)	mm ²	2 x 240	2 x 240	4 x 240	4 x 240	4 x 240	6 x 240	6 x 240
Motor connection U2/T1, V2/T2, W2/T3		M10 screw	M10 screw	2 x M12 screws	2 x M12 screws	2 x M12 screws	3 x M12 screws	3 x M12 screws
Conductor cross section, max. (IEC)	mm ²	2 x 240	2 x 240	4 x 240	4 x 240	4 x 240	6 x 240	6 x 240
PE1/GND connection		M10 screw	M10 screw	M12 screw	M12 screw	M12 screw	2 x M12 screws	2 x M12 screws
Conductor cross section, max. (IEC)	mm ²	2 x 240	2 x 240	2 x 240	2 x 240	2 x 240	4 x 240	4 x 240
PE2/GND connection		M10 screw	M10 screw	2 x M12 screws	2 x M12 screws	2 x M12 screws	3 x M12 screws	3 x M12 screws
Conductor cross section, max. (IEC)	mm ²	2 x 240	2 x 240	4 x 240	4 x 240	4 x 240	6 x 240	6 x 240
Dimensions								
• Width	mm	326	326	503	503	503	909	909
• Height	mm	1533	1533	1506	1506	1506	1510	1510
• Depth	mm	545	545	540	540	540	540	540
Weight, approx.	kg	176	176	294	294	294	530	530
Conformity		CE	CE	CE	CE	CE	CE	CE
Approvals, acc. to		-	-	-	-	-	-	-
Frame size		GX	GX	HX	HX	HX	JX	JX

Note: The power data in hp units are based on the NEC/CEC standards for the North American market.

¹⁾ Rated power of a typ. 6-pole standard induction motor based on I_L or I_H with 690 V 3 AC 50 Hz.

²⁾ The base load current I_L is based on a duty cycle of 110 % for 60 s or 150 % for 10 s with a duty cycle duration of 300 s.

³⁾ The base load current I_H is based on a duty cycle of 150 % for 60 s or 160 % for 10 s with a duty cycle duration of 300 s. See technical data (→ Overload capability).

⁴⁾ If the auxiliary supply is to be fed in separately from the load supply, e.g. if the control should be able to continue communication if the line voltage fails.

⁵⁾ Longer cable lengths for specific configurations are available on request.

SINAMICS G130

Drive converter chassis units

Line-side power components Line filters

Overview

Line-side power components are used to protect the connected components against transient or continuous overvoltages and ensure that prescribed limit values are adhered to.



To limit the emitted interference, the drive converters are equipped as standard with a radio interference suppression filter that conforms to the limits defined in Category C3. SINAMICS G130 converters equipped with the line filter also meet the limits for use in the first environment (Category C2) as specified in EN 61800-3.¹⁾

SINAMICS G130 units comply with the noise immunity requirements defined in this standard for the first and second environments.

In conjunction with line reactors, line filters also limit the conducted interference emitted by the Power Modules to the limit values of Category C2 defined in product standard EN 61800-3. When combined with a plant design rigorously based on the EMC design directives, the limit values at the installation site will conform to the requirements for the first environment.

The line filters are suitable for connection to grounded systems (TN or TT systems with grounded star point).

Selection and ordering data

Suitable for Power Module	Type rating of the Power Module at 400 V, 500 V or 690 V kW	Line filter Order No.
380 ... 480 V 3 AC		
6SL3310-1GE32-1AA3	110	6SL3000-0BE32-5AA0
6SL3310-1GE32-6AA3	132	6SL3000-0BE34-4AA0
6SL3310-1GE33-1AA3	160	
6SL3310-1GE33-8AA3	200	
6SL3310-1GE35-0AA3	250	6SL3000-0BE36-0AA0
6SL3310-1GE36-1AA3	315	6SL3000-0BE41-2AA0
6SL3310-1GE37-5AA3	400	
6SL3310-1GE38-4AA3	450	
6SL3310-1GE41-0AA3	560	
500 ... 600 V 3 AC		
6SL3310-1GF31-8AA3	110	6SL3000-0BG32-5AA0
6SL3310-1GF32-2AA3	132	
6SL3310-1GF32-6AA3	160	6SL3000-0BG34-4AA0
6SL3310-1GF33-3AA3	200	
6SL3310-1GF34-1AA3	250	
6SL3310-1GF34-7AA3	315	6SL3000-0BG36-0AA0
6SL3310-1GF35-8AA3	400	6SL3000-0BG41-2AA0
6SL3310-1GF37-4AA3	500	
6SL3310-1GF38-1AA3	560	
660 ... 690 V 3 AC		
6SL3310-1GH28-5AA3	75	6SL3000-0BG32-5AA0
6SL3310-1GH31-0AA3	90	
6SL3310-1GH31-2AA3	110	
6SL3310-1GH31-5AA3	132	
6SL3310-1GH31-8AA3	160	
6SL3310-1GH32-2AA3	200	
6SL3310-1GH32-6AA3	250	6SL3000-0BG34-4AA0
6SL3310-1GH33-3AA3	315	
6SL3310-1GH34-1AA3	400	
6SL3310-1GH34-7AA3	450	6SL3000-0BG36-0AA0
6SL3310-1GH35-8AA3	560	6SL3000-0BG41-2AA0
6SL3310-1GH37-4AA3	710	
6SL3310-1GH38-1AA3	800	

The SINAMICS Low Voltage Engineering Manual contains additional information on the line filters as well as EMC-compliant plant/system design – and is available as a PDF file on the CD-ROM included with the Catalog D 11.

¹⁾ Applies to cable lengths < 100 m.

SINAMICS G130

Drive converter chassis units

Line-side power components
Line filters

Technical data

Line voltage 380 ... 480 V 3 AC		Line filter			
		6SL3000-0BE32-5AA0	6SL3000-0BE34-4AA0	6SL3000-0BE36-0AA0	6SL3000-0BE41-2AA0
Rated current	A	250	440	600	1200
Power loss	kW	0.049	0.049	0.055	0.137
Line/load connection		1 x hole for M10	1 x hole for M10	1 x hole for M10	1 x hole for M12
Conductor cross section, max. (IEC)	mm ²	Provided for busbar connection	Provided for busbar connection	Provided for busbar connection	Provided for busbar connection
PE connection		Hole for M8	Hole for M8	Hole for M10	Hole for M10
Degree of protection		IP00	IP00	IP00	IP00
Dimensions					
• Width	mm	360	360	400	425
• Height	mm	240	240	265	265
• Depth	mm	116	116	140	145
Weight, approx.	kg	12.3	12.3	19	25.8
Approvals, acc. to		cURus	cURus	cURus	cURus
Suitable for Power Module		6SL3310-1GE32-1AA3 (110 kW)	6SL3310-1GE32-6AA3 (132 kW) 6SL3310-1GE33-1AA3 (160 kW) 6SL3310-1GE33-8AA3 (200 kW)	6SL3310-1GE35-0AA3 (250 kW)	6SL3310-1GE36-1AA3 (315 kW) 6SL3310-1GE37-5AA3 (400 kW) 6SL3310-1GE38-4AA3 (450 kW) 6SL3310-1GE41-0AA3 (560 kW)

Line voltage 500 ... 600 V 3 AC		Line filter			
		6SL3000-0BG32-5AA0	6SL3000-0BG34-4AA0	6SL3000-0BG36-0AA0	6SL3000-0BG41-2AA0
Rated current	A	250	440	600	1200
Power loss	kW	0.049	0.049	0.055	0.137
Line/load connection		1 x hole for M10	1 x hole for M10	1 x hole for M10	1 x hole for M12
Conductor cross section, max. (IEC)	mm ²	Provided for busbar connection	Provided for busbar connection	Provided for busbar connection	Provided for busbar connection
PE connection		Hole for M8	Hole for M8	Hole for M10	Hole for M10
Degree of protection		IP00	IP00	IP00	IP00
Dimensions					
• Width	mm	360	360	400	425
• Height	mm	240	240	265	265
• Depth	mm	116	116	140	145
Weight, approx.	kg	12.3	12.3	19	25.2
Approvals, acc. to		cURus	cURus	cURus	cURus
Suitable for Power Module		6SL3310-1GF31-8AA3 (110 kW) 6SL3310-1GF32-2AA3 (132 kW)	6SL3310-1GF32-6AA3 (160 kW) 6SL3310-1GF33-3AA3 (200 kW) 6SL3310-1GE34-1AA3 (250 kW)	6SL3310-1GF34-7AA3 (315 kW)	6SL3310-1GF35-8AA3 (400 kW) 6SL3310-1GF37-4AA3 (500 kW) 6SL3310-1GF38-1AA3 (560 kW)

SINAMICS G130

Drive converter chassis units

Line-side power components Line filters

Technical data (continued)

Line voltage 660 ... 690 V 3 AC		Line filter			
		6SL3000-0BG32-5AA0	6SL3000-0BG34-4AA0	6SL3000-0BG36-0AA0	6SL3000-0BG41-2AA0
Rated current	A	250	440	600	1200
Power loss	kW	0.049	0.049	0.055	0.137
Line/load connection		1 x hole for M10	1 x hole for M10	1 x hole for M10	1 x hole for M12
Conductor cross section, max. (IEC)	mm ²	Provided for busbar connection	Provided for busbar connection	Provided for busbar connection	Provided for busbar connection
PE connection		Hole for M8	Hole for M8	Hole for M10	Hole for M10
Degree of protection		IP00	IP00	IP00	IP00
Dimensions					
• Width	mm	360	360	400	425
• Height	mm	240	240	265	265
• Depth	mm	116	116	140	145
Weight, approx.	kg	12.3	12.3	19	25.2
Approvals, acc. to		cURus	cURus	cURus	cURus
Suitable for Power Module		6SL3310-1GH28-5AA3 (75 kW) 6SL3310-1GH31-0AA3 (90 kW) 6SL3310-1GH31-2AA3 (110 kW) 6SL3310-1GH31-5AA3 (132 kW) 6SL3310-1GH31-8AA3 (160 kW) 6SL3310-1GH32-2AA3 (200 kW)	6SL3310-1GH32-6AA3 (250 kW)	6SL3310-1GH34-7AA3 (450 kW)	6SL3310-1GH35-8AA3 (560 kW) 6SL3310-1GH37-4AA3 (710 kW) 6SL3310-1GH38-1AA3 (800 kW)

SINAMICS G130

Drive converter chassis units

Line-side power components Line Harmonics Filters

Overview



Line Harmonics Filters reduce the converter's low-frequency harmonic effects to a level that can otherwise only be achieved using 12-pulse rectifiers.

They render the converter compliant with every stringent limit value specified in standard IEEE 519-1992.

Design

Line Harmonics Filters are supplied as stand-alone components in a rugged housing. They are installed between the customer-end low-voltage distribution panel and the converter. The voltage is disconnected and fused in the customer-end low-voltage switchgear, as is the power supply cable.

The Line Harmonics Filters have no fans (natural convection cooling). This means that no external auxiliary power supply is required.

The line harmonics filters are equipped with a floating thermostatic switch, which can be monitored externally, for the purpose of monitoring thermal overloads (as a result of insufficient cooling air being fed in, for example).

Note: The converter must have a line reactor in order to use a Line Harmonics Filter.

Selection and ordering data

Suitable for Power Module	Type rating of the Power Module at 400 V, 500 V or 690 V kW	Line Harmonics Filter Order No.
380 ... 480 V 3 AC		
6SL3310-1GE33-1AA3	160	6SL3000-OJE36-1AA0
6SL3310-1GE33-8AA3	200	
6SL3310-1GE35-0AA3	250	
6SL3310-1GE36-1AA3	315	
6SL3310-1GE37-5AA3	400	6SL3000-OJE38-4AA0
6SL3310-1GE38-4AA3	450	
6SL3310-1GE41-0AA3	560	6SL3000-OJE41-0AA0
500 ... 600 V 3 AC		
6SL3310-1GF31-8AA3	110	6SL3000-OJH33-3AA0
6SL3310-1GF32-2AA3	132	
6SL3310-1GF32-6AA3	160	
6SL3310-1GF33-3AA3	200	
6SL3310-1GF34-1AA3	250	6SL3000-OJH34-7AA0
6SL3310-1GF34-7AA3	315	
6SL3310-1GF35-8AA3	400	6SL3000-OJH35-8AA0
6SL3310-1GF37-4AA3	500	6SL3000-OJH38-1AA0
6SL3310-1GF38-1AA3	560	
660 ... 690 V 3 AC		
6SL3310-1GH31-8AA3	160	6SL3000-OJH33-3AA0
6SL3310-1GH32-2AA3	200	
6SL3310-1GH32-6AA3	250	
6SL3310-1GH33-3AA3	315	
6SL3310-1GH34-1AA3	400	6SL3000-OJH34-7AA0
6SL3310-1GH34-7AA3	450	
6SL3310-1GH35-8AA3	560	6SL3000-OJH35-8AA0
6SL3310-1GH37-4AA3	710	6SL3000-OJH38-1AA0
6SL3310-1GH38-1AA3	800	

The SINAMICS Low Voltage Engineering Manual contains additional information about the line harmonics filters, which is available as a PDF file on the CD-ROM included with the catalog.

SINAMICS G130

Drive converter chassis units

Line-side power components Line Harmonics Filters

Technical data

Line voltage 380 ... 480 V 3 AC		Line Harmonics Filter		
		6SL3000-0JE36-1AA0	6SL3000-0JE38-4AA0	6SL3000-0JE41-0AA0
Rated current ¹⁾	A	500	700	900
Power loss	kW	3.1	4.5	5.6
Line/load connection				
Conductor cross section, max. (IEC)	mm ²	4 × 240	4 × 240	4 × 240
PE connection		3 × M12 stud	3 × M12 stud	3 × M12 stud
Degree of protection		IP21	IP21	IP21
Dimensions				
• Width	mm	600	800	1000
• Height	mm	1700	1700	1700
• Depth	mm	540	540	540
Weight, approx.	kg	460	600	900
Paint finish		RAL 7035	RAL 7035	RAL 7035
Standards		IEEE 519-1992	IEEE 519-1992	IEEE 519-1992
Conformity		CE	CE	CE
Suitable for Power Module		6SL3310-1GE33-1AA3 (160 kW) 6SL3310-1GE33-8AA3 (200 kW) 6SL3310-1GE35-0AA3 (250 kW) 6SL3310-1GE36-1AA3 (315 kW)	6SL3310-1GE37-5AA3 (400 kW) 6SL3310-1GE38-4AA3 (450 kW)	6SL3310-1GE41-0AA3 (560 kW)

Line voltage 500 ... 600 V 3 AC 660 ... 690 V 3 AC		Line Harmonics Filter			
		6SL3000-0JH33-3AA0	6SL3000-0JH34-7AA0	6SL3000-0JH35-8AA0	6SL3000-0JH38-1AA0
Rated current ¹⁾	A	290	400	520	710
Power loss	kW	3.1	4.6	5.7	7.97
Line/load connection					
Conductor cross section, max. (IEC)	mm ²	4 × 240	4 × 240	4 × 240	4 × 240
PE connection		3 × M12 stud	3 × M12 stud	3 × M12 stud	3 × M12 stud
Degree of protection		IP21	IP21	IP21	IP21
Dimensions					
• Width	mm	600	800	1000	1000
• Height	mm	1700	1700	1700	1700
• Depth	mm	540	540	540	540
Weight, approx.	kg	450	600	830	830
Paint finish		RAL 7035	RAL 7035	RAL 7035	RAL 7035
Standards		IEEE 519-1992	IEEE 519-1992	IEEE 519-1992	IEEE 519-1992
Conformity		CE	CE	CE	CE
Suitable for Power Module		6SL3310-1GF31-8AA3 (110 kW) 6SL3310-1GF32-2AA3 (132 kW) 6SL3310-1GF32-6AA3 (160 kW) 6SL3310-1GH31-8AA3 (160 kW) 6SL3310-1GF33-3AA3 (200 kW) 6SL3310-1GH32-2AA3 (200 kW) 6SL3310-1GF32-6AA3 (250 kW) 6SL3310-1GH33-3AA3 (315 kW)	6SL3310-1GF34-1AA3 (250 kW) 6SL3310-1GF34-7AA3 (315 kW) 6SL3310-1GH34-1AA3 (400 kW) 6SL3310-1GH34-7AA3 (450 kW)	6SL3310-1GF35-8AA3 (400 kW) 6SL3310-1GH35-8AA3 (560 kW)	6SL3310-1GF37-4AA3 (500 kW) 6SL3310-1GF38-1AA3 (560 kW) 6SL3310-1GH37-4AA3 (710 kW) 6SL3310-1GH38-1AA3 (800 kW)

¹⁾ The rated current of the Line Harmonics Filters is defined according to the active power. It can therefore be lower than the rated input current of the relevant Power Module.

SINAMICS G130

Drive converter chassis units

Line-side power components

Line reactors

Overview



It is recommended that a line reactor is always connected on the line side of the converter, as in practice, it is often not known on which supply configuration individual converters are to be operated, i.e. which supply short-circuit power is present at the converter connection point.

A line reactor is not only required when the value for RSC is less than the values listed in the above table. This is the case, when the converter, as shown in the following figure, is connected to the line through a transformer with the appropriate rating.

Notice: A line reactor is always needed, however, if a line filter is used.

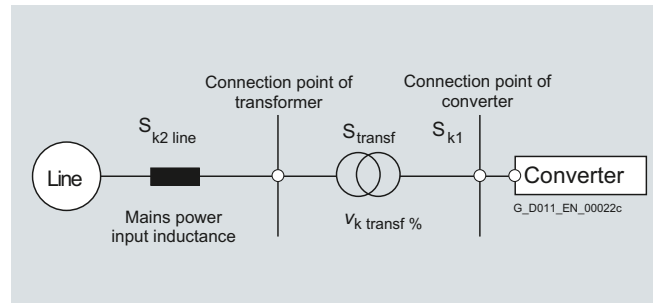

In this case, the line supply short-circuit power S_{k1} at the converter connection point is approximately:

$$S_{k1} = S_{transf} / (V_k transf + S_{transf} / S_{k2 line})$$

A line reactor is needed for high short-circuit power levels, partly to protect the actual converter against excessive harmonic currents, and thus against overload, and partly to limit line harmonics to the permitted values. The harmonic currents are limited by the complete inductance comprising the line reactor and mains supply cable inductance. Line reactors can be omitted if the mains supply cable inductance is increased sufficiently, i.e., the value of RSC must be sufficiently small.

RSC = Relative Short-Circuit power: Ratio of short-circuit power $S_{k Line}$ at the line connection point to fundamental apparent output S_{conv} of the connected converters (to EN 61800-5-1/VDE 0160).

Formula symbol	Meaning
S_{transf}	Transformer power rating
$S_{k transf}$	Relative short-circuit power of the transformer
$S_{k2 line}$	Short-circuit power of the higher-level voltage level
V_k	Relative short-circuit voltage

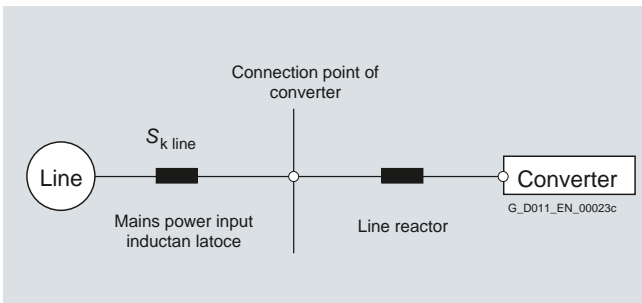

For SINAMICS G130 drive converter chassis units the following applies:

Power	Line reactor can be omitted	Line reactor required
kW	for RSC	for RSC
< 200	≤ 43	> 43
200 ... 500	≤ 33	> 33
> 500	≤ 20	> 20

2

SINAMICS G130

Drive converter chassis units

Line-side power components Line reactors

Selection and ordering data

Suitable for Power Module	Type rating of the Power Module at 400 V, 500 V or 690 V kW	Line reactor Order No.
380 ... 480 V 3 AC		
6SL3310-1GE32-1AA3	110	6SL3000-0CE32-3AA0
6SL3310-1GE32-6AA3	132	6SL3000-0CE32-8AA0
6SL3310-1GE33-1AA3	160	6SL3000-0CE33-3AA0
6SL3310-1GE33-8AA3	200	6SL3000-0CE35-1AA0
6SL3310-1GE35-0AA3	250	
6SL3310-1GE36-1AA3	315	6SL3000-0CE36-3AA0
6SL3310-1GE37-5AA3	400	6SL3000-0CE37-7AA0
6SL3310-1GE38-4AA3	450	6SL3000-0CE38-7AA0
6SL3310-1GE41-0AA3	560	6SL3000-0CE41-0AA0
500 ... 600 V 3 AC		
6SL3310-1GF31-8AA3	110	6SL3000-0CH32-2AA0
6SL3310-1GF32-2AA3	132	
6SL3310-1GF32-6AA3	160	6SL3000-0CH32-7AA0
6SL3310-1GF33-3AA3	200	6SL3000-0CH33-4AA0
6SL3310-1GF34-1AA3	250	6SL3000-0CH34-8AA0
6SL3310-1GF34-7AA3	315	
6SL3310-1GF35-8AA3	400	6SL3000-0CH36-0AA0
6SL3310-1GF37-4AA3	500	6SL3000-0CH38-4AA0
6SL3310-1GF38-1AA3	560	
660 ... 690 V 3 AC		
6SL3310-1GH28-5AA3	75	6SL3000-0CH31-1AA0
6SL3310-1GH31-0AA3	90	
6SL3310-1GH31-2AA3	110	6SL3000-0CH31-6AA0
6SL3310-1GH31-5AA3	132	
6SL3310-1GH31-8AA3	160	6SL3000-0CH32-2AA0
6SL3310-1GH32-2AA3	200	
6SL3310-1GH32-6AA3	250	6SL3000-0CH32-7AA0
6SL3310-1GH33-3AA3	315	6SL3000-0CH33-4AA0
6SL3310-1GH34-1AA3	400	6SL3000-0CH34-8AA0
6SL3310-1GH34-7AA3	450	
6SL3310-1GH35-8AA3	560	6SL3000-0CH36-0AA0
6SL3310-1GH37-4AA3	710	6SL3000-0CH38-4AA0
6SL3310-1GH38-1AA3	800	

SINAMICS G130

Drive converter chassis units

Line-side power components
Line reactors

Technical data

Line voltage 380 ... 480 V 3 AC		Line reactor			
		6SL3000-0CE32-3AA0	6SL3000-0CE32-8AA0	6SL3000-0CE33-3AA0	6SL3000-0CE35-1AA0
I_{thmax}	A	224	278	331	508
Nominal inductance L_{rated}	μ H	76	62	52	42
Power loss	kW	0.274	0.247	0.267	0.365
Line/load connection		1 × hole for M10	1 × hole for M10	1 × hole for M10	1 × hole for M12
Conductor cross section, max. (IEC)	mm ²	Provided for busbar connection	Provided for busbar connection	Provided for busbar connection	Provided for busbar connection
PE connection		M6 screw	M6 screw	M6 screw	M6 screw
Degree of protection		IP00	IP00	IP00	IP00
Dimensions					
• Width	mm	270	270	270	300
• Height	mm	248	248	248	269
• Depth	mm	200	200	200	212
Weight, approx.	kg	24.5	26.0	27.8	38
Conformity		CE	CE	CE	CE
Approvals, acc. to		cURus	cURus	cURus	cURus
Suitable for Power Module		6SL3310-1GE32-1AA3 (110 kW)	6SL3310-1GE32-6AA3 (132 kW)	6SL3310-1GE33-1AA3 (160 kW)	6SL3310-1GE33-8AA3 (200 kW) 6SL3310-1GE35-0AA3 (250 kW)

Line voltage 380 ... 480 V 3 AC		Line reactor			
		6SL3000-0CE36-3AA0	6SL3000-0CE37-7AA0	6SL3000-0CE38-7AA0	6SL3000-0CE41-0AA0
I_{thmax}	A	628	773	871	1022
Nominal inductance L_{rated}	μ H	27	22	19	16
Power loss	kW	0.368	0.351	0.458	0.498
Line/load connection		1 × hole for M12	1 × hole for M12	1 × hole for M12	1 × hole for M12
Conductor cross section, max. (IEC)	mm ²	Provided for busbar connection	Provided for busbar connection	Provided for busbar connection	Provided for busbar connection
PE connection		M6 screw	M6 screw	M6 screw	M6 screw
Degree of protection		IP00	IP00	IP00	IP00
Dimensions					
• Width	mm	300	300	350	350
• Height	mm	269	269	321	321
• Depth	mm	212	212	212	212
Weight, approx.	kg	41.4	51.3	63.2	69.6
Conformity		CE	CE	CE	CE
Approvals, acc. to		cURus	cURus	cURus	cURus
Suitable for Power Module		6SL3310-1GE36-1AA3 (315 kW)	6SL3310-1GE37-5AA3 (400 kW)	6SL3310-1GE38-4AA3 (450 kW)	6SL3310-1GE41-0AA3 (560 kW)

SINAMICS G130

Drive converter chassis units

Line-side power components Line reactors

Technical data (continued)

Line voltage 500 ... 600 V 3 AC		Line reactor			
		6SL3000-0CH32-2AA0	6SL3000-0CH32-2AA0	6SL3000-0CH32-7AA0	6SL3000-0CH33-4AA0
I_{thmax}	A	260	215	270	342
Nominal inductance L_{rated}	μ H	150	150	100	81
Power loss	kW	0.24	0.275	0.277	0.27
Line/load connection		1 × hole for M10	1 × hole for M10	1 × hole for M10	1 × hole for M10
Conductor cross section, max. (IEC)	mm ²	Provided for busbar connection	Provided for busbar connection	Provided for busbar connection	Provided for busbar connection
PE connection		M6 screw	M6 screw	M6 screw	M6 screw
Degree of protection		IP00	IP00	IP00	IP00
Dimensions					
• Width	mm	270	270	270	270
• Height	mm	248	248	248	248
• Depth	mm	200	200	200	200
Weight, approx.	kg	31.1	31.1	27.9	38.9
Conformity		CE	CE	CE	CE
Approvals, acc. to		cURus	cURus	cURus	cURus
Suitable for Power Module		6SL3310-1GF31-8AA3 (110 kW)	6SL3310-1GF32-2AA3 (132 kW)	6SL3310-1GF32-6AA3 (160 kW)	6SL3310-1GF33-3AA3 (200 kW)

Line voltage 500 ... 600 V 3 AC		Line reactor		
		6SL3000-0CH34-8AA0	6SL3000-0CH36-0AA0	6SL3000-0CH38-4AA0
I_{thmax}	A	482	597	840
Nominal inductance L_{rated}	μ H	65	46	40
Power loss	kW	0.48	0.485	0.618
Line/load connection		1 × hole for M10	1 × hole for M12	1 × hole for M12
Conductor cross section, max. (IEC)	mm ²	Provided for busbar connection	Provided for busbar connection	Provided for busbar connection
PE connection		M6 screw	M6 screw	M6 screw
Degree of protection		IP00	IP00	IP00
Dimensions				
• Width	mm	350	350	410
• Height	mm	321	321	385
• Depth	mm	232	232	224
Weight, approx.	kg	55.6	63.8	98
Conformity		CE	CE	CE
Approvals, acc. to		cURus	cURus	cURus
Suitable for Power Module		6SL3310-1GF34-1AA3 (250 kW) 6SL3310-1GF34-7AA3 (315 kW)	6SL3310-1GF35-8AA3 (400 kW)	6SL3310-1GF37-4AA3 (500 kW) 6SL3310-1GF38-1AA3 (560 kW)

SINAMICS G130

Drive converter chassis units

Line-side power components
Line reactors

Technical data (continued)

Line voltage 660 ... 690 V 3 AC		Line reactor			
		6SL3000-0CH31-1AA0	6SL3000-0CH31-6AA0	6SL3000-0CH32-2AA0	6SL3000-0CH32-7AA0
I_{thmax}	A	107	155	230	270
Nominal inductance L_{rated}	μ H	310	220	150	100
Power loss	kW	0.252	0.279	0.275	0.277
Line/load connection		1 × hole for M10	1 × hole for M10	1 × hole for M10	1 × hole for M10
Conductor cross section, max. (IEC)	mm ²	Provided for busbar connection	Provided for busbar connection	Provided for busbar connection	Provided for busbar connection
PE connection		M6 screw	M6 screw	M6 screw	M6 screw
Degree of protection		IP00	IP00	IP00	IP00
Dimensions					
• Width	mm	270	270	270	270
• Height	mm	248	248	248	248
• Depth	mm	200	200	200	200
Weight, approx.	kg	24.4	25.9	31.1	27.9
Conformity		CE	CE	CE	CE
Approvals, acc. to		cURus	cURus	cURus	cURus
Suitable for Power Module		6SL3310-1GH28-5AA3 (75 kW) 6SL3310-1GH31-0AA3 (90 kW)	6SL3310-1GH31-2AA3 (110 kW) 6SL3310-1GH31-5AA3 (132 kW)	6SL3310-1GH31-8AA3 (160 kW) 6SL3310-1GH32-2AA3 (200 kW)	6SL3310-1GH32-6AA3 (250 kW)

Line voltage 660 ... 690 V 3 AC		Line reactor			
		6SL3000-0CH33-4AA0	6SL3000-0CH34-8AA0	6SL3000-0CH36-0AA0	6SL3000-0CH38-4AA0
I_{thmax}	A	342	482	597	840
Nominal inductance L_{rated}	μ H	81	65	46	40
Power loss	kW	0.27	0.48	0.485	0.618
Line/load connection		1 × hole for M10	1 × hole for M10	1 × hole for M12	1 × hole for M12
Conductor cross section, max. (IEC)	mm ²	Provided for busbar connection	Provided for busbar connection	Provided for busbar connection	Provided for busbar connection
PE connection		M6 screw	M6 screw	M6 screw	M6 screw
Degree of protection		IP00	IP00	IP00	IP00
Dimensions					
• Width	mm	270	350	350	410
• Height	mm	248	321	321	385
• Depth	mm	200	232	232	224
Weight, approx.	kg	38.9	55.6	63.8	98
Conformity		CE	CE	CE	CE
Approvals, acc. to		cURus	cURus	cURus	cURus
Suitable for Power Module		6SL3310-1GH33-3AA3 (315 kW)	6SL3310-1GH34-1AA3 (400 kW) 6SL3310-1GH34-7AA3 (450 kW)	6SL3310-1GH35-8AA3 (560 kW)	6SL3310-1GH37-4AA3 (710 kW) 6SL3310-1GH38-1AA3 (800 kW)

SINAMICS G130

Drive converter chassis units

Line-side power components Recommended line-side system components

Overview

The table below lists recommended ratings for input-end switching and fuse protection elements for compliance with IEC standards.

Additional information about the line contactors, switch disconnectors, fuses and circuit-breakers specified in the table can be found in Catalog LV 10.1.

Type rating (at 400 V, 500 V or 690 V)	Rated input current	Matching Power Module	Line contactor	Fixed-mounted circuit breaker	Switch disconnectors
kW	A		Type	Type	Type
380 ... 480 V 3 AC					
110	229	6SL3310-1GE32-1AA3	3RT1456-.....	-	3KL5530-.....
132	284	6SL3310-1GE32-6AA3	3RT1466-.....	-	3KL5730-.....
160	338	6SL3310-1GE33-1AA3	3RT1466-.....	-	3KL5730-.....
200	395	6SL3310-1GE33-8AA3	3RT1476-.....	-	3KL6130-.....
250	509	6SL3310-1GE35-0AA3	3RT1476-.....	-	3KL6130-.....
315	629	6SL3310-1GE36-1AA3	3RT1476-.....	-	3KL6230-.....
400	775	6SL3310-1GE37-5AA3	3RT1466-..... (3 units)	-	3KL6230-.....
450	873	6SL3310-1GE38-4AA3	-	3WL1110-...	-
560	1024	6SL3310-1GE41-0AA3	-	3WL1112-...	-
500 ... 600 V 3 AC					
110	191	6SL3310-1GF31-8AA3	3RT1456-.....	-	3KL5530-.....
132	242	6SL3310-1GF32-2AA3	3RT1456-.....	-	3KL5530-.....
160	270	6SL3310-1GF32-6AA3	3RT1466-.....	-	3KL5730-.....
200	343	6SL3310-1GF33-3AA3	3RT1466-.....	-	3KL5730-.....
250	426	6SL3310-1GF34-1AA3	3RT1476-.....	-	3KL6130-.....
315	483	6SL3310-1GF34-7AA3	3RT1476-.....	-	3KL6130-.....
400	598	6SL3310-1GF35-8AA3	3RT1476-.....	-	3KL6230-.....
500	764	6SL3310-1GF37-4AA3	3RT1466-..... (3 units)	-	3KL6230-.....
560	842	6SL3310-1GF38-1AA3	-	3WL1210-...	-
660 ... 690 V 3 AC					
75	93	6SL3310-1GH28-5AA3	3RT1446-.....	-	3KL5230-.....
90	109	6SL3310-1GH31-0AA3	3RT1446-.....	-	3KL5230-.....
110	131	6SL3310-1GH31-2AA3	3RT1446-.....	-	3KL5530-.....
132	164	6SL3310-1GH31-5AA3	3RT1456-.....	-	3KL5530-.....
160	191	6SL3310-1GH31-8AA3	3RT1456-.....	-	3KL5530-.....
200	224	6SL3310-1GH32-2AA3	3RT1456-.....	-	3KL5530-.....
250	270	6SL3310-1GH32-6AA3	3RT1466-.....	-	3KL5730-.....
315	343	6SL3310-1GH33-3AA3	3RT1466-.....	-	3KL5730-.....
400	426	6SL3310-1GH34-1AA3	3RT1476-.....	-	3KL6130-.....
450	483	6SL3310-1GH34-7AA3	3RT1476-.....	-	3KL6130-.....
560	598	6SL3310-1GH35-8AA3	3RT1476-.....	-	3KL6230-.....
710	764	6SL3310-1GH37-4AA3	3RT1466-..... (3 units)	-	3KL6230-.....
800	842	6SL3310-1GH38-1AA3	-	3WL1210-...	-

SINAMICS G130

Drive converter chassis units

Line-side power components
Recommended line-side system components

Overview (continued)

Type rating (at 400 V, 500 V or 690 V)	Rated input current	Matching Power Module	Cable protection fuse		Cable protection fuse incl. semiconductor protection	
			Type	Rated current A	Type	Rated current A
kW	A		Type	A	Type	A
380 ... 480 V 3 AC						
110	229	6SL3310-1GE32-1AA3	3NA3144	250	3NE1230-2	315
132	284	6SL3310-1GE32-6AA3	3NA3250	300	3NE1331-2	350
160	338	6SL3310-1GE33-1AA3	3NA3254	355	3NE1334-2	500
200	395	6SL3310-1GE33-8AA3	3NA3260	400	3NE1334-2	500
250	509	6SL3310-1GE35-0AA3	3NA3372	630	3NE1436-2	630
315	629	6SL3310-1GE36-1AA3	3NA3475	800	3NE1438-2	800
400	775	6SL3310-1GE37-5AA3	3NA3475	800	3NE1448-2	850
450	873	6SL3310-1GE38-4AA3	3NA3365	2 x 500	3NE1436-2	2 x 630
560	1024	6SL3310-1GE41-0AA3	3NA3472	2 x 630	3NE1437-2	2 x 710
500 ... 600 V 3 AC						
110	191	6SL3310-1GF31-8AA3	3NA3244-6	250	3NE1227-2	250
132	242	6SL3310-1GF32-2AA3	3NA3252-6	315	3NE1230-2	315
160	270	6SL3310-1GF32-6AA3	3NA3354-6	355	3NE1331-2	350
200	343	6SL3310-1GF33-3AA3	3NA3365-6	500	3NE1334-2	500
250	426	6SL3310-1GF34-1AA3	3NA3365-6	500	3NE1334-2	500
315	483	6SL3310-1GF34-7AA3	3NA3252-6	2 x 315	3NE1435-2	560
400	598	6SL3310-1GF35-8AA3	3NA3354-6	2 x 355	3NE1447-2	670
500	764	6SL3310-1GF37-4AA3	3NA3365-6	2 x 500	3NE1448-2	850
560	842	6SL3310-1GF38-1AA3	3NA3365-6	2 x 500	3NE1334-2	2 x 500
660 ... 690 V 3 AC						
75	93	6SL3310-1GH28-5AA3	3NA3132-6	125	3NE1022-2	125
90	109	6SL3310-1GH31-0AA3	3NA3132-6	125	3NE1022-2	125
110	131	6SL3310-1GH31-2AA3	3NA3136-6	160	3NE1224-2	160
132	164	6SL3310-1GH31-5AA3	3NA3240-6	200	3NE1225-2	200
160	191	6SL3310-1GH31-8AA3	3NA3244-6	250	3NE1227-2	250
200	224	6SL3310-1GH32-2AA3	3NA3252-6	315	3NE1230-2	315
250	270	6SL3310-1GH32-6AA3	3NA3354-6	355	3NE1331-2	350
315	343	6SL3310-1GH33-3AA3	3NA3365-6	500	3NE1334-2	500
400	426	6SL3310-1GH34-1AA3	3NA3365-6	500	3NE1334-2	500
450	483	6SL3310-1GH34-7AA3	3NA3252-6	2 x 315	3NE1435-2	560
560	598	6SL3310-1GH35-8AA3	3NA3354-6	2 x 355	3NE1447-2	670
710	764	6SL3310-1GH37-4AA3	3NA3365-6	2 x 500	3NE1448-2	850
800	842	6SL3310-1GH38-1AA3	3NA3365-6	2 x 500	3NE1334-2	2 x 500

SINAMICS G130

Drive converter chassis units

DC link components Braking Modules

Overview



A Braking Module and the matching braking resistor are needed by the drive when it brakes or needs to be stopped for a specific reason, e.g. for an Emergency Stop.

The Braking Module houses the power electronics and the associated control circuit. The supply voltage for the electronics is drawn from the DC link.

During operation, the DC link power is converted into heat loss in an external braking resistor.

The Braking Module works autonomously from the converter control. If more braking power is required than provided by the Braking Modules listed here, then braking units may be connected in parallel for higher converter outputs (on request). In this case, one Braking Module is assigned to each braking resistor.

The activation threshold of the Braking Module can be adjusted using the DIP switch. The braking power values specified in the technical data apply to the upper activation threshold.

Design

The Braking Module is inserted in a slot inside the Power Module; it is force-cooled by the Power Module fan.

Several Braking Modules can be used for Power Modules with more than one power block:

- Frame size HX: 2 Braking Modules
- Frame size JX: 3 Braking Modules

A Braking Module is always assigned its own dedicated braking resistor.

The Braking Module is connected to the DC link using the busbars or flexible cables supplied with the module.

The Braking Module has the following interfaces as standard:

- DC link connection
- Braking resistor connection terminal
- 1 digital input (inhibit Braking Module/acknowledge error)
- 1 digital output (fault in Braking Module)
- 1 DIP switch for adjusting the activation threshold

Information about Braking Module activation thresholds and more detailed configuring instructions is included in the SINAMICS Low Voltage Engineering Manual. The Engineering Manual is stored as a PDF file on the CD-ROM included with the catalog.

Selection and ordering data

Suitable for Power Module	Type rating of the Power Module at 400 V, 500 V or 690 V kW	Braking Module Order No.
380 ... 480 V 3 AC		
6SL3310-1GE32-1AA3	110	6SL3300-1AE31-3AA0
6SL3310-1GE32-6AA3	132	
6SL3310-1GE33-1AA3	160	6SL3300-1AE32-5AA0
6SL3310-1GE33-8AA3	200	
6SL3310-1GE35-0AA3	250	
6SL3310-1GE36-1AA3	315	6SL3300-1AE32-5BA0
6SL3310-1GE37-5AA3	400	
6SL3310-1GE38-4AA3	450	
6SL3310-1GE41-0AA3	560	
500 ... 600 V 3 AC		
6SL3310-1GF31-8AA3	110	6SL3300-1AF32-5AA0
6SL3310-1GF32-2AA3	132	
6SL3310-1GF32-6AA3	160	
6SL3310-1GF33-3AA3	200	
6SL3310-1GF34-1AA3	250	6SL3300-1AF32-5BA0
6SL3310-1GF34-7AA3	315	
6SL3310-1GF35-8AA3	400	
6SL3310-1GF37-4AA3	500	
6SL3310-1GF38-1AA3	560	
660 ... 690 V 3 AC		
6SL3310-1GH28-5AA3	75	6SL3300-1AH31-3AA0
6SL3310-1GH31-0AA3	90	
6SL3310-1GH31-2AA3	110	
6SL3310-1GH31-5AA3	132	
6SL3310-1GH31-8AA3	160	6SL3300-1AH32-5AA0
6SL3310-1GH32-2AA3	200	
6SL3310-1GH32-6AA3	250	
6SL3310-1GH33-3AA3	315	
6SL3310-1GH34-1AA3	400	6SL3300-1AH32-5BA0
6SL3310-1GH34-7AA3	450	
6SL3310-1GH35-8AA3	560	
6SL3310-1GH37-4AA3	710	
6SL3310-1GH38-1AA3	800	

Integration

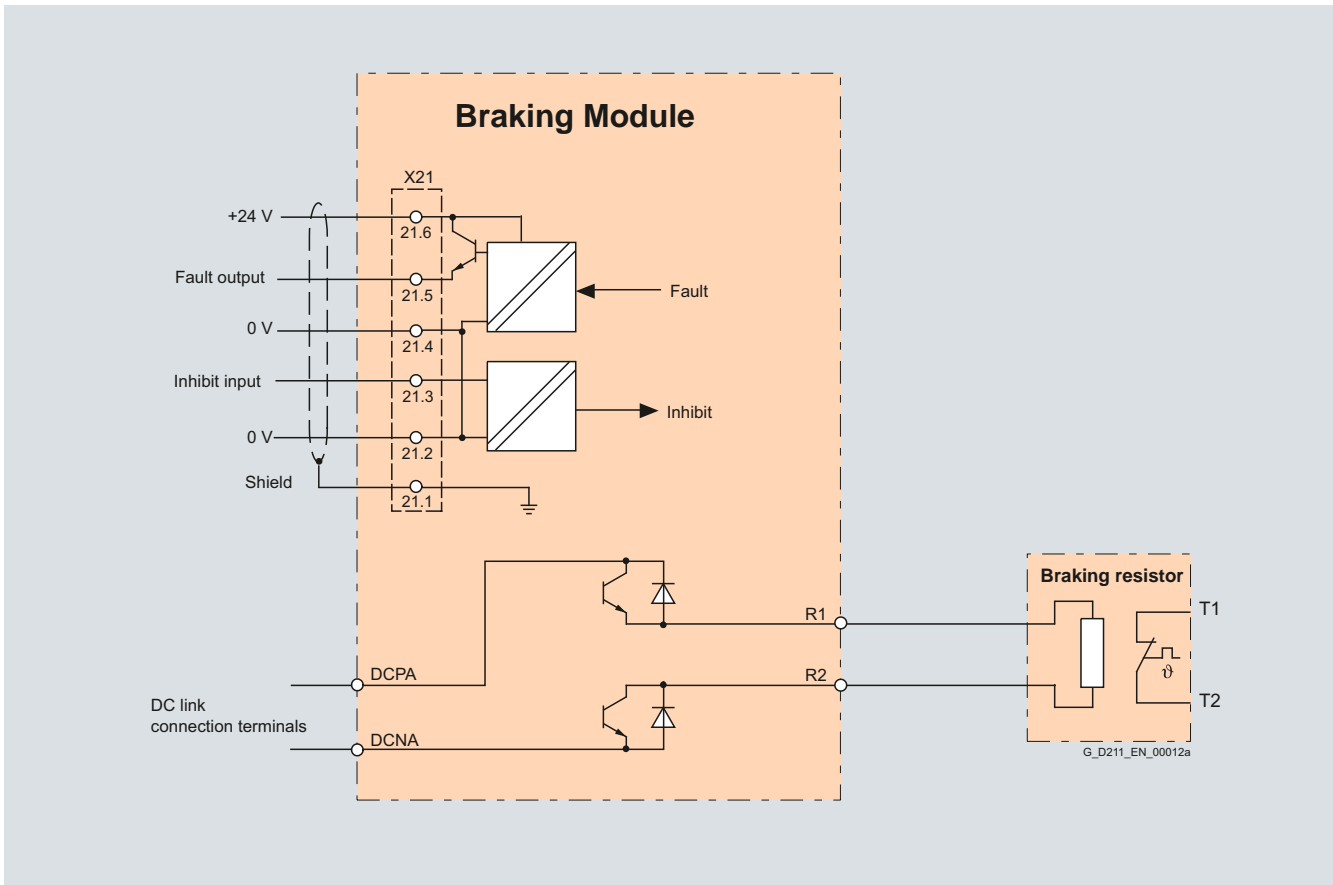

Connection diagram for Braking Module

Characteristic curves

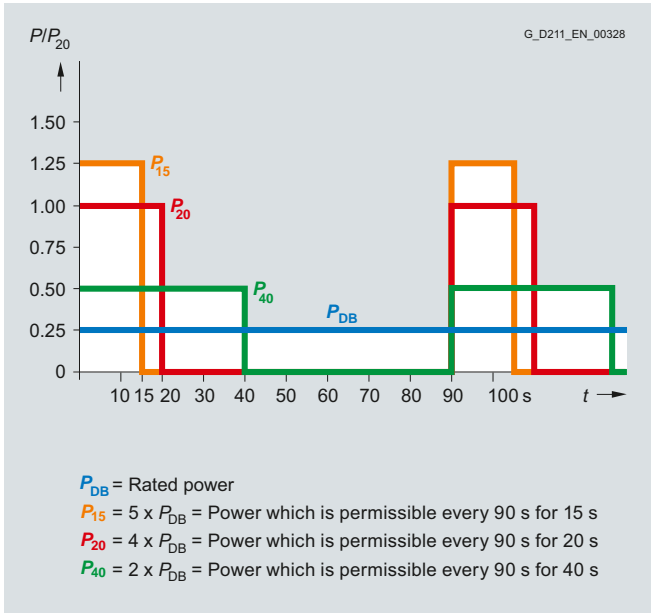

Load diagram for Braking Modules and braking resistors

SINAMICS G130

Drive converter chassis units

DC link components Braking Modules

Technical data

		Braking Module				
		6SL3300-1AE31-3AA0	6SL3300-1AE32-5AA0 6SL3300-1AE32-5BA0	6SL3300-1AF32-5AA0 6SL3300-1AF32-5BA0	6SL3300-1AH31-3AA0	6SL3300-1AH32-5AA0 6SL3300-1AH32-5BA0
Line voltage		3 AC 380 ... 480 V		3 AC 500 ... 600 V	3 AC 660 ... 690 V	
Rated power P_{DB}	kW	25	50	50	25	50
Peak power P_{15}	kW	125	250	250	125	250
Power P_{20}	kW	100	200	200	100	200
Power P_{40}	kW	50	100	100	50	100
Activation thresholds (adjustable via DIP switch)	V	774 (factory setting) or 673	774 (factory setting) or 673	967 (factory setting) or 841	1158 (factory setting) or 1070	1158 (factory setting) or 1070
Digital inputs						
• Voltage	V	24	24	24	24	24
• Low level (an open digital input is interpreted as "low")	V	-3 ... +5	-3 ... +5	-3 ... +5	-3 ... +5	-3 ... +5
• High level	V	15 ... 30	15 ... 30	15 ... 30	15 ... 30	15 ... 30
• Current consumption at 24 V DC, typ.	mA	10	10	10	10	10
• Conductor cross section, max. (IEC)	mm ²	1.5	1.5	1.5	1.5	1.5
Digital outputs (continuously short-circuit-proof)						
• Voltage	V	24	24	24	24	24
• Load current per digital output, max.	mA	500	500	500	500	500
• Conductor cross section, max. (IEC)	mm ²	1.5	1.5	1.5	1.5	1.5
Design conforms to		UL and IEC	UL and IEC	UL and IEC	IEC	IEC
R1/R2 connection		M8 nut	M8 nut	M8 nut	M8 nut	M8 nut
• Conductor cross section, max. (IEC)	mm ²	35	50	50	35	50
Weight, approx.	kg	3.6	7.3 (6SL3300-1AE32-5AA0) 7.5 (6SL3300-1AE32-5BA0)	7.3 (6SL3300-1AF32-5AA0) 7.5 (6SL3300-1AF32-5BA0)	3.6	7.3 (6SL3300-1AH32-5AA0) 7.5 (6SL3300-1AH32-5BA0)
Conformity		CE	CE	CE	CE	CE
Approvals, acc. to		cULus	cULus	cULus	-	-
Braking Module		6SL3300-1AE31-3AA0	6SL3300-1AE32-5AA0	6SL3300-1AF32-5AA0	6SL3300-1AH31-3AA0	6SL3300-1AH32-5AA0
Suitable for Power Module		6SL3310-1GE32-1AA3 (110 kW) 6SL3310-1GE32-6AA3 (132 kW)	6SL3310-1GE33-1AA3 (160 kW) 6SL3310-1GE33-8AA3 (200 kW) 6SL3310-1GE35-0AA3 (250 kW)	6SL3310-1GF31-8AA3 (110 kW) 6SL3310-1GF32-2AA3 (132 kW) 6SL3310-1GF32-6AA3 (160 kW) 6SL3310-1GF33-3AA3 (200 kW)	6SL3310-1GH28-5AA3 (75 kW) 6SL3310-1GH31-0AA3 (90 kW) 6SL3310-1GH31-2AA3 (110 kW) 6SL3310-1GH31-5AA3 (132 kW)	6SL3310-1GH31-8AA3 (160 kW) 6SL3310-1GH32-2AA3 (200 kW) 6SL3310-1GH32-6AA3 (250 kW) 6SL3310-1GH33-3AA3 (315 kW)
Braking Module			6SL3300-1AE32-5BA0	6SL3300-1AF32-5BA0		6SL3300-1AH32-5BA0
Suitable for Power Module			6SL3310-1GE36-1AA3 (315 kW) 6SL3310-1GE37-5AA3 (400 kW) 6SL3310-1GE38-4AA3 (450 kW) 6SL3310-1GE41-0AA3 (560 kW)	6SL3310-1GF34-1AA3 (250 kW) 6SL3310-1GF34-7AA3 (315 kW) 6SL3310-1GF35-8AA3 (400 kW) 6SL3310-1GF37-4AA3 (500 kW) 6SL3310-1GF38-1AA3 (560 kW)		6SL3310-1GH34-1AA3 (400 kW) 6SL3310-1GH34-7AA3 (450 kW) 6SL3310-1GH35-8AA3 (560 kW) 6SL3310-1GH37-4AA3 (710 kW) 6SL3310-1GH38-1AA3 (800 kW)

SINAMICS G130

Drive converter chassis units

DC link components

Braking resistors

Overview



The excess energy of the DC link is dissipated via the braking resistor.

The braking resistor is connected to a Braking Module. The braking resistor is positioned outside the cabinet or switchgear room. This enables the resulting heat loss around the Power Modules to be dissipated, thereby allowing a corresponding reduction in the level of air conditioning required.

2 braking resistors with different rated and peak power values are available for the units.

The braking resistor is monitored on the basis of the duty cycle. A temperature switch (NC contact) is also fitted. This responds when the maximum permissible temperature is exceeded and can be evaluated by a controller. The maximum permissible cable length between the Braking Module and braking resistor is 100 m.

Information on possible load cycles of the braking resistors as well as additional project guidelines are provided in the SINAMICS Low Voltage Engineering Manual, which is available as a PDF file on the CD-ROM included with the catalog.

Selection and ordering data

P_{DB} rated power kW	Suitable for Braking Module	Braking resistor Order No.
Line voltage 380 ... 480 V 3 AC		
25	6SL3300-1AE31-3AA0	6SL3000-1BE31-3AA0
50	6SL3300-1AE32-5.A0	6SL3000-1BE32-5AA0
Line voltage 500 ... 600 V 3 AC		
50	6SL3300-1AF32-5.A0	6SL3000-1BF32-5AA0
Line voltage 660 ... 690 V 3 AC		
25	6SL3300-1AH31-3AA0	6SL3000-1BH31-3AA0
50	6SL3300-1AH32-5.A0	6SL3000-1BH32-5AA0

Characteristic curves

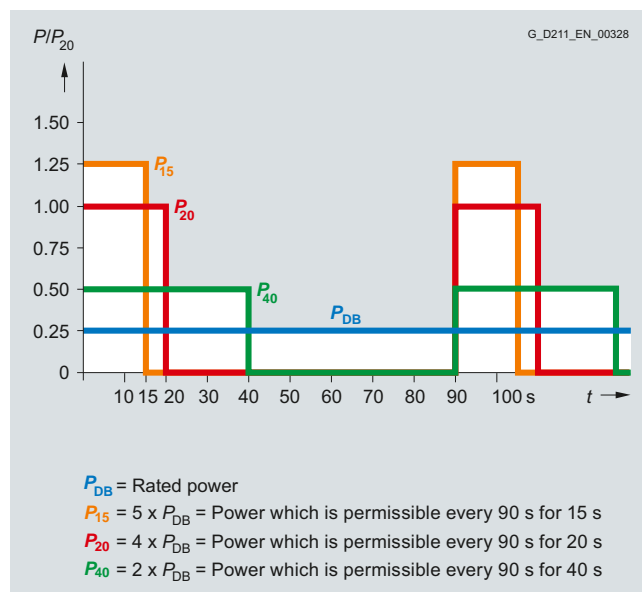

Load diagram for Braking Modules and braking resistor

Technical data

Line voltage 380 ... 480 V 3 AC	Braking resistor		
	6SL3000-1BE31-3AA0	6SL3000-1BE32-5AA0	
Resistor	Ω	4.4 ($\pm 7.5\%$)	2.2 ($\pm 7.5\%$)
P_{DB} rated power (continuous braking power)	kW	25	50
P_{15} power	kW	125	250
P_{20} power	kW	100	200
P_{40} power	kW	50	100
Current, max.	A	189	378
Conductor cross section, max. (IEC)	mm ²	50	70
Power connection		M10 stud	M10 stud
Degree of protection		IP20	IP20
Dimensions			
• Width	mm	740	810
• Height	mm	600	1325
• Depth	mm	486	486
Weight, approx.	kg	50	120
Conformity		CE	CE
Approvals, acc. to		cURus	cURus
Suitable for Braking Module		6SL3300-1AE31-3AA	6SL3300-1AE32-5.A0

SINAMICS G130

Drive converter chassis units

DC link components Braking resistors

Technical data (continued)

Line voltage 500 ... 600 V 3 AC		Braking resistor 6SL3000-1BF32-5AA0	
Resistor	Ω	3.4 (±7.5 %)	
P_{DB} rated power (continuous braking power)	kW	50	
P_{15} power	kW	250	
P_{20} power	kW	200	
P_{40} power	kW	100	
Current, max.	A	255	
Conductor cross section, max. (IEC)	mm ²	70	
Power connection		M10 stud	
Degree of protection		IP20	
Dimensions			
• Width	mm	810	
• Height	mm	1325	
• Depth	mm	486	
Weight, approx.	kg	120	
Conformity		CE	
Approvals, acc. to		cURus	
Suitable for Braking Module		6SL3300-1AF32-5.A0	

Line voltage 660 ... 690 V 3 AC		Braking resistor 6SL3000-1BH31-3AA0		Braking resistor 6SL3000-1BH32-5AA0	
Resistor	Ω	9.8 (±7.5 %)		4.9 (±7.5 %)	
P_{DB} rated power (continuous braking power)	kW	25		50	
P_{15} power	kW	125		250	
P_{20} power	kW	100		200	
P_{40} power	kW	50		100	
Current, max.	A	125		255	
Conductor cross section, max. (IEC)	mm ²	50		70	
Power connection		M10 stud		M10 stud	
Degree of protection		IP20		IP20	
Dimensions					
• Width	mm	740		810	
• Height	mm	600		1325	
• Depth	mm	486		486	
Weight, approx.	kg	50		120	
Conformity		CE		CE	
Approvals, acc. to		cURus		cURus	
Suitable for Braking Module		6SL3300-1AH31-3AA0		6SL3300-1AH32-5.A0	

SINAMICS G130

Drive converter chassis units

Load-side power components

Motor reactors

Overview



Motor reactors reduce the voltage load on the motor windings by reducing the voltage gradients on the motor terminals generated when the converter is used. At the same time, the capacitive charge/discharge currents that place an additional load on the converter output when long motor cables are used are reduced. The maximum permissible output frequency when a motor reactor is used is 150 Hz.

The motor reactor must be installed as close as possible to the Power Module.

Selection and ordering data

Suitable for Power Module	Type rating of the Power Module at 400 V, 500 V or 690 V kW	Motor reactor Order No.
380 ... 480 V 3 AC		
6SL3310-1GE32-1AA3	110	6SL3000-2BE32-1AA0
6SL3310-1GE32-6AA3	132	6SL3000-2BE32-6AA0
6SL3310-1GE33-1AA3	160	6SL3000-2BE33-2AA0
6SL3310-1GE33-8AA3	200	6SL3000-2BE33-8AA0
6SL3310-1GE35-0AA3	250	6SL3000-2BE35-0AA0
6SL3310-1GE36-1AA3	315	6SL3000-2AE36-1AA0
6SL3310-1GE37-5AA3	400	6SL3000-2AE38-4AA0
6SL3310-1GE38-4AA3	450	
6SL3310-1GE41-0AA3	560	6SL3000-2AE41-0AA0
500 ... 600 V 3 AC		
6SL3310-1GF31-8AA3	110	6SL3000-2AH31-8AA0
6SL3310-1GF32-2AA3	132	6SL3000-2AH32-4AA0
6SL3310-1GF32-6AA3	160	6SL3000-2AH32-6AA0
6SL3310-1GF33-3AA3	200	6SL3000-2AH33-6AA0
6SL3310-1GF34-1AA3	250	6SL3000-2AH34-5AA0
6SL3310-1GF34-7AA3	315	6SL3000-2AH34-7AA0
6SL3310-1GF35-8AA3	400	6SL3000-2AH35-8AA0
6SL3310-1GF37-4AA3	500	6SL3000-2AH38-1AA0
6SL3310-1GF38-1AA3	560	
660 ... 690 V 3 AC		
6SL3310-1GH28-5AA3	75	6SL3000-2AH31-0AA0
6SL3310-1GH31-0AA3	90	
6SL3310-1GH31-2AA3	110	6SL3000-2AH31-5AA0
6SL3310-1GH31-5AA3	132	
6SL3310-1GH31-8AA3	160	6SL3000-2AH31-8AA0
6SL3310-1GH32-2AA3	200	6SL3000-2AH32-4AA0
6SL3310-1GH32-6AA3	250	6SL3000-2AH32-6AA0
6SL3310-1GH33-3AA3	315	6SL3000-2AH33-6AA0
6SL3310-1GH34-1AA3	400	6SL3000-2AH34-5AA0
6SL3310-1GH34-7AA3	450	6SL3000-2AH34-7AA0
6SL3310-1GH35-8AA3	560	6SL3000-2AH35-8AA0
6SL3310-1GH37-4AA3	710	6SL3000-2AH38-1AA0
6SL3310-1GH38-1AA3	800	

SINAMICS G130

Drive converter chassis units

Load-side power components Motor reactors

Technical data

Line voltage 380 ... 480 V 3 AC		Motor reactor (for pulse frequencies of 2 kHz to 4 kHz)				
		6SL3000- 2BE32-1AA0	6SL3000- 2BE32-6AA0	6SL3000- 2BE33-2AA0	6SL3000- 2BE33-8AA0	6SL3000- 2BE35-0AA0
Rated current	A	210	260	310	380	490
Power loss	kW	0.486	0.5	0.47	0.5	0.5
Load connection		1 × hole for M10	1 × hole for M10	1 × hole for M10	1 × hole for M10	1 × hole for M12
PE connection		M8 screw	M8 screw	M8 screw	M8 screw	M8 screw
Cable length, max. between motor reactor and motor ¹⁾						
• shielded	m	300	300	300	300	300
• unshielded	m	450	450	450	450	450
Degree of protection		IP00	IP00	IP00	IP00	IP00
Dimensions						
• Width	mm	300	300	300	300	300
• Height	mm	285	315	285	285	365
• Depth	mm	257	277	257	277	277
Weight, approx.	kg	60	66	62	73	100
Approvals, acc. to		cURus	cURus	cURus	cURus	cURus
Suitable for Power Module		6SL3310- 1GE32-1AA3 (110 kW)	6SL3310- 1GE32-6AA3 (132 kW)	6SL3310- 1GE33-1AA3 (160 kW)	6SL3310- 1GE33-8AA3 (200 kW)	6SL3310- 1GE35-0AA3 (250 kW)

Line voltage 380 ... 480 V 3 AC		Motor reactor (for pulse frequencies of 1.25 kHz to 2.5 kHz)			
		6SL3000- 2AE36-1AA0	6SL3000-2AE38-4AA0	6SL3000- 2AE41-0AA0	
Rated current	A	605	745	840	985
Power loss	kW	0.9	0.84	0.943	1.062
Load connection		1 × hole for M12	1 × hole for M12	1 × hole for M12	1 × hole for M12
PE connection		M10 screw	M10 screw	M10 screw	M10 screw
Cable length, max. between motor reactor and motor ¹⁾					
• shielded	m	300	300	300	300
• unshielded	m	450	450	450	450
Degree of protection		IP00	IP00	IP00	IP00
Dimensions					
• Width	mm	410	410	410	410
• Height	mm	392	392	392	392
• Depth	mm	292	292	292	302
Weight, approx.	kg	130	140	140	146
Approvals, acc. to		cURus	cURus	cURus	cURus
Suitable for Power Module		6SL3310- 1GE36-1AA3 (315 kW)	6SL3310- 1GE37-5AA3 (400 kW)	6SL3310- 1GE38-4AA3 (450 kW)	6SL3310- 1GE41-0AA3 (560 kW)

¹⁾ Longer cable lengths for specific configurations are available on request.

SINAMICS G130

Drive converter chassis units

Load-side power components
Motor reactors

Technical data (continued)

Line voltage 500 ... 600 V 3 AC		Motor reactor (for pulse frequencies of 1.25 kHz to 2.5 kHz)				
		6SL3000- 2AH31-8AA0	6SL3000- 2AH32-4AA0	6SL3000- 2AH32-6AA0	6SL3000- 2AH33-6AA0	6SL3000- 2AH34-5AA0
Rated current	A	175	215	260	330	410
Power loss	kW	0.403	0.425	0.441	0.454	0.545
Load connection		1 × hole for M10	1 × hole for M10	1 × hole for M10	1 × hole for M10	1 × hole for M10
PE connection		M8 screw	M8 screw	M8 screw	M8 screw	M8 screw
Cable length, max. between motor reactor and motor ¹⁾						
• shielded	m	300	300	300	300	300
• unshielded	m	450	450	450	450	450
Degree of protection		IP00	IP00	IP00	IP00	IP00
Dimensions						
• Width	mm	300	300	300	300	350
• Height	mm	285	285	285	285	330
• Depth	mm	212	212	212	212	215
Weight, approx.	kg	34	34	40	43	56
Approvals, acc. to		cURus	cURus	cURus	cURus	cURus
Suitable for Power Module		6SL3310-1GF31-8AA3 (110 kW)	6SL3310-1GF32-2AA3 (132 kW)	6SL3310-1GF32-6AA3 (160 kW)	6SL3310-1GF33-3AA3 (200 kW)	6SL3310-1GF34-1AA3 (250 kW)

Line voltage 500 ... 600 V 3 AC		Motor reactor (for pulse frequencies of 1.25 kHz to 2.5 kHz)			
		6SL3000- 2AH34-7AA0	6SL3000- 2AH35-8AA0	6SL3000-2AH38-1AA0	
Rated current	A	465	575	735	810
Power loss	kW	0.72	0.8	0.91	1.0
Load connection		1 × hole for M12	1 × hole for M12	1 × hole for M12	1 × hole for M12
PE connection		M8 screw	M8 screw	M8 screw	M8 screw
Cable length, max. between motor reactor and motor ¹⁾					
• shielded	m	300	300	300	300
• unshielded	m	450	450	450	450
Degree of protection		IP00	IP00	IP00	IP00
Dimensions					
• Width	mm	410	410	410	410
• Height	mm	392	392	392	392
• Depth	mm	292	292	279	279
Weight, approx.	kg	80	80	146	146
Approvals, acc. to		cURus	cURus	cURus	cURus
Suitable for Power Module		6SL3310-1GF34-7AA3 (315 kW)	6SL3310-1GF35-8AA3 (400 kW)	6SL3310-1GF37-4AA3 (500 kW)	6SL3310-1GF38-1AA3 (560 kW)

¹⁾ Longer cable lengths for specific configurations are available on request.

SINAMICS G130

Drive converter chassis units

Load-side power components Motor reactors

Technical data (continued)

Line voltage 660 ... 690 V 3 AC		Motor reactor (for pulse frequencies of 1.25 kHz to 2.5 kHz)						
		6SL3000-2AH31-0AA0		6SL3000-2AH31-5AA0		6SL3000-2AH31-8AA0	6SL3000-2AH32-4AA0	6SL3000-2AH32-6AA0
Rated current	A	85	100	120	150	175	215	260
Power loss	kW	0.26	0.3	0.26	0.332	0.403	0.425	0.441
Load connection		1 × hole for M10	1 × hole for M10	1 × hole for M10	1 × hole for M10	1 × hole for M10	1 × hole for M10	1 × hole for M10
PE connection		M8 screw	M8 screw	M8 screw	M8 screw	M8 screw	M8 screw	M8 screw
Cable length, max. between motor reactor and motor ¹⁾								
• shielded	m	300	300	300	300	300	300	300
• unshielded	m	450	450	450	450	450	450	450
Degree of protection		IP00	IP00	IP00	IP00	IP00	IP00	IP00
Dimensions								
• Width	mm	270	270	270	270	300	300	300
• Height	mm	248	248	248	248	285	285	285
• Depth	mm	200	200	200	200	212	212	212
Weight, approx.	kg	26	26	26	26	33	35	40
Approvals, acc. to		-	-	-	-	-	-	-
Suitable for Power Module		6SL3310-1GH28-5AA3 (75 kW)	6SL3310-1GH31-0AA3 (90 kW)	6SL3310-1GH31-2AA3 (110 kW)	6SL3310-1GH31-5AA3 (132 kW)	6SL3310-1GH31-8AA3 (160 kW)	6SL3310-1GH32-2AA3 (200 kW)	6SL3310-1GH32-6AA3 (250 kW)

Line voltage 660 ... 690 V 3 AC		Motor reactor (for pulse frequencies of 1.25 kHz to 2.5 kHz)					
		6SL3000-2AH33-6AA0	6SL3000-2AH34-5AA0	6SL3000-2AH34-7AA0	6SL3000-2AH35-8AA0	6SL3000-2AH38-1AA0	
Rated current	A	330	410	465	575	735	810
Power loss	kW	0.454	0.545	0.723	0.801	0.91	1.003
Load connection		1 × hole for M10	1 × hole for M10	1 × hole for M12	1 × hole for M12	1 × hole for M12	1 × hole for M12
PE connection		M8 screw	M8 screw	M8 screw	M8 screw	M8 screw	M8 screw
Cable length, max. between motor reactor and motor ¹⁾							
• shielded	m	300	300	300	300	300	300
• unshielded	m	450	450	450	450	450	450
Degree of protection		IP00	IP00	IP00	IP00	IP00	IP00
Dimensions							
• Width	mm	300	350	410	410	410	410
• Height	mm	285	330	392	392	392	392
• Depth	mm	212	215	292	292	279	279
Weight, approx.	kg	43	56	80	80	146	146
Approvals, acc. to		-	-	-	-	-	-
Suitable for Power Module		6SL3310-1GH33-3AA3 (315 kW)	6SL3310-1GH34-1AA3 (400 kW)	6SL3310-1GH34-7AA3 (450 kW)	6SL3310-1GH35-8AA3 (560 kW)	6SL3310-1GH37-4AA3 (710 kW)	6SL3310-1GH38-1AA3 (800 kW)

¹⁾ Longer cable lengths for specific configurations are available on request.

SINAMICS G130

Drive converter chassis units

Load-side power components
dv/dt filters plus VPL

Overview

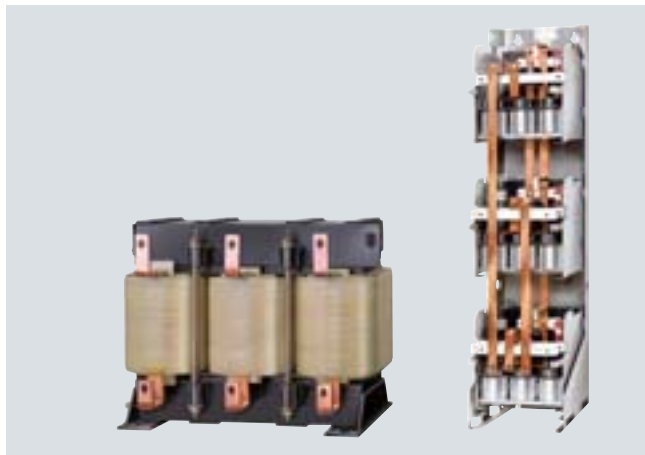

dv/dt filter plus VPL (**V**oltage **P**eak **L**imiter) limit the voltage rate-of-rise dv/dt to values $< 500 \text{ V}/\mu\text{s}$ and the typical voltage peaks to the following values according to the limit value curve to IEC/TS 60034-17: 2006:

- $< 1000 \text{ V}$ at $V_{\text{line}} < 575 \text{ V}$
- $< 1250 \text{ V}$ at $660 \text{ V} < V_{\text{line}} < 690 \text{ V}$.

Standard motors with standard insulation and without insulated bearings with a supply voltage of up to 690 V can be used for converter operation if a dv/dt filter plus VPL is used.

dv/dt filter plus VPL are designed for the following maximum motor cable lengths:

- Shielded cables: 300 m (e.g. Protodur NYCWY)
- Unshielded cables: 450 m (e.g. Protodur NYY)

For shorter cable lengths (100 m shielded, 150 m unshielded) also refer to dv/dt filter compact plus VPL.

Notice:

The max. permissible cable length between the dv/dt filter and Power Module is 5 m.

Design

The dv/dt filter plus VPL consists of two components, which are also separately supplied as mechanical units:

- dv/dt reactor
- Voltage limiting network, which cuts-off the voltage peaks and feeds the energy back into the DC link.

Selection and ordering data

Suitable for Power Module	Type rating of the Power Module at 400 V, 500 V or 690 V kW	dv/dt filter plus VPL Order No.
380 ... 480 V 3 AC		
6SL3310-1GE32-1AA3	110	6SL3000-2DE32-6AA0
6SL3310-1GE32-6AA3	132	
6SL3310-1GE33-1AA3	160	6SL3000-2DE35-0AA0
6SL3310-1GE33-8AA3	200	
6SL3310-1GE35-0AA3	250	
6SL3310-1GE36-1AA3	315	6SL3000-2DE38-4AA0
6SL3310-1GE37-5AA3	400	
6SL3310-1GE38-4AA3	450	
6SL3310-1GE41-0AA3	560	6SL3000-2DE41-4AA0
500 ... 600 V 3 AC		
6SL3310-1GF31-8AA3	110	6SL3000-2DH32-2AA0
6SL3310-1GF32-2AA3	132	
6SL3310-1GF32-6AA3	160	6SL3000-2DH33-3AA0
6SL3310-1GF33-3AA3	200	
6SL3310-1GF34-1AA3	250	6SL3000-2DH34-1AA0
6SL3310-1GF34-7AA3	315	6SL3000-2DH35-8AA0
6SL3310-1GF35-8AA3	400	
6SL3310-1GF37-4AA3	500	6SL3000-2DH38-1AA0
6SL3310-1GF38-1AA3	560	
660 ... 690 V 3 AC		
6SL3310-1GH28-5AA3	75	6SL3000-2DH31-0AA0
6SL3310-1GH31-0AA3	90	
6SL3310-1GH31-2AA3	110	6SL3000-2DH31-5AA0
6SL3310-1GH31-5AA3	132	
6SL3310-1GH31-8AA3	160	6SL3000-2DH32-2AA0
6SL3310-1GH32-2AA3	200	
6SL3310-1GH32-6AA3	250	6SL3000-2DH33-3AA0
6SL3310-1GH33-3AA3	315	
6SL3310-1GH34-1AA3	400	6SL3000-2DH34-1AA0
6SL3310-1GH34-7AA3	450	6SL3000-2DH35-8AA0
6SL3310-1GH35-8AA3	560	
6SL3310-1GH37-4AA3	710	6SL3000-2DH38-1AA0
6SL3310-1GH38-1AA3	800	

The SINAMICS Low Voltage Engineering Manual contains additional information about the dv/dt filters, which is available as a PDF file on the CD-ROM included with the catalog.

SINAMICS G130

Drive converter chassis units

Load-side power components dv/dt filters plus VPL

Technical data

Line voltage 380 ... 480 V 3 AC		dv/dt filter plus VPL			
		6SL3000- 2DE32-6AA0	6SL3000- 2DE35-0AA0	6SL3000- 2DE38-4AA0	6SL3000- 2DE41-4AA0
I_{thmax}	A	260	490	840	1405
Degree of protection		IP00	IP00	IP00	IP00
Cable length, max. between dv/dt filter and motor ¹⁾					
• shielded	m	300	300	300	300
• unshielded	m	450	450	450	450
Conformity		CE	CE	CE	CE
Approvals, acc. to		cURus	cURus	cURus	cURus
dv/dt reactor					
Power loss	kW	0.78	0.963	1.226	1.23
Connections					
• to Power Module		1 × hole M10	1 × hole M12	1 × hole M12	2 × hole M12
• to load		1 × hole M10	1 × hole M12	1 × hole M12	2 × hole M12
• PE		M6 screw	M6 screw	M6 screw	M6 screw
Dimensions					
• Width	mm	410	460	460	445
• Height	mm	370	370	385	385
• Depth	mm	229	275	312	312
Weight, approx.	kg	66	122	149	158
Voltage Peak Limiter (VPL)					
Power loss	kW	0.104	0.152	0.302	0.525
Connections					
• to dv/dt reactor		M8 nut	70 mm ² terminals	1 × hole M8	1 × hole M10
• to DC link		M8 nut	70 mm ² terminals	1 × hole M8	1 × hole M10
• PE		M8 stud	35 mm ² terminals	M8 stud	M8 stud
Dimensions					
• Width	mm	263	392	309	309
• Height	mm	265	285	1313	1313
• Depth	mm	188	210	400	400
Weight, approx.	kg	6	16	48	72
Suitable for Power Module		6SL3310- 1GE32-1AA3 (110 kW) 6SL3310- 1GE32-6AA3 (132 kW)	6SL3310- 1GE33-1AA3 (160 kW) 6SL3310- 1GE33-8AA3 (200 kW) 6SL3310- 1GE35-0AA3 (250 kW)	6SL3310- 1GE36-1AA3 (315 kW) 6SL3310- 1GE37-5AA3 (400 kW) 6SL3310- 1GE38-4AA3 (450 kW)	6SL3310- 1GE41-0AA3 (560 kW)

Note: Two dv/dt reactors are required for Power Modules with a type rating of 560 kW.
The listed technical data refer to one dv/dt reactor.

¹⁾ Longer cable lengths for specific configurations are available on request.

SINAMICS G130

Drive converter chassis units

Load-side power components
dv/dt filters plus VPL

Technical data (continued)

Line voltage 500 ... 600 V 3 AC		dv/dt filter plus VPL				
		6SL3000- 2DH32-2AA0	6SL3000- 2DH33-3AA0	6SL3000- 2DH34-1AA0	6SL3000- 2DH35-8AA0	6SL3000- 2DH38-1AA0
I_{thmax}	A	215	330	410	575	810
Degree of protection		IP00	IP00	IP00	IP00	IP00
Cable length, max. between dv/dt filter and motor ¹⁾						
• shielded	m	300	300	300	300	300
• unshielded	m	450	450	450	450	450
Conformity		CE	CE	CE	CE	CE
Approvals, acc. to		cURus	cURus	cURus	cURus	cURus
dv/dt reactor						
Power loss	kW	0.645	0.661	0.884	0.964	0.927
Connections						
• to Power Module		1 × hole M10	1 × hole M10	1 × hole M12	1 × hole M12	2 × hole M12
• to load		1 × hole M10	1 × hole M10	1 × hole M12	1 × hole M12	2 × hole M12
• PE		M6 screw	M6 screw	M6 screw	M6 screw	M6 screw
Dimensions						
• Width	mm	460	460	460	460	445
• Height	mm	360	360	385	385	385
• Depth	mm	275	275	312	312	312
Weight, approx.	kg	83	135	147	172	160
Voltage Peak Limiter (VPL)						
Power loss	kW	0.113	0.152	0.189	0.241	0.372
Connections						
• to dv/dt reactor		70 mm ² terminals	70 mm ² terminals	1 × hole M8	1 × hole M8	1 × hole M10
• to DC link		70 mm ² terminals	70 mm ² terminals	1 × hole M8	1 × hole M8	1 × hole M10
• PE		35 mm ² terminals	35 mm ² terminals	M8 stud	M8 stud	M8 stud
Dimensions						
• Width	mm	392	392	309	309	309
• Height	mm	285	285	1313	1313	1313
• Depth	mm	210	210	400	400	400
Weight, approx.	kg	16	16	48	48	72
Suitable for Power Module		6SL3310- 1GF31-8AA3 (110 kW)	6SL3310- 1GF32-6AA3 (160 kW)	6SL3310- 1GF34-1AA3 (250 kW)	6SL3310- 1GF34-7AA3 (315 kW)	6SL3310- 1GF37-4AA3 (500 kW)
		6SL3310- 1GF32-2AA3 (132 kW)	6SL3310- 1GF33-3AA3 (200 kW)		6SL3310- 1GF35-8AA3 (400 kW)	6SL3310- 1GF38-1AA3 (560 kW)

Note: Two dv/dt reactors are required for Power Modules with a type rating of 500 kW and 560 kW.
The listed technical data refer to one dv/dt reactor.

¹⁾ Longer cable lengths for specific configurations are available on request.

SINAMICS G130

Drive converter chassis units

Load-side power components dv/dt filters plus VPL

Technical data (continued)

Line voltage 660 ... 690 V 3 AC		dv/dt filter plus VPL			
		6SL3000- 2DH31-0AA0	6SL3000- 2DH31-5AA0	6SL3000- 2DH32-2AA0	6SL3000- 2DH33-3AA0
I_{thmax}	A	100	150	215	330
Degree of protection		IP00	IP00	IP00	IP00
Cable length, max. between dv/dt filter and motor ¹⁾					
• shielded	m	300	300	300	300
• unshielded	m	450	450	450	450
Conformity		CE	CE	CE	CE
Approvals, acc. to		cURus	cURus	cURus	cURus
dv/dt reactor					
Power loss	kW	0.541	0.436	0.645	0.661
Connections					
• to Power Module		1 × hole M10	1 × hole M10	1 × hole M10	1 × hole M10
• to load		1 × hole M10	1 × hole M10	1 × hole M10	1 × hole M10
• PE		M6 screw	M6 screw	M6 screw	M6 screw
Dimensions					
• Width	mm	350	350	460	460
• Height	mm	320	320	360	360
• Depth	mm	227	227	275	275
Weight, approx.	kg	48	50	83	135
Voltage Peak Limiter (VPL)					
Power loss	kW	0.053	0.071	0.113	0.152
Connections					
• to dv/dt reactor		M8 nut	M8 nut	70 mm ² terminals	70 mm ² terminals
• to DC link		M8 nut	M8 nut	70 mm ² terminals	70 mm ² terminals
• PE		M8 stud	M8 stud	35 mm ² terminals	35 mm ² terminals
Dimensions					
• Width	mm	263	263	392	392
• Height	mm	265	265	285	285
• Depth	mm	188	188	210	210
Weight, approx.	kg	6	6	16	16
Suitable for Power Module		6SL3310-1GH28-5AA3 (75 kW) 6SL3310-1GH31-0AA3 (90 kW)	6SL3310-1GH31-2AA3 (110 kW) 6SL3310-1GH31-5AA3 (132 kW)	6SL3310-1GH31-8AA3 (160 kW) 6SL3310-1GH32-2AA3 (200 kW)	6SL3310-1GH32-6AA3 (250 kW) 6SL3310-1GH33-3AA3 (315 kW)

¹⁾ Longer cable lengths for specific configurations are available on request.

SINAMICS G130

Drive converter chassis units

Load-side power components
dv/dt filters plus VPL

Technical data (continued)

Line voltage 660 ... 690 V 3 AC		dv/dt filter plus VPL		
		6SL3000- 2DH34-1AA0	6SL3000- 2DH35-8AA0	6SL3000- 2DH38-1AA0
I_{thmax}	A	410	575	810
Degree of protection		IP00	IP00	IP00
Cable length, max. between dv/dt filter and motor ¹⁾				
• shielded	m	300	300	300
• unshielded	m	450	450	450
Conformity		CE	CE	CE
Approvals, acc. to		cURus	cURus	cURus
dv/dt reactor				
Power loss	kW	0.884	0.964	0.927
Connections				
• to Power Module		1 × hole M12	1 × hole M12	2 × hole M12
• to load		1 × hole M12	1 × hole M12	2 × hole M12
• PE		M6 screw	M6 screw	M6 screw
Dimensions				
• Width	mm	460	460	445
• Height	mm	385	385	385
• Depth	mm	312	312	312
Weight, approx.	kg	147	172	160
Voltage Peak Limiter (VPL)				
Power loss	kW	0.189	0.241	0.372
Connections				
• to dv/dt reactor		1 × hole M8	1 × hole M8	1 × hole M10
• to DC link		1 × hole M8	1 × hole M8	1 × hole M10
• PE		M8 stud	M8 stud	M8 stud
Dimensions				
• Width	mm	309	309	309
• Height	mm	1313	1313	1313
• Depth	mm	400	400	400
Weight, approx.	kg	48	48	72
Suitable for Power Module		6SL3310- 1GH34-1AA3 (400 kW)	6SL3310- 1GH34-7AA3 (450 kW) 6SL3310- 1GH35-8AA3 (560 kW)	6SL3310- 1GH37-4AA3 (710 kW) 6SL3310- 1GH38-1AA3 (800 kW)

Note: Two dv/dt reactors are required for Power Modules with a type rating of 710 kW and 800 kW.
The listed technical data refer to one dv/dt reactor.

¹⁾ Longer cable lengths for specific configurations are available on request.

SINAMICS G130

Drive converter chassis units

Load-side power components dv/dt filters compact plus VPL

Overview



dv/dt filter compact plus VPL (**V**oltage **P**eak **L**imiter) limit the voltage rate-of-rise dv/dt to values $< 1600 \text{ V}/\mu\text{s}$ and the typical voltage peaks to the following values according to the limit value curve A to IEC 60034-25: 2007:

- $< 1150 \text{ V}$ at $V_{\text{line}} < 575 \text{ V}$
- $< 1400 \text{ V}$ at $660 \text{ V} < V_{\text{line}} < 690 \text{ V}$.

Standard motors with standard insulation and without insulated bearings with a supply voltage of up to 690 V can be used for converter operation if a dv/dt filter compact plus VPL is used.

dv/dt filter compact plus VPL are designed for the following maximum motor cable lengths:

- Shielded cables: 100 m (e.g. Protodur NYCWY)
- Unshielded cables: 150 m (e.g. Protodur NYY)

For longer cable lengths ($> 100 \text{ m}$ shielded, $> 150 \text{ m}$ unshielded) refer to dv/dt filter plus VPL.

Notice:

- The max. permissible cable length between the dv/dt filter and Power Module is 5 m.
- Operation with output frequencies $< 10 \text{ Hz}$ is permissible for max. 5 min.

Design

The dv/dt filter compact plus VPL consists of two components, which are supplied together as a compact mechanical unit:

- dv/dt reactor
- Voltage limiting network, which cuts-off the voltage peaks and feeds the energy back into the DC link.

Selection and ordering data

Suitable for Power Module	Type rating of the Power Module at 400 V, 500 V or 690 V kW	dv/dt filter compact plus VPL Order No.
380 ... 480 V 3 AC		
6SL3310-1GE32-1AA3	110	6SL3000-2DE32-6EA0
6SL3310-1GE32-6AA3	132	
6SL3310-1GE33-1AA3	160	6SL3000-2DE35-0EA0
6SL3310-1GE33-8AA3	200	
6SL3310-1GE35-0AA3	250	
6SL3310-1GE36-1AA3	315	6SL3000-2DE38-4EA0
6SL3310-1GE37-5AA3	400	
6SL3310-1GE38-4AA3	450	
6SL3310-1GE41-0AA3	560	6SL3000-2DE41-4EA0
500 ... 600 V 3 AC		
6SL3310-1GF31-8AA3	110	6SL3000-2DG32-2EA0
6SL3310-1GF32-2AA3	132	
6SL3310-1GF32-6AA3	160	6SL3000-2DG33-3EA0
6SL3310-1GF33-3AA3	200	
6SL3310-1GF34-1AA3	250	6SL3000-2DG34-1EA0
6SL3310-1GF34-7AA3	315	6SL3000-2DG35-8EA0
6SL3310-1GF35-8AA3	400	
6SL3310-1GF37-4AA3	500	6SL3000-2DG38-1EA0
6SL3310-1GF38-1AA3	560	
660 ... 690 V 3 AC		
6SL3310-1GH28-5AA3	75	6SL3000-2DG31-0EA0
6SL3310-1GH31-0AA3	90	
6SL3310-1GH31-2AA3	110	6SL3000-2DG31-5EA0
6SL3310-1GH31-5AA3	132	
6SL3310-1GH31-8AA3	160	6SL3000-2DG32-2EA0
6SL3310-1GH32-2AA3	200	
6SL3310-1GH32-6AA3	250	6SL3000-2DG33-3EA0
6SL3310-1GH33-3AA3	315	
6SL3310-1GH34-1AA3	400	6SL3000-2DG34-1EA0
6SL3310-1GH34-7AA3	450	6SL3000-2DG35-8EA0
6SL3310-1GH35-8AA3	560	
6SL3310-1GH37-4AA3	710	6SL3000-2DG38-1EA0
6SL3310-1GH38-1AA3	800	

The SINAMICS Low Voltage Engineering Manual contains additional information about the dv/dt filters, which is available as a PDF file on the CD-ROM included with the catalog.

SINAMICS G130

Drive converter chassis units

Load-side power components
dv/dt filters compact plus VPL

Technical data

Line voltage 380 ... 480 V 3 AC		dv/dt filter compact plus VPL			
		6SL3000-2DE32-6EA0	6SL3000-2DE35-0EA0	6SL3000-2DE38-4EA0	6SL3000-2DE41-1EA0
Rated current	A	260	490	840	1405
I_{thmax}	A	260	490	840	1405
Power loss, max.					
• at 50 Hz 400 V	kW	0.21	0.29	0.518	Reactor: 1.027 VPL: 0.127 Total: 1.154
• at 60 Hz 460 V	kW	0.215	0.296	0.529	Reactor: 1.077 VPL: 0.12 Total: 1.197
• at 150 Hz 400 V	kW	0.255	0.344	0.609	Reactor: 1.354 VPL: 0.09 Total: 1.444
Power connection, input and output sides		Hole for M10	Hole for M10	Hole for M12	2 x elongated hole, 14 x 18 mm
• Conductor cross-section, max. (IEC)		Provided for busbar connection	Provided for busbar connection	Provided for busbar connection	Provided for busbar connection
DC link connection, DCPS, DCNS		Threaded socket M8	Threaded socket M8	Hole for M8	Hole for M8
• Conductor cross-section, max. (IEC)		mm ² 16	25	50	95
PE/GND connection		Threaded socket M6	Threaded socket M6	Threaded socket M6	Threaded socket M6 (reactor and VPL)
Cable length, max. between dv/dt filter and motor					
• shielded		m 100	100	100	100
• unshielded		m 150	150	150	150
Degree of protection		IP00	IP00	IP00	IP00
Dimensions					
• Width		mm 310	350	440	Reactor: 430 VPL: 277
• Height		mm 283	317	369	Reactor: 385 VPL: 360
• Depth		mm 238	260	311	Reactor: 323 VPL: 291
Weight, approx.		kg 41	61	103	Reactor: 168.8 VPL: 19.2 Total: 188
Approvals, acc. to		UL CSA (available soon)	UL CSA (available soon)	UL CSA (available soon)	UL CSA (available soon)
Suitable for Power Module		6SL3310-1GE32-1AA3 (110 kW) 6SL3310-1GE32-6AA3 (132 kW)	6SL3310-1GE33-1AA3 (160 kW) 6SL3310-1GE33-8AA3 (200 kW) 6SL3310-1GE35-0AA3 (250 kW)	6SL3310-1GE36-1AA3 (315 kW) 6SL3310-1GE37-5AA3 (400 kW) 6SL3310-1GE38-4AA3 (450 kW)	6SL3310-1GE41-0AA3 (560 kW)

SINAMICS G130

Drive converter chassis units

Load-side power components dv/dt filters compact plus VPL

Technical data (continued)

Line voltage 500 ... 690 V 3 AC	dv/dt filter compact plus VPL				
	6SL3000-2DG31-0EA0	6SL3000-2DG31-5EA0	6SL3000-2DG32-2EA0	6SL3000-2DG33-3EA0	
Rated current	A	100	150	215	330
I_{thmax}	A	100	150	215	330
Power loss, max.					
• at 50 Hz 500/690 V	kW	0.227	0.27	0.305	0.385
• at 60 Hz 575 V	kW	0.236	0.279	0.316	0.399
• at 150 Hz 500/690 V	kW	0.287	0.335	0.372	0.48
Power connection, input and output sides		Hole for M10	Hole for M10	Hole for M10	Hole for M10
• Conductor cross-section, max. (IEC)		Provided for busbar connection	Provided for busbar connection	Provided for busbar connection	Provided for busbar connection
DC link connection, DCPS, DCNS		Threaded socket M8	Threaded socket M8	Hole for M8	Hole for M8
• Conductor cross-section, max. (IEC)	mm ²	16	16	25	25
PE/GND connection		Threaded socket M6	Threaded socket M6	Threaded socket M6	Threaded socket M6
Cable length, max. between dv/dt filter and motor					
• shielded	m	100	100	100	100
• unshielded	m	150	150	150	150
Degree of protection		IP00	IP00	IP00	IP00
Dimensions					
• Width	mm	310	310	350	350
• Height	mm	283	283	317	317
• Depth	mm	238	238	260	260
Weight, approx.	kg	34	36	51	6
Approvals, acc. to		UL CSA (available soon)	UL CSA (available soon)	UL CSA (available soon)	UL CSA (available soon)
Suitable for Power Module					
• 500 ... 600 V 3 AC		-	-	6SL3310-1GF31-8AA3 (110 kW) 6SL3310-1GF32-2AA3 (132 kW)	6SL3310-1GF32-6AA3 (160 kW) 6SL3310-1GF33-3AA3 (200 kW)
• 660 ... 690 V 3 AC		6SL3310-1GH28-5AA3 (75 kW) 6SL3310-1GH31-0AA3 (90 kW)	6SL3310-1GH31-2AA3 (110 kW) 6SL3310-1GH31-5AA3 (132 kW)	6SL3310-1GH31-8AA3 (160 kW) 6SL3310-1GH32-2AA3 (200 kW)	6SL3310-1GH32-6AA3 (250 kW) 6SL3310-1GH33-3AA3 (315 kW)

SINAMICS G130

Drive converter chassis units

Load-side power components
dv/dt filters compact plus VPL

Technical data (continued)

Line voltage 500 ... 690 V 3 AC		dv/dt filter compact plus VPL		
		6SL3000-2DG34-1EA0	6SL3000-2DG35-8EA0	6SL3000-2DG38-1EA0
Rated current	A	410	575	810
I_{thmax}	A	410	575	810
Power loss, max.				
• at 50 Hz 500/690 V	kW	0.55	0.571	Reactor: 0.88 VPL: 0.084 Total: 0.964
• at 60 Hz 575 V	kW	0.568	0.586	Reactor: 0.918 VPL: 0.08 Total: 0.998
• at 150 Hz 500/690 V	kW	0.678	0.689	Reactor: 1.37 VPL: 0.059 Total: 1.196
Power connection, input and output sides		Hole for M12	Hole for M12	2 x elongated hole, 14x18 mm
• Conductor cross-section, max. (IEC)		Provided for busbar connection	Provided for busbar connection	Provided for busbar connection
DC link connection, DCPS, DCNS		Hole for M8	Hole for M8	Hole for M8
• Conductor cross-section, max. (IEC)		mm ² 50	50	95
PE/GND connection		Threaded socket M6	Threaded socket M6	Threaded socket M6 (reactor and VPL)
Cable length, max. between dv/dt filter and motor				
• shielded	m	100	100	100
• unshielded	m	150	150	150
Degree of protection		IP00	IP00	IP00
Dimensions				
• Width	mm	440	440	Reactor: 430 VPL: 277
• Height	mm	369	369	Reactor: 385 VPL: 360
• Depth	mm	311	311	Reactor: 323 VPL: 291
Weight, approx.	kg	87	100	Reactor: 171.2 VPL: 18.8 Total: 190
Approvals, acc. to		UL CSA (available soon)	UL CSA (available soon)	UL CSA (available soon)
Suitable for Power Module				
• 500 ... 600 V 3 AC		6SL3310-1GF34-1AA3 (250 kW)	6SL3310-1GF34-7AA3 (315 kW) 6SL3310-1GF35-8AA3 (400 kW)	6SL3310-1GF37-4AA3 (500 kW) 6SL3310-1GF38-1AA3 (560 kW)
• 660 ... 690 V 3 AC		6SL3310-1GH34-1AA3 (400 kW)	6SL3310-1GH34-7AA3 (450 kW) 6SL3310-1GH35-8AA3 (560 kW)	6SL3310-1GH37-4AA3 (710 kW) 6SL3310-1GH38-1AA3 (800 kW)

SINAMICS G130

Drive converter chassis units

Load-side power components Sine-wave filters

Overview



Sine-wave filters are available in the voltage range 380 V to 480 V up to a power rating of 250 kW – and in the voltage range 500 V to 600 V – up to a type rating of 132 kW.

The sine-wave filter at the converter output supplies almost perfect sinusoidal voltages on the motor so that standard motors can be used without special cables or power derating. Standard cables can be used. The maximum permissible motor feeder cable length is 300 m. The maximum output frequency is 150 Hz (380 V up to 480 V) or 115 Hz (500 V up to 600 V).

Note:

The pulse frequency of the converter must be increased when a sine-wave filter is used. This reduces the power available at the drive converter output (for the derating factor, refer to the SINAMICS Low Voltage Engineering Manual). The modulation depth of the output voltage decreases to approx. 85 % (380 V to 480 V) or approx. 83 % (500 V to 600 V). It should be noted that the reduced voltage at the motor terminals compared to the rated motor voltage means that the motor reaches the field weakening range earlier.

It is only permissible to operate the sine-wave filter when the motor is connected! (Sine-wave filters are not no-load proof).

The SINAMICS Low Voltage Engineering Manual contains additional information about sine-wave filters, which is available as a PDF file on the CD-ROM included with the catalog.

Selection and ordering data

Suitable for Power Module	Type rating of the Power Module at 400 V or 500 V	Sine-wave filter
Type	kW	Order No.
380 ... 480 V 3 AC		
6SL3310-1GE32-1AA3	110	6SL3000-2CE32-3AA0
6SL3310-1GE32-6AA3	132	
6SL3310-1GE33-1AA3	160	6SL3000-2CE32-8AA0
6SL3310-1GE33-8AA3	200	6SL3000-2CE33-3AA0
6SL3310-1GE35-0AA3	250	6SL3000-2CE34-1AA0
500 ... 600 V 3 AC		
6SL3310-1GF31-8AA3	110	6SL3000-2CF31-7AA0
6SL3310-1GF32-2AA3	132	

SINAMICS G130

Drive converter chassis units

Load-side power components
Sine-wave filters

Technical data

Line voltage 380 ... 480 V 3 AC		Sine-wave filter			
		6SL3000-2CE32-3AA0	6SL3000-2CE32-8AA0	6SL3000-2CE33-3AA0	6SL3000-2CE34-1AA0
Rated current	A	225	276	333	408
Power loss	kW	0.6	0.69	0.53	0.7
Connections					
• Load		1 hole for M10	1 hole for M10	1 hole for M10	1 hole for M10
• PE		1 hole for M10	1 hole for M10	1 hole for M10	1 hole for M10
Max. cable length between sine-wave filter and motor					
• shielded	m	300	300	300	300
• unshielded	m	450	450	450	450
Degree of protection		IP00	IP00	IP00	IP00
Dimensions					
• Width	mm	620	620	620	620
• Height	mm	300	300	370	370
• Depth	mm	320	320	360	360
Weight, approx.	kg	124	127	136	198
Conformity		CE	CE	CE	CE
Approvals, acc. to		cURus	cURus	cURus	cURus
Suitable for Power Module		6SL3310-1GE32-1AA3 (110 kW) 6SL3310-1GE32-6AA3 (132 kW)	6SL3310-1GE33-1AA3 (160 kW)	6SL3310-1GE33-8AA3 (200 kW)	6SL3310-1GE35-0AA3 (250 kW)

Line voltage 500 ... 600 V 3 AC		Sine-wave filter
		6SL3000-2CF31-7AA0
Rated current	A	188
Power loss	kW	0.8
Connections		
• Load		1 hole for M10
• PE		1 hole for M10
Max. cable length between motor reactor and motor		
• shielded	m	300
• unshielded	m	450
Degree of protection		IP00
Dimensions		
• Width	mm	620
• Height	mm	370
• Depth	mm	360
Weight, approx.	kg	210
Conformity		CE
Approvals, acc. to		cURus
Suitable for Power Module		6SL3310-1GF31-8AA3 (110 kW) 6SL3310-1GF32-2AA3 (132 kW)

SINAMICS G130

Drive converter chassis units

Control Unit Kit CU320-2 DP (PROFIBUS)

Overview



The communication, open-loop and closed-loop control functions for the chassis units are executed in the CU320-2 DP Control Unit.

The Control Unit Kit, which consists of the CU320-2 DP Control Unit and the drive software installed on the CompactFlash card, provides predefined interfaces that simplify configuring and commissioning. The CompactFlash card is plugged into the CU320-2 DP, and can be quickly replaced in order to upgrade the software.

Design

The CU320-2 DP Control Unit features the following connections and interfaces as standard:

- 4 DRIVE-CLiQ sockets for communication with other DRIVE-CLiQ devices, e.g. chassis units or Terminal Modules
- 1 PROFIBUS interface with PROFIdrive profile
- 12 parameterizable digital inputs (floating)
- 8 parameterizable bidirectional digital inputs/digital outputs (non-floating)
- 1 serial RS232 interface
- 1 interface for the BOP20 Basic Operator Panel
- 1 slot for the CompactFlash card on which firmware and parameters are stored
- 1 slot to install an option module for the interface extension
- 2 rotary coding switches for manually setting the PROFIBUS address
- 1 Ethernet interface for commissioning and diagnostics
- 3 test sockets and one reference ground for commissioning support
- 1 connection for the electronics power supply via the 24 V DC supply connector
- 1 PE/protective conductor connection
- 1 ground connection

A shield support for the signal cable shield on the option module is located on the CU320-2 DP Control Unit.

The available option slot is used to expand the interfaces, for example, to include additional terminals.

The status of the CU320-2 DP Control Unit is indicated via multi-color LEDs.

Selection and ordering data

Description	Order No.
Control Unit Kit PROFIBUS DP	6SL3040-1GA00-1AA0
consisting of:	
• Control Unit CU320-2 DP	
• CompactFlash card with the latest firmware	
• Equipment documentation on CD	
• STARTER commissioning tool on DVD	

Accessories

Description	Order No.
PROFIBUS connector without PG/PC connection	6ES7972-0BA42-0XA0
PROFIBUS connector with PG/PC connection	6ES7972-0BB42-0XA0
Dust-proof blanking plugs (50 units) for closing unused DRIVE-CLiQ ports	6SL3066-4CA00-0AA0

The SINAMICS Low Voltage Engineering Manual contains additional information about the CU320-2 DP Control Unit, which is available as a PDF file on the CD-ROM included with Catalog D 11.

SINAMICS G130

Drive converter chassis units

Control Unit Kit CU320-2 DP (PROFIBUS)

Integration

A CU320-2 DP Control Unit communicates with the components connected to it via DRIVE-CLiQ.

A CU320-2 DP Control Unit communicates with the higher-level control system using PROFIBUS and the PROFdrive profile.

A DRIVE-CLiQ cable to connect the CU320-2 DP to the SINAMICS G130 converter is included in the scope of supply of the Power Modules.

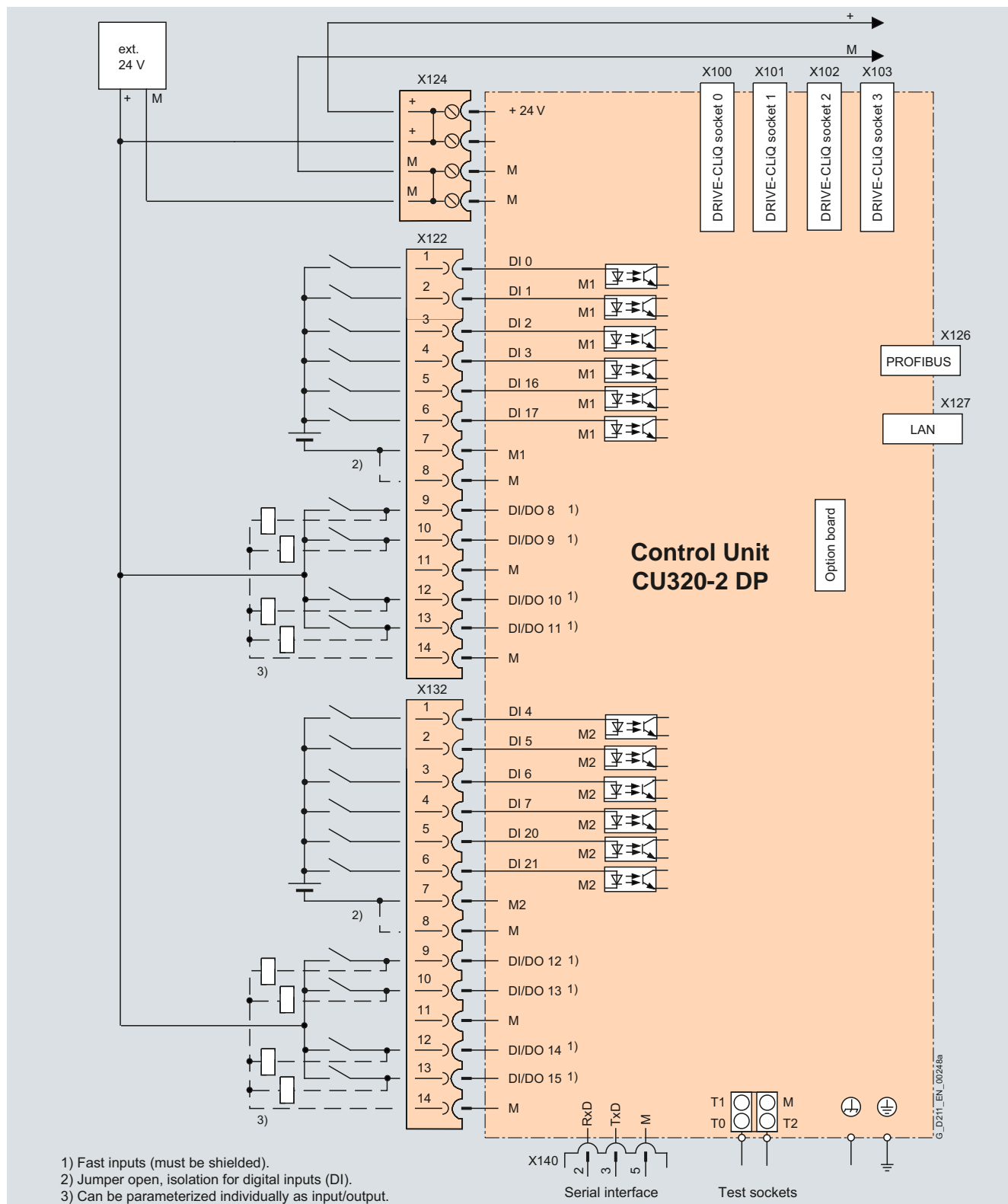

CU320-2 DP Control Unit connection diagram

SINAMICS G130

Drive converter chassis units

Control Unit Kit CU320-2 DP (PROFIBUS)

Technical data

Control Unit CU320-2 DP

Current requirement, max. at 24 V DC, typ. without taking into account digital outputs, expansion option slot and DRIVE-CLiQ supply	1.0 A
<ul style="list-style-type: none"> • Conductor cross-section, max. • Fuse protection, max. 	2.5 mm ² 20 A
Digital inputs in accordance with IEC 61131-2 type 1	12 floating digital inputs 8 bidirectional, non-floating digital inputs/outputs
<ul style="list-style-type: none"> • Voltage • Low level (an open digital input is interpreted as "low") • High level • Current consumption at 24 V DC, typ. • Delay time of the digital inputs, approx. ¹⁾ <ul style="list-style-type: none"> - L → H - H → L • Delay time of the fast digital inputs, approx. ¹⁾ <ul style="list-style-type: none"> - L → H - H → L • Conductor cross-section, max. 	-3 V ... +30 V -3 V ... +5 V 15 V ... 30 V 9 mA 50 μs 100 μs 5 μs 50 μs 1.5 mm ²
Digital outputs (continuously short-circuit-proof)	8 bidirectional non-floating digital inputs/outputs
<ul style="list-style-type: none"> • Voltage • Load current per digital output, max. • Delay time, typ. / max. <ul style="list-style-type: none"> - L → H - H → L • Conductor cross-section, max. 	24 V DC 500 mA 150 μs / 400 μs 75 μs / 100 μs 1.5 mm ²
Power loss	24 W
PE connection	M5 screw
Ground connection	M5 screw
Dimensions	
<ul style="list-style-type: none"> • Width • Height • Depth 	50 mm 300 mm 226 mm
Weight, approx.	2.3 kg
Approvals, acc. to	cULus

¹⁾ The specified delay times refer to the hardware. The actual reaction time depends on the time slice in which the digital input or output is processed.

SINAMICS G130

Drive converter chassis units

Control Unit Kit CU320-2 PN (PROFINET)

Overview



The communication, open-loop and closed-loop control functions for the chassis units are executed in the CU320-2 PN Control Unit.

The Control Unit Kit, which consists of the CU320-2 PN Control Unit and the drive software installed on the CompactFlash card, provides predefined interfaces that simplify configuring and commissioning. The CompactFlash card is plugged into the CU320-2 PN and can be quickly replaced in order to upgrade the software.

Design

The CU320-2 PN Control Unit features the following connections and interfaces as standard:

- 4 DRIVE-CLiQ sockets for communication with other DRIVE-CLiQ devices, e.g. chassis units or Terminal Modules
- 2 PROFINET interface with PROFIdrive profile
- 12 parameterizable digital inputs (floating)
- 8 parameterizable bidirectional digital inputs/outputs (non-floating)
- 1 serial RS232 interface
- 1 interface for the BOP20 Basic Operator Panel
- 1 slot for the CompactFlash Card on which firmware and parameters are stored
- 1 slot to install an option module for the interface extension
- 1 Ethernet interface for commissioning and diagnostics
- 3 test sockets and one reference ground for commissioning support
- 1 connection for the electronics power supply via the 24 V DC supply connector
- 1 PE/protective conductor connection
- 1 ground connection

A shield support for the signal cable shield on the option module is located on the CU320-2 PN Control Unit.

The available option slot is used to expand the interfaces, for example, to include additional terminals.

The status of the CU320-2 PN Control Unit is indicated using multi-color LEDs.

Selection and ordering data

Description	Order No.
Control Unit Kit PROFINET PN	6SL3040-1GA01-1AA0
consisting of:	
• Control Unit CU320-2 PN	
• CompactFlash card with the latest firmware	
• Equipment documentation on CD	
• STARTER commissioning tool on DVD	

Accessories

Description	Order No.
Industrial Ethernet FC	
• RJ45 Plug 145 (1 unit)	6GK1901-1BB30-0AA0
• RJ45 Plug 145 (10 units)	6GK1901-1BB30-0AB0
• Stripping tool	6GK1901-1GA00
• Standard cable GP 2x2	6XV1840-2AH10
• Flexible cable GP 2x2	6XV1870-2B
• Trailing cable GP 2x2	6XV1870-2D
• Trailing cable 2x2	6XV1840-3AH10
• Marine cable 2x2	6XV1840-4AH10
Dust-proof blanking plugs	6SL3066-4CA00-0AA0
(50 units) for closing unused DRIVE-CLiQ ports	

The SINAMICS Low Voltage Engineering Manual contains additional information about the CU320-2 PN Control Unit, which is available as a PDF file on the CD-ROM included with Catalog D 11.

SINAMICS G130

Drive converter chassis units

Control Unit Kit CU320-2 PN (PROFINET)

Integration

A CU320-2 PN Control Unit communicates with the components connected to it via DRIVE-CLiQ.

A CU320-2 PN Control Unit communicates with the higher-level control system using PROFINET and the PROFIdrive profile.

A DRIVE-CLiQ cable to connect the CU320-2 PN to the SINAMICS G130 converter is included in the scope of supply of the Power Modules.

2

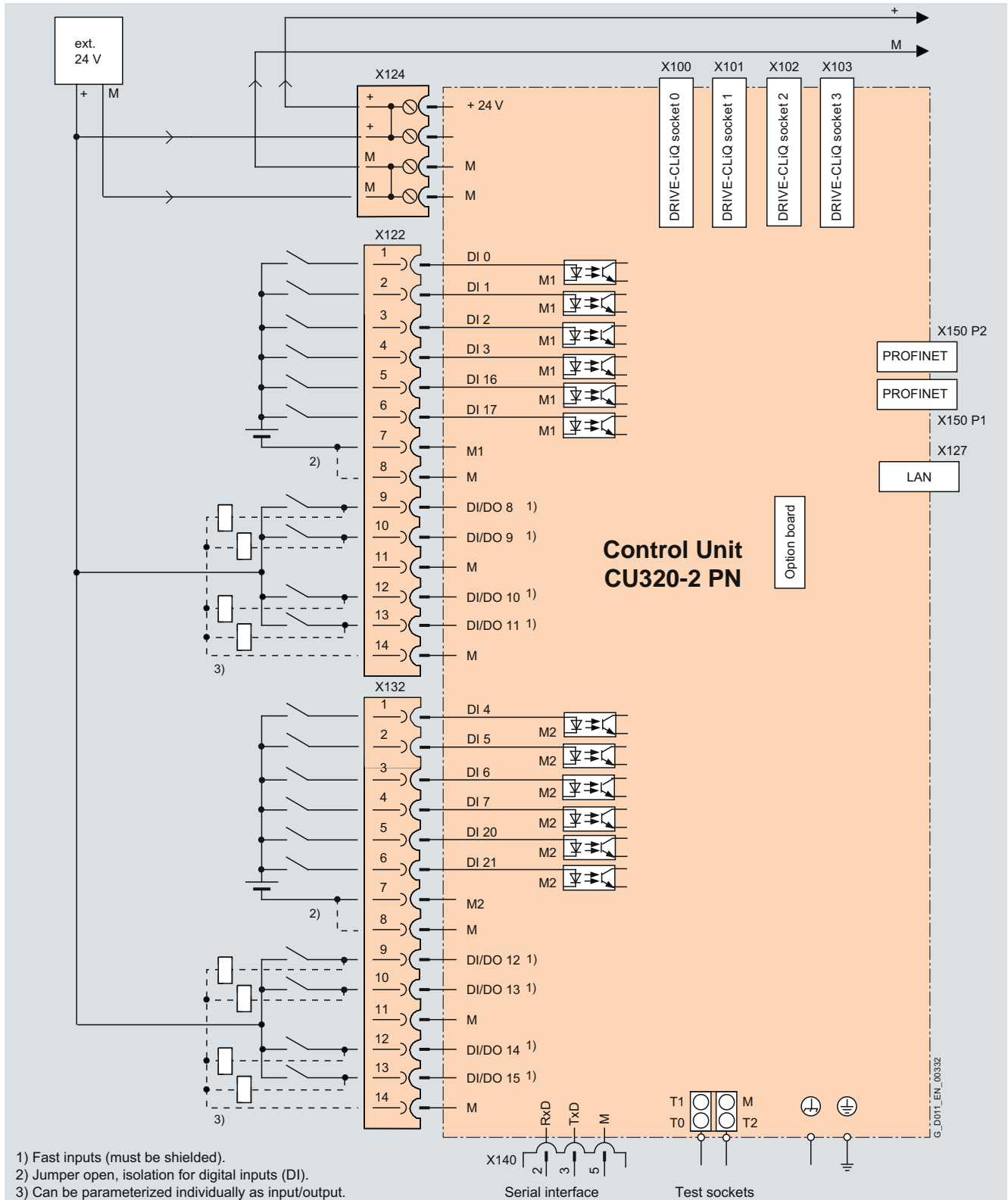

Connection diagram, Control Unit CU320-2 PN

Technical data

Control Unit CU320-2 PN

Current requirement, max. at 24 V DC, typ. without taking into account digital outputs, expansion option slot and DRIVE-CLiQ supply	1.0 A
• Conductor cross-section, max.	2.5 mm ²
• Fuse protection, max.	20 A
Digital inputs in accordance with IEC 61131-2 type 1	12 floating digital inputs 8 bidirectional, non-floating digital inputs/outputs
• Voltage	-3 V ... +30 V
• Low level (an open digital input is interpreted as "low")	-3 V ... +5 V
• High level	15 V ... 30 V
• Current consumption at 24 V DC, typ.	9 mA
• Delay time of the digital inputs, approx. ¹⁾	
- L → H	50 μs
- H → L	100 μs
• Delay time of the fast digital inputs, approx. ¹⁾	
- L → H	5 μs
- H → L	50 μs
• Conductor cross-section, max.	1.5 mm ²
Digital outputs (continuously short-circuit-proof)	8 bidirectional non-floating digital inputs/outputs
• Voltage	24 V DC
• Load current per digital output, max.	500 mA
• Delay time, typ. / max.	
- L → H	150 μs / 400 μs
- H → L	75 μs / 100 μs
• Conductor cross-section, max.	1.5 mm ²
Power loss	24 W
PE connection	M5 screw
Ground connection	M5 screw
Dimensions	
• Width	50 mm
• Height	300 mm
• Depth	226 mm
Weight, approx.	2.3 kg
Approvals, acc. to	cULus

¹⁾ The specified delay times refer to the hardware. The actual reaction time depends on the time slice in which the digital input or output is processed.

SINAMICS G130

Drive converter chassis units

Supplementary system components BOP20 Basic Operator Panel

Overview



BOP20 Basic Operator Panel

The BOP20 Basic Operator Panel can be plugged into the CU320-2 Control Unit and may be used to acknowledge faults, set parameters and read diagnostic information (e.g. alarms and fault messages).

Design

The BOP20 Basic Operator Panel has a backlit two-line display area and 6 keys.

The integrated plug connector at the rear of the BOP20 Basic Operator Panel is used to connect power to the BOP20 and establish communication with the CU320-2 Control Unit.

Integration



CU320-2 Control Unit with inserted BOP20 Basic Operator Panel

Selection and ordering data

Description	Order No.
BOP20 Basic Operator Panel	6SL3055-0AA00-4BA0

SINAMICS G130

Drive converter chassis units

Supplementary system components

AOP30 Advanced Operator Panel

Overview



The user-friendly AOP30 operator panel is an optional input/output device for SINAMICS G130 converters. For SINAMICS G150 drive converter cabinet units, it is fitted in the cabinet door as standard. It can be ordered separately for a SINAMICS G130 converter.

It has the following features and characteristics:

- Graphical LCD display with backlighting for plain text display and a bar display of process variables
- LEDs for display of operating modes
- Help function describing causes of and remedies for faults and alarms
- Keypad for operational control of a drive
- Local/remote switchover for selecting the input point (priority assigned to operator panel or customer Terminal Module/communications channel)
- Numeric keypad for input of setpoint or parameter values
- Function keys for prompted navigation in the menu
- Two-stage safety strategy to protect against accidental or unauthorized changes to settings.
 - Operation of the drive from the operator panel can be disabled by the keyboard lock so that only parameter values and process variables can be displayed on the operating panel.
 - A password can be used to prevent the unauthorized modification of converter parameters.
- Front panel with degree of protection IP55

The AOP30 communicates with the SINAMICS drive via the serial RS232 interface and PPI protocol.

The AOP30 may be omitted if the drive is only operated via PROFIBUS, for example, and no local display is required on the cabinet. The AOP30 can then be used simply for commissioning purposes and to obtain diagnostic information, in which case, it is plugged into the RS232 interface on the CU320-2 Control Unit.

An external 24 V power supply (max. power consumption 200 mA) is needed to operate the AOP30. This can be tapped from the Power Module supply.

AOP30
X540

9-pole SUB-D
RxD 2
TxD 3
M 0V 5

CU320-2
X140

9-pole SUB-D
RxD 2
TxD 3
M 0V 5

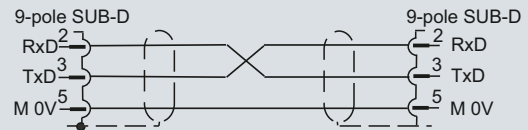

G_D011_EN_00068

Assignment of the serial plug-in cable

Design

The AOP30 is an operator panel with graphical display and membrane keyboard. The device can be installed in a cabinet door (thickness: between 2 mm and 4 mm).

Features:

- Display with green backlighting, resolution 240 x 64 pixels
- 26-key membrane keyboard
- Connection for a 24 V power supply
- RS232 interface to the CU320-2
- Time and date memory with internal battery backup
- 4 LEDs to signal the operating state of the drive:
 - RUN green
 - ALARM yellow
 - FAULT red
 - Local/Remote green

Function

The current operating states, setpoints and actual values, parameters, indices, faults and alarms are displayed on the display panel.

English, German, French, Italian, Spanish and **Chinese** are stored on the CU320-2 Control Unit's CompactFlash card as operator panel languages. The desired language must be downloaded to the AOP30 prior to commissioning. **Russian, Polish** and **Czech** are available in addition to these standard panel languages. These can be downloaded free of charge from the Internet under the following link:
<http://support.automation.siemens.com/>

Selection and ordering data

Description	Order No.
AOP30 Advanced Operator Panel	6SL3055-0AA00-4CA4

Accessories

RS232 plug-in cable for connecting the AOP30 to the CU320-2	Length m	Order No.
	1	6FX8002-1AA01-1AB0
	2	6FX8002-1AA01-1AC0
	3	6FX8002-1AA01-1AD0
	4	6FX8002-1AA01-1AE0
	5	6FX8002-1AA01-1AF0
	6	6FX8002-1AA01-1AG0
	7	6FX8002-1AA01-1AH0
	8	6FX8002-1AA01-1AJ0
	9	6FX8002-1AA01-1AK0
	10	6FX8002-1AA01-1BA0

SINAMICS G130

Drive converter chassis units

Supplementary system components AOP30 Advanced Operator Panel

Technical data

AOP30 Advanced Operator Panel	
Power supply	24 V DC (20.4 V ... 28.8 V)
Current requirement	
• Without backlighting	< 100 mA
• For max. backlighting	< 200 mA
Data interface	RS232/RS485 interface, PPI protocol
Backup battery	3 V lithium CR2032
Operating temperature	0 ... 55 °C
Storage and transport temperature	-25 ... +70 °C
Degree of protection	IP20 from the inside of the cabinet IP55 from the outside of the cabinet
Dimensions	
• Width	212 mm
• Height	156 mm
• Depth	31 mm
Weight	0.55 kg
Approvals, acc. to	cULus, CE

SINAMICS G130

Drive converter chassis units

Supplementary system components CBC10 Communication Board

Overview



The CBC10 Communication Board is used to interface the CU320-2 Control Unit to the CAN (Controller Area Network) protocol. The board's driver software fulfills the standards of the following CANopen specification of the CiA organization (CAN in Automation):

- Communication profiles in accordance with DS 301
- Drive profile in accordance with DSP 402 (in this case Profile Velocity Mode)
- EDS (Electronic Data Sheet) in accordance with DSP 306
- Operational status signaling in accordance with DSP 305

Design

The CBC10 Communication Board plugs into the option slot on the CU320-2 Control Unit. The CAN interface on the CBC10 has 2 SUB-D connections for input and output.

Technical data

CBC10 Communication Board

Current requirement, max. at 24 V DC via CU320-2 Control Unit	0.05 A
Power loss	< 3 W
Weight, approx.	0.1 kg
Approvals, acc. to	cULus

Selection and ordering data

Description	Order No.
CBC10 Communication Board	6SL3055-0AA00-2CA0

Accessories

Description	Order No.
SUB-D connector , 9-pin, socket (3 units)	6FC9341-2AE
SUB-D connector , 9-pin, plug connector (3 units)	6FC9341-2AF

SINAMICS G130

Drive converter chassis units

Supplementary system components CBE20 Communication Board

Overview



The CBE20 Communication Board is required, if

- a SINAMICS G130 or G150 converter, equipped with a Control Unit CU320-2 DP (PROFIBUS), is to be connected to a PROFINET-IO network,
- SINAMICS Link is to be used to directly exchange data between several Control Units CU320-2 DP (PROFIBUS) or CU320-2 PN (PROFINET) without using a higher-level control system.

With the CBE20 Communication Board, SINAMICS G130 or G150 then assumes the function of a PROFINET IO device in the sense of PROFINET and can perform the following functions:

- PROFINET IO device
- 100 Mbit/s full duplex
- Supports real-time classes of PROFINET IO:
 - RT (Real-Time)
 - IRT (Isochronous Real-Time), minimum send cycle 500 μ s
- Connects to controls as a PROFINET IO device according to the PROFIdrive profile
- Standard TCP/IP communication for engineering processes using the STARTER commissioning tool
- Integrated 4-port switch with four RJ45 sockets based on the PROFINET ASIC ERTEC400. The optimum topology (line, star, tree) can therefore be configured without additional external switches.

SINAMICS Link

SINAMICS Link can be used to directly exchange data between several Control Units CU320-2 DP (PROFIBUS) or CU320-2 PN (PROFINET) without using a higher-level control system. In this case, the Communication Board CBE20 is required. Potential applications for the SINAMICS Link are:

- Torque distribution with multiple drive systems
- Setpoint cascading with multiple drive systems
- Load distribution on drives coupled by material
- Couplings between SINAMICS G or SINAMICS S with CU320-2 and SINAMICS DC Master with CUD.

Nodes other than the SINAMICS CU320-2 Control Units or the CUD Control Units of the SINAMICS DC Master cannot be linked into this communication network.

SINAMICS Link is activated by appropriately parameterizing the Control Units of the participants.

Integration

The CBE20 Communication Board plugs into the option slot on the CU320-2 Control Unit.

Technical data

CBE20 Communication Board	
Current requirement at 24 V DC	0.16 A
Ambient temperature, permissible	
• Storage and transport	-40 ... +70 °C
• Operation	0 ... 55 °C
Dimensions	130 mm × 78 mm
Weight, approx.	76 g
Approvals, acc. to	cULus

Selection and ordering data

Description	Order No.
CBE20 Communication Board	6SL3055-0AA00-2EB0

Accessories

Description	Order No.
Industrial Ethernet FC	
• RJ45 Plug 145 (1 unit)	6GK1901-1BB30-0AA0
• RJ45 Plug 145 (10 units)	6GK1901-1BB30-0AB0
• Stripping tool	6GK1901-1GA00
• Standard cable GP 2x2	6XV1840-2AH10
• Flexible cable GP 2x2	6XV1870-2B
• Trailing cable GP 2x2	6XV1870-2D
• Trailing cable 2x2	6XV1840-3AH10
• Marine cable 2x2	6XV1840-4AH10

For further information about connectors and cables, refer to Catalog IK PI.

SINAMICS G130

Drive converter chassis units

Supplementary system components TB30 Terminal Board

Overview



The TB30 Terminal Board supports the addition of digital inputs/digital outputs and analog inputs/analog outputs to the CU320-2 Control Unit.

Design

The following are located on the TB30 Terminal Board:

- Power supply for digital inputs/digital outputs
- 4 digital inputs
- 4 digital outputs
- 2 analog inputs
- 2 analog outputs

The TB30 Terminal Board plugs into the option slot on a Control Unit.

A shield support for the signal cable shield is located on the CU320-2 Control Unit.

Selection and ordering data

Description	Order No.
TB30 Terminal Board	6SL3055-0AA00-2TA0

Technical data

TB30 Terminal Board

Current requirement, max. at 24 V DC via the CU320-2 Control Unit without taking into account the digital outputs	0.05 A
• Conductor cross-section, max.	2.5 mm ²
• Fuse protection, max.	20 A
Digital inputs in accordance with IEC 61131-2 type 1	
• Voltage	-3 ... +30 V
• Low level (an open digital input is interpreted as "low")	-3 ... +5 V
• High level	15 ... 30 V
• Current consumption at 24 V DC, typ.	10 mA
• Delay time of digital inputs ¹⁾ , approx.	
- L → H	50 μs
- H → L	100 μs
• Conductor cross-section, max.	0.5 mm ²
Digital outputs (continuously short-circuit-proof)	
• Voltage	24 V DC
• Load current per digital output, max.	500 mA
• Delay time of digital outputs ¹⁾ , approx.	150 μs
• Conductor cross-section, max.	0.5 mm ²
Analog inputs (difference)	
• Voltage range (an open analog input is interpreted as 0 V)	-10 ... +10 V
• Internal resistance R_i	65 kΩ
• Resolution ²⁾	13 bits + sign
• Conductor cross-section, max.	0.5 mm ²
Analog outputs (continuously short-circuit-proof)	
• Voltage range	-10 ... +10 V
• Load current, max.	-3 ... +3 mA
• Resolution	11 bits + sign
• Settling time, approx.	200 μs
• Conductor cross-section, max.	0.5 mm ²
Power loss	< 3 W
Weight, approx.	0.1 kg
Approvals, acc. to	cULus

¹⁾ The specified delay times refer to the hardware. The actual reaction time depends on the time slice in which the digital input/output is processed.

²⁾ If the analog input is to be operated in the signal processing sense with continuously variable input voltage, the sampling frequency $f_a = 1/t_{\text{time slice}}$ must be at least twice the value of the highest signal frequency f_{max} .

SINAMICS G130

Drive converter chassis units

Supplementary system components TB30 Terminal Board

Integration

2

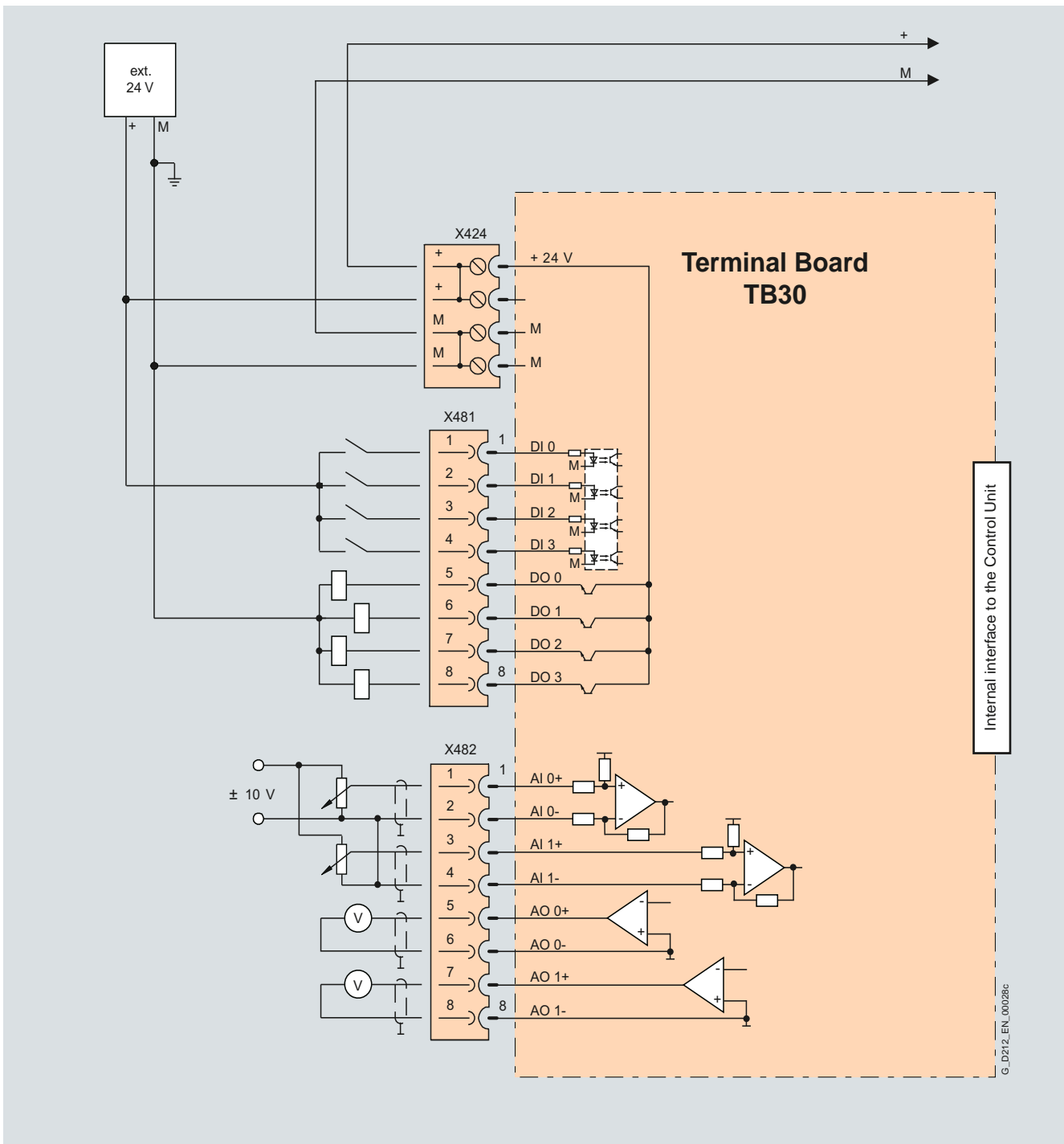

Typical connection of TB30 Terminal Board

Overview



The TM31 Terminal Module can be used to increase the number of available digital inputs and outputs and the number of analog input and outputs within a drive system.

The TM31 Terminal Module also features relay outputs with changeover contact and a temperature sensor input.

Design

The following are located on the TM31 Terminal Module:

- 8 digital inputs
- 4 bidirectional digital inputs/outputs
- 2 relay outputs with changeover contact
- 2 analog inputs
- 2 analog outputs
- 1 temperature sensor input (KTY84-130 or PTC)
- 2 DRIVE-CLiQ sockets
- 1 connection for the electronics power supply via the 24 V DC supply connector
- 1 PE/protective conductor connection

The TM31 Terminal Module can be snapped onto a TH 35 mounting rail to EN 60715 (IEC 60715).

The signal cable shield can be connected to the TM31 Terminal Module via a shield connection terminal, e.g. Phoenix Contact type SK8 or Weidmüller type KLBÜ CO 1. The shield connection terminal must not be used for strain relief.

The status of the TM31 Terminal Module is indicated via a multi-color LED.

Selection and ordering data

Description	Order No.
TM31 Terminal Module (without DRIVE-CLiQ cable)	6SL3055-0AA00-3AA1

SINAMICS G130

Drive converter chassis units

Supplementary system components TM31 Terminal Module

Technical data

TM31 Terminal Module	
Current requirement, max. at 24 V DC, not taking into account the digital outputs	0.2 A
• Conductor cross-section, max.	2.5 mm ²
• Fuse protection, max.	20 A
Digital inputs in accordance with IEC 61131-2 type 1	
• Voltage	-3 ... +30 V
• Low level (an open digital input is interpreted as "low")	-3 ... +5 V
• High level	15 ... 30 V
• Current consumption at 24 V DC, typ.	10 mA
• Delay times of digital inputs ¹⁾ , approx.	
- L → H	50 μs
- H → L	100 μs
• Conductor cross-section, max.	1.5 mm ²
Digital outputs (continuously short-circuit-proof)	
• Voltage	24 V DC
• Load current per digital output, max.	100 mA
• Aggregate current of digital outputs, max.	400 mA
• Delay times of digital outputs ¹⁾	
- typ.	150 μs at 0.5 A resistive load
- max.	500 μs
• Conductor cross-section, max.	1.5 mm ²
Analog inputs (a switch is used to toggle between voltage and current input)	
• As voltage input	
- Voltage range	-10 ... +10 V
- Internal resistance R_i	100 kΩ
• As current input	
- Current range	4 ... 20 mA, -20 ... +20 mA, 0 ... 20 mA
- Internal resistance R_i	250 Ω
- Resolution ²⁾	11 bits + sign
• Conductor cross-section, max.	1.5 mm ²
Analog outputs (continuously short-circuit-proof)	
• Voltage range	-10 ... +10 V
• Load current, max.	-3 ... +3 mA
• Current range	4 ... 20 mA, -20 ... +20 mA, 0 ... 20 mA
• Load resistance, max.	500 Ω for outputs in the range -20 ... +20 mA
• Resolution	11 bits + sign
• Conductor cross-section, max.	1.5 mm ²

TM31 Terminal Module	
Relay outputs (changeover contacts)	
• Load current, max.	8 A
• Operating voltage, max.	250 V AC, 30 V DC
• Switching capacity, max.	
- at 250 V AC	2000 VA (cos φ = 1) 750 VA (cos φ = 0.4)
- at 30 V DC	240 W (resistive load)
• Required minimum current	100 mA
• Conductor cross-section, max.	2.5 mm ²
Power loss	< 5 W
PE connection	M4 screw
Dimensions	
• Width	50 mm
• Height	150 mm
• Depth	111 mm
Weight, approx.	0.87 kg
Approvals, acc. to	cULus

¹⁾ The specified delay times refer to the hardware. The actual reaction time depends on the time slice in which the digital input/output is processed.

²⁾ If the analog input is to be operated in the signal processing sense with continuously variable input voltage, the sampling frequency $f_a = 1/t_{\text{time slice}}$ must be at least twice the value of the highest signal frequency f_{max} .

Integration

The TM31 Terminal Module communicates with the CU320-2 Control Unit via DRIVE-CLiQ.

2

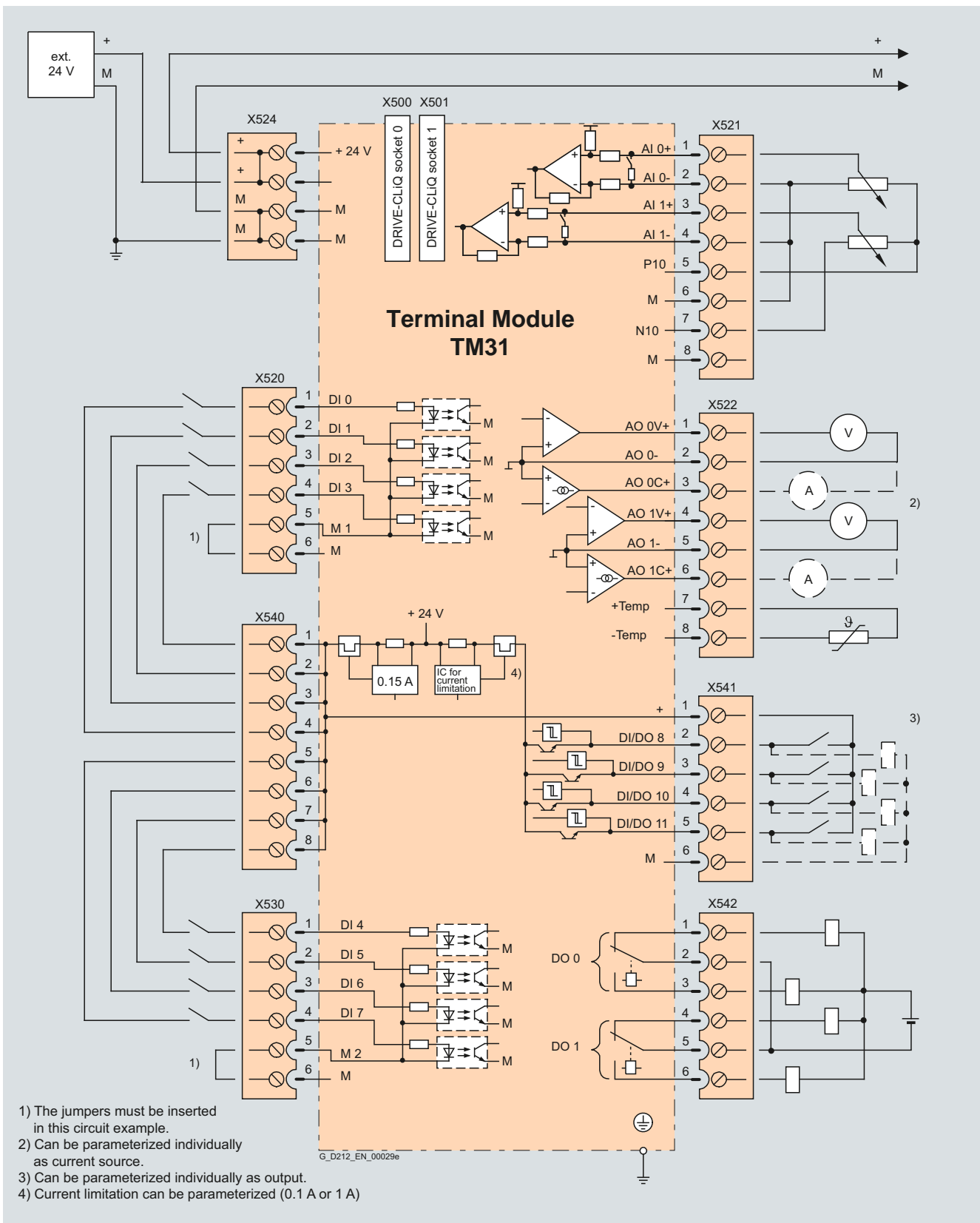

Typical connection of TM31 Terminal Module

SINAMICS G130

Drive converter chassis units

Supplementary system components VSM10 Voltage Sensing Module

Overview



The VSM10 Voltage Sensing Module reads the voltage waveshape at the motor end. This allows the SINAMICS G130 converter to be connected to a permanent-magnet, synchronous motor without encoder ("flying restart" function).

Design

The VSM10 Voltage Sensing Module has the following interfaces:

- 1 connection for direct voltage sensing up to 690 V
- 1 connection for voltage sensing using voltage transformers, maximum voltage 100 V
- 1 temperature sensor input (KTY84-130 or PTC)
- 1 DRIVE-CLiQ socket
- 1 connection for the electronics power supply via the 24 V DC supply connector
- 1 PE/protective conductor connection

The VSM10 Voltage Sensing Module can be snapped onto a TH 35 top-hat rail to EN 60715 (IEC 60715).

The status of the VSM10 Voltage Sensing Module is indicated by a two-color LED.

Technical data

VSM10 Voltage Sensing Module

Current requirement, max. at 24 V DC	0.2 A
• Conductor cross-section, max.	2.5 mm ²
Power loss, approx.	< 5 W
Voltage sensing	
• Input resistance	
- Terminal X521	> 362 kΩ/phase
- Terminal X522	> 2.5 MΩ/phase
2 analog inputs (reserved for monitoring an Active Interface Module in chassis format)	
• Internal resistance (between differential inputs)	approx. 100 kΩ
• Resolution	12 bit
PE connection	M4 screw at the housing
Dimensions	
• Width	50 mm
• Height	150 mm
• Depth	111 mm
Weight, approx.	0.9 kg
Approvals, acc. to	cULus

Selection and ordering data

Description	Order No.
VSM10 Voltage Sensing Module (without DRIVE-CLiQ cable)	6SL3053-0AA00-3AA0

Integration

The VSM10 Voltage Sensing Module communicates with the CU320-2 Control Unit via DRIVE-CLiQ.

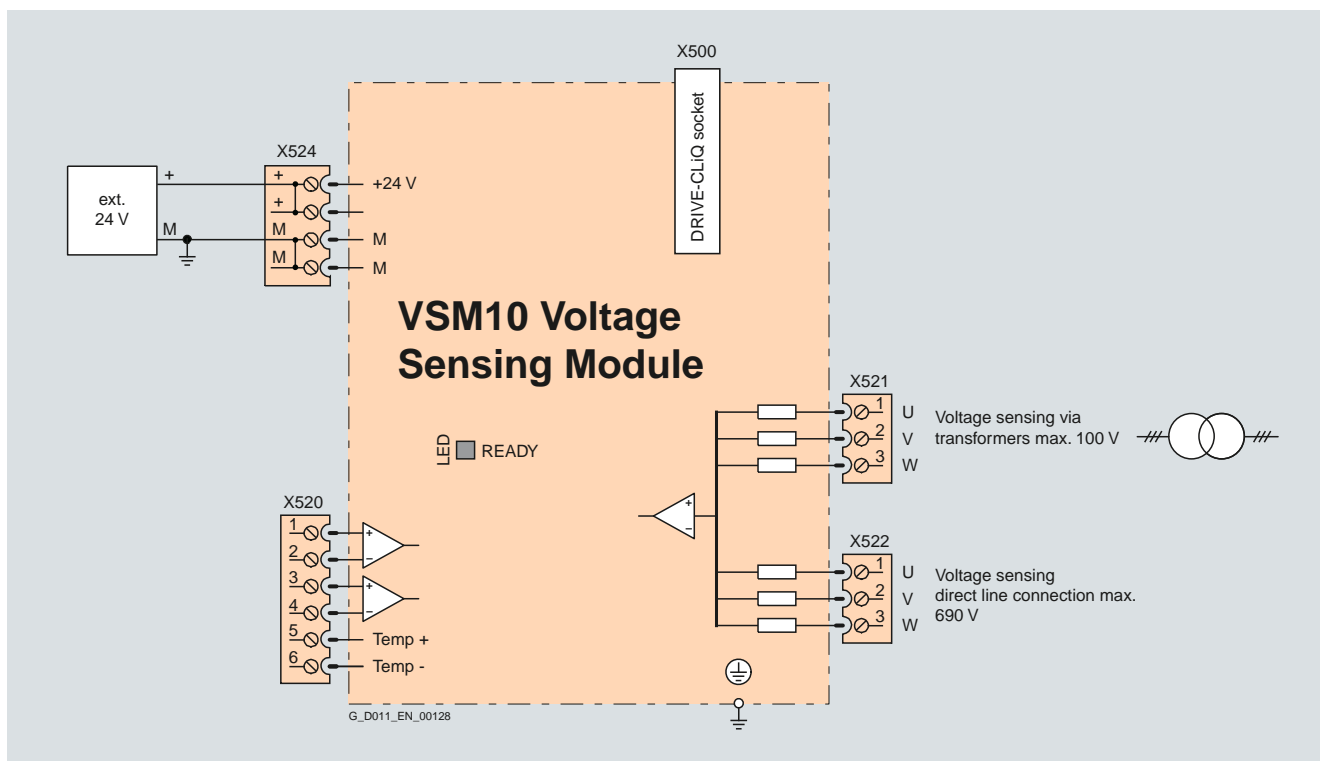

Typical connection of VSM10 Voltage Sensing Module

SINAMICS G130

Drive converter chassis units

Supplementary system components SMC30 Sensor Module Cabinet-Mounted

Overview



The SMC30 Sensor Module Cabinet-Mounted can be used to evaluate the encoders of motors without a DRIVE-CLiQ interface. External encoders can also be connected via the SMC30.

The following encoder signals can be evaluated:

- Incremental encoders TTL/HTL with and without open-circuit detection (open-circuit detection is only available with bipolar signals)
- SSI encoder with TTL/HTL incremental signals
- SSI encoder without incremental signals

The motor temperature can also be detected using KTY84-130 or PTC thermistors.

Design

The SMC30 Sensor Module Cabinet-Mounted features the following interfaces as standard:

- 1 DRIVE-CLiQ interface
- 1 encoder connection including motor temperature detection (KTY84-130 or PTC) via SUB-D connector or terminals
- 1 connection for the electronics power supply via the 24 V DC supply connector
- 1 PE/protective conductor connection

The status of the SMC30 Sensor Module Cabinet-Mounted is indicated via a multi-color LED.

The SMC30 Sensor Module Cabinet-Mounted can be snapped onto a TH 35 top-hat rail according to EN 60715 (IEC 60715).

The maximum encoder cable length between SMC30 modules and encoders is 100 m. For HTL encoders, this length can be increased to 300 m if the A+/A- and B+/B- signals are evaluated and the power supply cable has a minimum cross section of 0.5 mm².

The signal cable shield can be connected to the SMC30 Sensor Module Cabinet-Mounted via a shield connection terminal, e.g. Phoenix Contact type SK8 or Weidmüller type KLBÜ CO 1.

Integration

The SMC30 Sensor Module Cabinet-Mounted communicates with the CU320-2 Control Unit via DRIVE-CLiQ.

Technical data

SMC30 Sensor Module Cabinet-Mounted

Current requirement, max. at 24 V DC, not taking an encoder into account	0.2 A
• Conductor cross-section, max.	2.5 mm ²
• Fuse protection, max.	20 A
Power loss	< 10 W
Encoders which can be evaluated	<ul style="list-style-type: none"> • Incremental encoder TTL/HTL • SSI encoder with TTL/HTL incremental signals • SSI encoder without incremental signals
• Input impedance	
- TTL	576 Ohm
- HTL, max.	16 mA
• Encoder supply	24 V DC / 0.35 A or 5 V DC / 0.35 A
• Encoder frequency, max.	300 kHz
• SSI baud rate	100 ... 250 kBaud
• Limiting frequency	300 kHz
• Resolution absolute position SSI	30 bit
• Cable length, max.	
- TTL encoder	100 m (only bipolar signals permitted) ¹⁾
- HTL encoder	100 m for unipolar signals 300 m for bipolar signals ¹⁾
- SSI encoder	100 m
PE connection	M4 screw
Dimensions	
• Width	30 mm
• Height	150 mm
• Depth	111 mm
Weight, approx.	0.45 kg
Approvals, acc. to	cULus

Selection and ordering data

Description	Order No.
SMC30 Sensor Module Cabinet-Mounted (without DRIVE-CLiQ cable)	6SL3055-0AA00-5CA2

¹⁾ Signal cables twisted in pairs and shielded.

SINAMICS G130

Drive converter chassis units

MOTION-CONNECT connection system

Signal cables

2

Overview

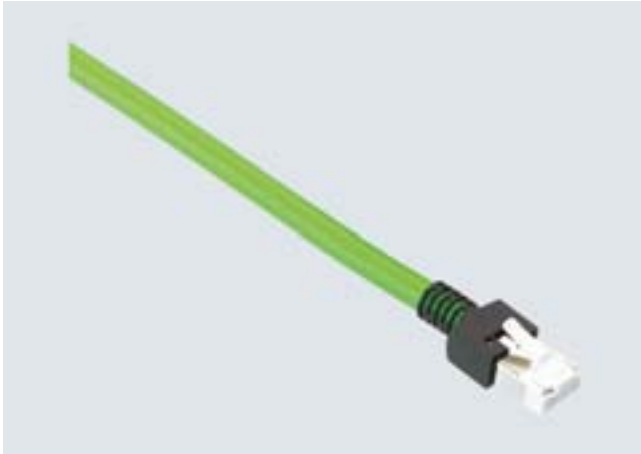

Communication between the CU320-2 Control Unit, the Power Module and other active SINAMICS components takes place via DRIVE-CLiQ, the drive's internal serial interface. Pre-assembled cables are available for this purpose.

MOTION-CONNECT DRIVE-CLiQ cables

Pre-assembled MOTION-CONNECT cables for DRIVE-CLiQ are available precut to length in order to connect the Control Units to the Power Modules and Terminals.

The DRIVE-CLiQ cable needed to connect the Power Module to the Control Unit is supplied as standard with the Power Module.

Application

The DRIVE-CLiQ cables are suitable only for wiring DRIVE-CLiQ components which have an external 24 V DC power supply.

Serial plug-in cable for connecting the AOP30 to the CU320-2

The AOP30 Advanced Operator Panel is connected to the CU320-2 Control Unit via a serial plug-in cable (RS232C cable).

The maximum cable length is 10 m. To guarantee disturbance-free communication, a shielded cable is recommended, and the cable shield should be connected to both connector housings.

Selection and ordering data

Signal cable	Length m	Order No.
Pre-assembled DRIVE-CLiQ cable	0.11	6SL3060-4AB00-0AA0
	0.16	6SL3060-4AD00-0AA0
Degree of protection of connector IP20/IP20	0.21	6SL3060-4AF00-0AA0
	0.26	6SL3060-4AH00-0AA0
	0.36	6SL3060-4AM00-0AA0
	0.60	6SL3060-4AU00-0AA0
	0.95	6SL3060-4AA10-0AA0
	1.20	6SL3060-4AW00-0AA0
	1.45	6SL3060-4AF10-0AA0
	2.80	6SL3060-4AJ20-0AA0
	5.00	6SL3060-4AA50-0AA0

Integration

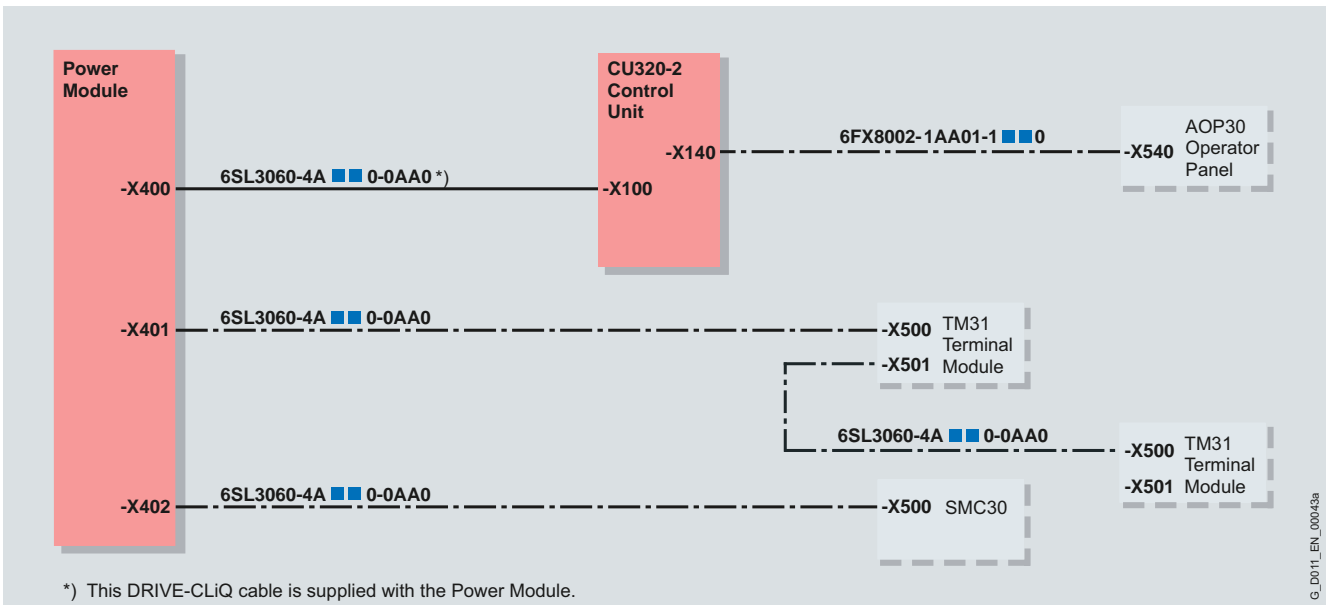

Connection example for a CU320-2 Control Unit

SINAMICS G130

Drive converter chassis units



2



SINAMICS G150

Drive converter cabinet units



3/2	Overview
3/3	Benefits
3/3	Application
3/3	Design
3/6	Selection and ordering data
3/6	Single circuit
3/6	Parallel circuit
3/7	Function
3/7	AOP30 Advanced Operator Panel
3/8	Communication with higher-level control and customer Terminal Module
3/8	Open-loop and closed-loop control functions
3/8	Software and protective functions
3/9	Power unit protection
3/9	Safety Integrated functions
3/11	Technical data
3/12	General technical data
3/13	Single circuit
3/17	Parallel circuit
3/19	Characteristic curves
3/19	Derating data
3/22	Overload capability
3/23	Options
3/25	Option selection matrix
3/26	Ordering examples
3/27	Description of options
3/39	Line-side power components
3/39	Recommended fuses
3/41	Conductor cross-sections and terminals
3/41	Single circuit
3/43	Parallel circuit
3/43	Minimum motor cable lengths for operation with power units connected in parallel
3/44	Cable cross-sections required for line and motor connection
3/44	Grounding and protective conductor cross-section

SINAMICS G150

Drive converter cabinet units

75 kW to 2700 kW

Overview



SINAMICS G150 drive converter cabinet units, versions A and C

With its SINAMICS G150 drive converter cabinet units, Siemens is offering a drive system on which all line-side and motor-side components as well as the Power Module are integrated extremely compactly into a specially designed cabinet enclosure. This approach minimizes the effort and expense required to configure and install them.

SINAMICS G150 has been specially tailored to meet the requirements of drives with quadratic and constant load characteristics, with medium performance requirements, and without regenerative feedback capability.

The control accuracy of the sensorless vector control is suitable for most applications, and additional actual speed value encoders are therefore superfluous.

SINAMICS G150 converters are optionally available with an encoder evaluation function in order to handle applications that require an encoder for plant-specific reasons.

SINAMICS G150 drive converter cabinet units offer an economic drive solution that can be matched to customer-specific requirements as a result of the wide range of available components and options.

There are two versions of the drive converter cabinet units:

■ Version A

All optionally available line connection components, such as the main switch, circuit breakers, line contactor, line fuses, line filter, motor-side components and additional monitoring devices, can be installed as required. This version is also available with power units connected in parallel.

■ Version C

This offers an extremely space-optimized structure without line-side components. This particularly narrow design can be used, for example, when line connection components are accommodated in a central low-voltage distribution panel (MCC) in the customer's plant or system.

SINAMICS G150 drive converter cabinet units are available for the following voltages and power ratings:

Line voltage	Output range for single circuit (versions A and C)	Output range for parallel circuit (version A)
380 ... 480 V 3 AC	110 ... 560 kW	630 ... 900 kW
500 ... 600 V 3 AC	110 ... 560 kW	630 ... 1000 kW
660 ... 690 V 3 AC	75 ... 800 kW	1000 ... 2700 kW

Degrees of protection are IP20 (standard), and as an option IP21, IP23, IP43 and IP54.

SINAMICS G150

Drive converter cabinet units

75 kW to 2700 kW

Benefits

- Particularly quiet and compact converters due to the use of state-of-the-art IGBT power semiconductors and an innovative cooling concept.
- Individual modules and power components can be replaced quickly and easily, which ensures a higher level of plant availability. The design of replaceable components is based on the principle that they must be quick and easy to change. In addition, the "SparesOnWeb" Internet tool makes it easy to view the spare parts that are available for the system components ordered.
- Can be easily integrated in automation solutions by means of a standard communications interface as well as a range of analog and digital interfaces.
- Easy commissioning and parameterization using interactive menus on the AOP30 Advanced Operator Panel with graphic LCD and plain-text display, or from a PC using the STARTER commissioning tool (→ Tools and configuration).
- Preset software functions make it easier to tailor the converter to the individual plant. For example, the key functions for controlling pumps are stored as a preprogrammed macro in the drive.
- Regarding EMC, the units are sub-divided into various zones, and as a consequence, they are extremely insensitive to disturbances and are very reliable in operation. With the help of simulated conditions, partitions have been designed to act as air guides and to help dissipate heat.
- Special measures used in the construction of the cabinets ensure that they remain mechanically durable throughout their entire life cycle. All components, from individual parts to the ready-to-connect cabinet, undergo rigorous testing throughout the entire production process. This guarantees a high level of functional reliability during installation and commissioning, as well as in operation.

Application

Variable-speed drives are ideal for all applications that involve moving, conveying, pumping or compressing solids, liquids or gases.

This means the following applications in particular:

- Pumps and fans
- Compressors
- Extruders and mixers
- Mills

Design

SINAMICS G150 drive converter cabinet units are characterized by their compact, modular, and service-friendly design.

A wide range of options is available depending on the cabinet version, which permits optimum adaptation of the drive system to the respective requirements (→ Options).

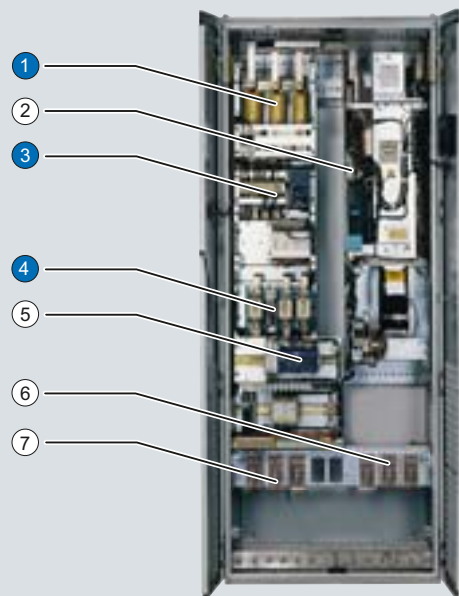

- ① Line reactor (≤ 500 kW standard) (Option L23)
 - ② PROFIBUS connection
 - ③ Line contactor (Option L13)
 - ④ Main control switch with fuses (Option L26)
 - ⑤ Customer Terminal Module
 - ⑥ Motor connection
 - ⑦ Line connection
- Standard version
● Options

Example of design of a SINAMICS G150 drive converter cabinet unit, version A with a CU320-2 DP Control Unit

SINAMICS G150

Drive converter cabinet units

75 kW to 2700 kW

Design (continued)

3

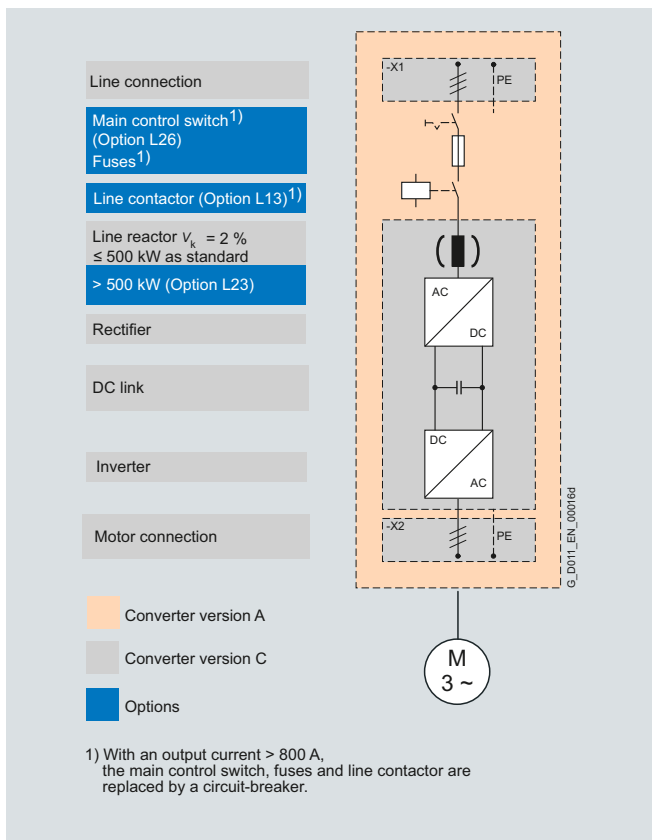

Basic design of a SINAMICS G150 drive converter cabinet unit with several essential options

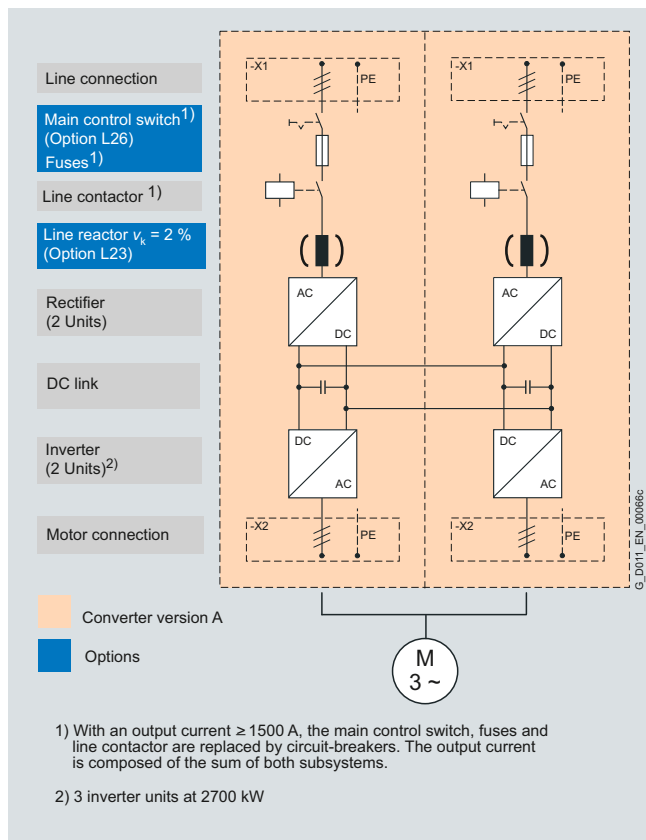

Basic design of a SINAMICS G150 drive converter cabinet unit in a parallel circuit in order to increase the power rating with several essential options

Design (continued)

Varnished PCBs

The following converter components are equipped as standard with varnished PCBs:

- Power Modules
- Control Units
- Sensor Modules
- Terminal Modules
- Advanced Operator Panel (AOP30)

The coating on the modules protects the sensitive SMD components against corrosive gases, chemically active dust and moisture.

Nickel-plated busbars

All of the copper busbars used in the converter cabinet are nickel-plated in order to achieve the best possible immunity to environmental effects. Further, the bare copper connections do not have to be cleaned for customer connections.

Note:

For some options, for technical reasons, parts of the copper busbars are not nickel plated.

Degrees of protection of cabinet units

The EN 60529 standard covers the protection of electrical equipment by means of housings, covers or equivalent, and includes:

- Protection of persons against accidental contact with live or moving parts within the housing and protection of the equipment against the ingress of solid foreign matter (touch protection and protection against ingress of solid foreign bodies)
- Protection of the equipment against the ingress of water (water protection)
- Abbreviations for the internationally agreed degrees of protection.

The degrees of protection are specified by abbreviations comprising the code letters IP and two digits.

Degrees of protection of the drive converter cabinet unit	First digit (touch protection and protection against ingress of foreign solid matter)	Second digit (protection of the equipment against the ingress of water)
IP20 (standard)	Protected against solid foreign bodies, diameter ≥ 12.5 mm.	No water protection
IP21 (option M21)	Protected against solid foreign bodies, diameter ≥ 12.5 mm.	Protected against drip water Vertically falling drip water shall not have a harmful effect.
IP23 (option M23)	Protected against solid foreign bodies, diameter ≥ 12.5 mm.	Protected against water spray Water sprayed on both sides of the vertical at an angle of up to 60° shall not have a harmful effect.
IP43 (option M43)	Protected against solid foreign bodies, diameter ≥ 1 mm.	Protected against water spray Water sprayed on both sides of the vertical at an angle of up to 60° shall not have a harmful effect.
IP54 (option M54)	Dust protected. Ingress of dust is not totally prevented, but dust must not be allowed to enter in such quantities that the functioning or safety of the equipment is impaired.	Protected against splash water Water splashing onto the enclosure from any direction shall not have a harmful effect.

SINAMICS G150

Drive converter cabinet units

75 kW to 2700 kW

Selection and ordering data

Single circuit

Type rating		Rated output current	SINAMICS G150 converter cabinet units (Order No. supplement, see below) Order No.
at 400 V 500 V or 690 V	at 60 Hz 460 V or 575 V		
kW	hp	A	
380 ... 480 V 3 AC			
110	150	210	6SL3710-1GE32-1 A3
132	200	260	6SL3710-1GE32-6 A3
160	250	310	6SL3710-1GE33-1 A3
200	300	380	6SL3710-1GE33-8 A3
250	400	490	6SL3710-1GE35-0 A3
315	500	605	6SL3710-1GE36-1 A3
400	600	745	6SL3710-1GE37-5 A3
450	700	840	6SL3710-1GE38-4 A3
560	800	985	6SL3710-1GE41-0 A3
500 ... 600 V 3 AC			
110	150	175	6SL3710-1GF31-8 A3
132	200	215	6SL3710-1GF32-2 A3
160	250	260	6SL3710-1GF32-6 A3
200	300	330	6SL3710-1GF33-3 A3
250	400	410	6SL3710-1GF34-1 A3
315	450	465	6SL3710-1GF34-7 A3
400	600	575	6SL3710-1GF35-8 A3
500	700	735	6SL3710-1GF37-4 A3
560	800	810	6SL3710-1GF38-1 A3
660 ... 690 V 3 AC			
75		85	6SL3710-1GH28-5 A3
90		100	6SL3710-1GH31-0 A3
110		120	6SL3710-1GH31-2 A3
132		150	6SL3710-1GH31-5 A3
160		175	6SL3710-1GH31-8 A3
200		215	6SL3710-1GH32-2 A3
250		260	6SL3710-1GH32-6 A3
315		330	6SL3710-1GH33-3 A3
400		410	6SL3710-1GH34-1 A3
450		465	6SL3710-1GH34-7 A3
560		575	6SL3710-1GH35-8 A3
710		735	6SL3710-1GH37-4 A3
800		810	6SL3710-1GH38-1 A3

Order No. supplement

Version A

All available line connection components can be installed as required

A

Version C

Especially space-saving design

C

Parallel circuit

Type rating		Rated output current	Converter cabinet units SINAMICS G150, version A Order No.
at 400 V 500 V or 690 V	at 60 Hz 460 V or 575 V		
kW	hp	A	
380 ... 480 V 3 AC			
630	900	1120	6SL3710-2GE41-1AA3
710	1000	1380	6SL3710-2GE41-4AA3
900	1250	1560	6SL3710-2GE41-6AA3
500 ... 600 V 3 AC			
630	900	860	6SL3710-2GF38-6AA3
710	1000	1070	6SL3710-2GF41-1AA3
1000	1250	1360	6SL3710-2GF41-4AA3
660 ... 690 V 3 AC			
1000		1070	6SL3710-2GH41-1AA3
1350		1360	6SL3710-2GH41-4AA3
1500		1500	6SL3710-2GH41-5AA3
1750		1729	6SL3710-2GH41-8EA3
1950		1948	6SL3710-2GH42-0EA3
2150		2158	6SL3710-2GH42-2EA3
2400		2413	6SL3710-2GH42-4EA3
2700		2752	6SL3710-2GH42-7EA3

Note: The power data in hp units are based on the NEC/CEC standards for the North American market.

Function

AOP30 Advanced Operator Panel



An AOP30 Advanced Operator Panel is located in the cabinet door of the converter for operation, monitoring and commissioning tasks.

The AOP30's two-stage safety concept prevents unintentional or unauthorized changes to settings. Operation of the drive from the operator panel can be disabled by the keyboard lock so that only parameter values and process variables can be displayed on the operating panel. The OFF key is factory-set to active but can also be deactivated by the customer. A password can be used to prevent the unauthorized modification of converter parameters.

The user is guided by interactive menus through the drive-commissioning screens. When commissioning the drive for the first time, only 6 motor parameters (which can be found on a motor rating plate) have to be entered on the AOP30. The control is then optimized automatically to fine-tune the converter to the motor.

English, German, French, Italian, Spanish and **Chinese** are stored on the CU320-2 Control Unit's CompactFlash card as operator panel languages. The desired language must be downloaded to the AOP30 prior to commissioning. **Russian, Polish** and **Czech** are available in addition to these standard panel languages. These can be downloaded free of charge from the Internet under the following link:
<http://support.automation.siemens.com/>

Examples of plain-text displays at various phases of operation are shown below.

First commissioning is carried out using the operator panel.

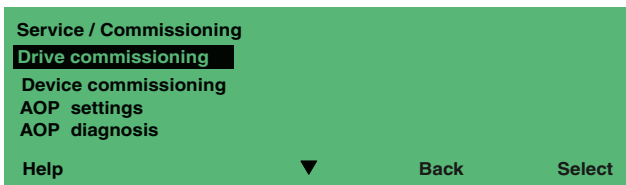

Only 6 motor parameters have to be entered:

Power, speed, current, cos phi, voltage and frequency of the motor.

This information can be found on the motor rating plate, and must be entered into the screens on the display by following a short, menu-assisted procedure. The motor cooling method must also be specified.

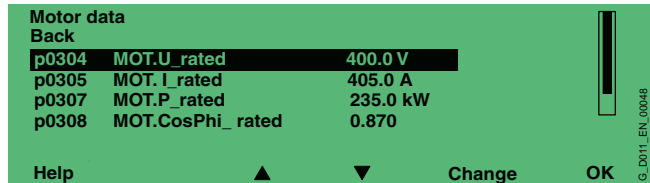

The next screen contains the parameter values that are used to automatically optimize the control.

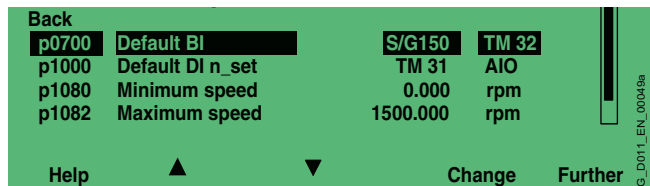

During **operation**, actual data are output on the display as absolute values, such as setpoint and actual values, or it is possible to parameterize up to 3 process variables as a quasi-analog bar display.

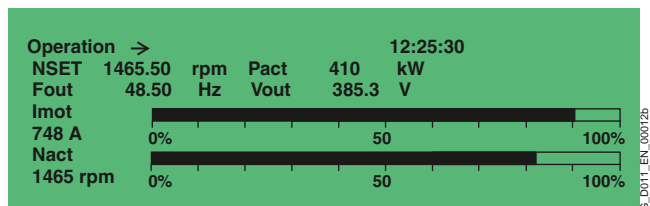
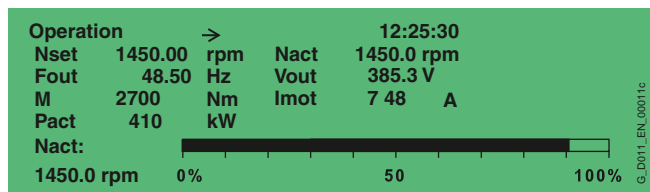

Any **alarms** that occur are signaled by flashing of the yellow "ALARM" LED, **faults** by lighting up of the red "FAULT" LED. There is also an indication of the cause displayed in plain text on the display's status line.

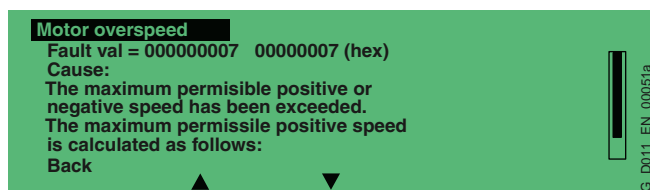
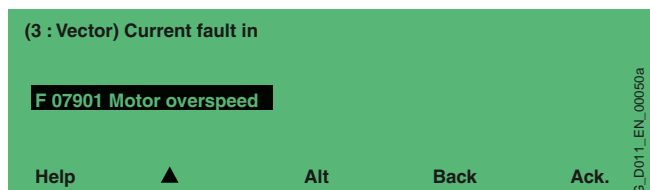

SINAMICS G150

Drive converter cabinet units

75 kW to 2700 kW

Function (continued)**Communication with higher-level control and customer Terminal Module**

A PROFIBUS interface on the CU320-2 DP Control Unit is provided as standard as the customer interface.

When using the Control Unit CU320-2 PN (PROFINET) (Option **K95**), communication is realized via PROFINET corresponding to the PROFIdrive profile.

The Control Unit can be connected to the higher-level control via its digital inputs and outputs to exchange digital signals.

The inputs and outputs available as standard can be optionally expanded using a TB30 Terminal Board (option **L62**) and/or up to 2 TM31 Terminal Modules (option **G60** or **G61**).

To simplify configuration and commissioning of the drive, the optional TM31 Terminal Module can be preset to a variety of factory settings.

The SINAMICS Low Voltage Engineering Manual contains additional information and is available as a PDF file on the CD-ROM included with Catalog D 11.

Open-loop and closed-loop control functions

The converter control contains a high-quality, sensorless vector control with speed and current controls as well as motor and converter protection.

Software and protective functions

The software functions available as standard are described below:

Software and protective functions	Description
Setpoint input	The setpoint can be input both internally and externally. It is applied internally as a fixed setpoint, motorized potentiometer setpoint or jog setpoint and externally via the communications interface or an analog input on customer Terminal Module. The internal fixed setpoint and the motorized potentiometer setpoint can be switched over or adjusted using control commands via all interfaces.
Motor identification	The automatic motor identification function makes commissioning faster and easier and optimizes closed-loop control of the drive.
Ramp-function generator	A convenient ramp-function generator with separately adjustable ramping times, together with adjustable rounding times in the lower and upper speed ranges, allows the drive to be smoothly accelerated and braked. As a consequence, this avoids the drive train from being overloaded and reduces the stress on mechanical components. The down ramps can be parameterized separately for quick stop.
V_{dc max} controller	The V _{dc max} controller automatically prevents overvoltages in the DC link if the set down ramp is too short, for example. This may also extend the set ramp-down time.
Kinetic buffering (KIP)	For supply voltage dips, the kinetic energy of the rotating drive is used to buffer the DC link and therefore prevents fault trips. The drive converter remains operational as long as the drive can provide regenerative energy as a result of its motion and the DC link voltage does not drop below the trip threshold. When the line supply recovers within this time, the drive is again accelerated up to its setpoint speed.
Automatic restart¹⁾	The automatic restart switches the drive on again when the power is restored after a power failure, and ramps up to the current speed setpoint.
Flying restart¹⁾	The "Flying restart" function allows the converter to be switched to a motor that is still turning.
Technology controller	The "Technology controller" function module allows simple control functions to be implemented, e.g. level control or volumetric flow control. The technology controller is designed as a PID controller, whereby the differentiator can be switched to the control deviation channel or the actual value channel (factory setting). The P, I, and D components can be set separately.
Free function blocks	Using the freely programmable function blocks, it is easy to implement logic and arithmetic functions for controlling the SINAMICS G150 unit. The blocks can be programmed by means of an operator panel or the STARTER commissioning tool.
Drive Control Chart (DCC)	Drive Control Chart (DCC) is an additional tool for the easy configuration of process-oriented functions for the SINAMICS G150. The block library contains a large selection of control, arithmetic and logic blocks as well as extensive open-loop and closed-loop control functions. The user-friendly DCC editor enables easy graphical configuration and a clear representation of control loop structures as well as a high degree of reusability of existing diagrams. DCC is an add-on to the STARTER commissioning tool (→ Tools and configuration).
Pt detection for motor protection	A motor model stored in the converter software calculates the motor temperature based on the current speed and load. More exact sensing of the temperature, which also takes into account the influence of the ambient temperature, is possible by means of direct temperature sensing using KTY84 sensors in the motor winding.
Motor temperature evaluation	Motor protection by evaluating a KTY84, PTC or Pt100 temperature sensor. When a KTY84 sensor is connected, the limit values can be set for alarm or shutdown. When a PTC thermistor is connected, the system reaction to triggering of the thermistor (alarm or shutdown) can be defined.
Motor blocking protection	A blocked motor is recognized and protected against thermal overloading by shutting down.

¹⁾ Factory setting: not activated (can be programmed)

Function (continued)

Power unit protection	Description
Ground fault monitoring at output end	A ground fault on the output side is detected by an aggregate current monitor and results in shutdown in grounded-neutral systems.
Electronic short-circuit protection at output end	A short-circuit at the output (e.g. at the converter output terminals, in the motor cable or in the motor terminal box) is detected and the converter shuts down with "fault".
Thermal overload protection	An alarm is issued first when the overtemperature threshold responds. If the temperature rises further, the unit either shuts down or independently adjusts the pulse frequency or output current so that a reduction in the thermal load is achieved. Once the cause of the fault has been eliminated (e.g. cooling has been improved), the original operating values are automatically resumed.

Safety Integrated functions

The integrated safety functions of SINAMICS provide highly-effective application-oriented protection for personnel and machinery.

SINAMICS G150 offers the following Safety Integrated functions as standard (terms as defined in IEC 61800-5-2):

- Safe Torque Off (STO)
- Safe Stop 1 (SS1)

The Safety Integrated functions are implemented electronically and therefore offer short response times in comparison to solutions with externally implemented monitoring functions.

Legal framework

Machine manufacturers and plant construction companies must ensure that their machines or plants cannot cause danger as a result of electric shock, heat or radiation or hazards caused by functional faults. In Europe, for example, compliance with the machinery directive is legally stipulated by the EU industrial safety directive.

In order to ensure compliance with this directive, it is recommended that the corresponding harmonized European standards are applied. This initiates the assumption of conformity and gives manufacturers and operators the legal security when complying with both national regulations and EU directives. The machine manufacturer uses the CE marking to document the compliance with all relevant directives and regulations in the free movement of goods.

Safety-related standards

Functional safety is specified in various standards. EN ISO 12100 and EN ISO 14121-1, for example, are concerned with the design and risk assessment of machines. Functional and safety-related requirements of control systems with relevance to safety are defined in EN 62061 (applicable only to electrical and electronic control systems) and EN ISO 13849-1. This will replace EN 954-1 – which is still being commonly used – at the end of 2011.

The above-mentioned standards define different safety requirements that the machine has to satisfy in accordance with the risk, frequency of a dangerous situation, probability of occurrence and the opportunities for recognizing impending danger.

- EN 954-1: Categories B, 1 ... 4
- EN ISO 13849-1: Performance Level PL a ... e
- EN 62061: Safety Integrity Level SIL 1 ... 3

Safety functions integrated in the drive with SINAMICS

The safety functions integrated in SINAMICS satisfy the requirements of:

- Category 3 according to EN 954-1 or EN ISO 13849-1
- Safety Integrity Level (SIL) 2 according to EN 61508
- Performance Level (PL) d according to EN ISO 13849-1

In addition, the Safety Integrated functions of SINAMICS are generally certified by independent institutes. An up-to-date list of certified components is available on request from your local Siemens office.

Basic Functions and Extended Functions

The Safety Integrated functions of the SINAMICS drive system are grouped into basic functions and extended functions.

The above mentioned Basic Functions STO and SS1 are included in the standard scope of SINAMICS G150 and do not require a license. Extended Functions, which will require a license, are presently still not available for SINAMICS G150.

The Safety Integrated functions are either activated via a terminal at the Control Unit and at the power unit, or via PROFIBUS or PROFINET with the PROFIsafe profile.

An encoder is not required to use Basic Functions.

The Safety Integrated functions currently available in SINAMICS G150 are subsequently described in more detail (terms as defined in IEC 61800-5-2):

SINAMICS G150

Drive converter cabinet units

75 kW to 2700 kW

Function (continued)

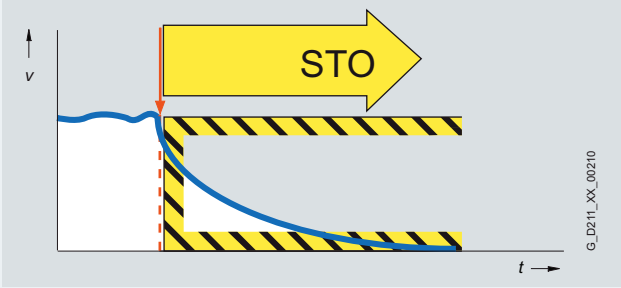
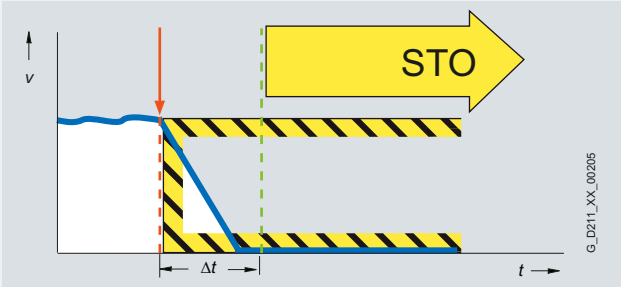
Safety Integrated	Description
Safe Torque Off (STO)	<p><u>Function description</u></p> <p>This function is a mechanism that prevents the drive from restarting unexpectedly, in accordance with EN 60204-1, Section 5.4. Safe Torque Off disables the drive pulses and disconnects the power supply to the motor (corresponds to Stop Category 0 of EN 60204-1). The drive is reliably torque-free. This state is monitored internally in the drive.</p> <p><u>Application, customer benefits</u></p> <p>STO has the immediate effect that the drive cannot supply any torque-generating energy. STO can be used wherever the drive will reach a standstill by itself due to the load torque or friction in a sufficiently short time or when "coasting down" of the drive will not have any relevance for safety.</p>  <p>The diagram shows velocity (v) on the y-axis and time (t) on the x-axis. A blue curve shows the drive's velocity decreasing from a steady state to zero. A vertical red dashed line marks the start of the STO event. A yellow arrow labeled 'STO' points to the right, indicating the duration of the safe torque-off state. A hatched area below the velocity curve indicates the period where the drive is torque-free.</p> <p style="text-align: right;">G_D211_XX_00210</p>
Safe Stop 1 (SS1)	<p><u>Function description</u></p> <p>The Safe Stop 1 function can safely stop the drive in accordance with EN 60204-1, Stop Category 1. When the SS1 function is selected, the drive independently brakes along a quick stop ramp (OFF3) and automatically activates Safe Torque Off when the parameterized safety delay time Δt has expired.</p> <p><u>Application, customer benefits</u></p> <p>With this integrated self-braking function, complex external monitoring devices are not required. It is often possible to also eliminate mechanical brakes which wear – or to lessen the load on them, so that maintenance costs and the stresses on the machine can be reduced. Safe Stop 1 is employed for applications which require monitored braking, e.g. on centrifuges or conveyor vehicles.</p>  <p>The diagram shows velocity (v) on the y-axis and time (t) on the x-axis. A blue curve shows the drive's velocity decreasing from a steady state to zero. A vertical red dashed line marks the start of the SS1 event. A yellow arrow labeled 'STO' points to the right, indicating the duration of the safe torque-off state. A hatched area below the velocity curve indicates the period where the drive is torque-free. A horizontal double-headed arrow labeled Δt indicates the safety delay time between the start of the stop and the activation of STO.</p> <p style="text-align: right;">G_D211_XX_00205</p>
Terminal module for controlling STO and SS1 (option K82)	<p>The terminal module is used to control the "Basic Safety Functions" over a wide voltage range from 24 V to 240 V DC/AC. This means that the "STO" and "SS1" safety functions can be flexibly controlled from the signal voltages in the plant.</p> <p>See → Description of the options (K82)</p>

Technical data

The most important directives and standards are listed below. These are used as basis for the SINAMICS drive system and they must be carefully observed to achieve an EMC-compliant configuration that is safe both functionally and in operation.

European directives

2006/95/EC	Low-voltage directive: Legal guidelines of the EU member states concerning electrical equipment for use within specified voltage limits
2004/108/EC	EMC directive: Legal guidelines of the EU member states for electromagnetic compatibility

European Standards

EN 954-1	Safety of machinery – Safety-related parts of controls Part 1: General design principles
EN ISO 13849-1	Safety of machinery – Safety-related parts of controls Part 1: General design principles (ISO 13849-1:2006) (replaced EN 954-1)
EN 60146-1-1	Semiconductor converters – General requirements and line-commutated converters Part 1-1: Specification of basic requirements
EN 60204-1	Electrical equipment of machines Part 1: General requirements
EN 60529	Degrees of protection provided by enclosures (IP code)
EN 61508-1	Functional safety of electrical/electronic/programmable electronic safety-related systems Part 1: General requirements
EN 61800-2	Adjustable speed electrical power drive systems Part 2: General requirements – Rating specifications for low-voltage adjustable frequency AC power drive systems
EN 61800-3	Adjustable speed electrical power drive systems Part 3: EMC requirements and specific test methods
EN 61800-5-1	Adjustable speed electrical power drive systems Part 5: Safety requirements Main section 1: Electrical and thermal requirements
EN 61800-5-2	Adjustable speed electrical power drive systems Part 5-2: Safety requirements – Functional safety (IEC 61800-5-2:2007)

North American standards

UL508A	Industrial Control Panels
UL508C	Power Conversion Equipment
CSA C22.2 No. 14	Industrial Control Equipment

Approvals

cULus, cURus	Testing by UL (Underwriters Laboratories, http://www.ul.com) according to UL and CSA standards
--------------	---

Test symbol:

(→ Appendix, Approvals)

SINAMICS G150

Drive converter cabinet units

75 kW to 2700 kW

Technical data (continued)**General technical data**

Electrical data		Single circuit	Parallel circuit
Line voltages and output ranges	• 380 ... 480 V 3 AC, ±10 % (-15 % < 1 min)	110 ... 560 kW	630 ... 900 kW
	• 500 ... 600 V 3 AC, ±10 % (-15 % < 1 min)	110 ... 560 kW	630 ... 1000 kW
	• 660 ... 690 V 3 AC, ±10 % (-15 % < 1 min)	75 ... 800 kW	1000 ... 2700 kW
Types of supplies	Grounded TN/TT systems or ungrounded IT systems (a grounded phase conductor is not permiss. in 690 V syst.)		
Line frequency	47 ... 63 Hz		
Output frequency	0 ... 650 Hz		
Power factor			
- Fundamental mode	> 0.96		
- Total	0.75 ... 0.93		
Efficiency	> 98 %		
Overvoltage category	III to EN 61800-5-1		
Control method	Vector control with and without encoder or V/f control		
Fixed speeds	15 fixed speeds plus 1 minimum speed, parameterizable (in the default setting, 3 fixed setpoints plus 1 minimum speed are selectable using terminal block/PROFIBUS)		
Skipped speed ranges	4, programmable		
Setpoint resolution	0.001 rpm digital 12 bit analog		
Braking operation	Optional via braking unit		
Mechanical data			
Degree of protection	IP20 (higher degrees of protection up to IP54 optional)		
Protection class	I acc. to EN 61800-5-1		
Touch protection	EN 50274 / BGV A3		
Cabinet system	Rittal TS 8, doors with double-barb lock, three-section base plates for cable entry		
Paint finish	RAL 7035 (indoor requirements)		
Type of cooling	Forced air cooling AF acc. to EN 60146		
Ambient conditions			
	Storage	Transport	Operation
Ambient temperature	-25 ... +55 °C	-25 ... +70 °C from <u>-40 °C</u> for 24 hours	<u>0</u> ... +40 °C up to +50 °C see derating data
Relative humidity (condensation not permissible)	<u>5 ... 95 %</u>	5 ... 95 % at 40 °C	<u>5 ... 95 %</u>
	Class 1K4 to EN 60721-3-1	Class 2K3 to EN 60721-3-2	Class 3K3 to EN 60721-3-3
Environmental class/harmful chemical substances	Class 1C2 acc. to EN 60721-3-1	Class 2C2 acc. to EN 60721-3-2	Class 3C2 acc. to EN 60721-3-3
Organic/biological influences	Class 1B1 acc. to EN 60721-3-1	Class 2B1 acc. to EN 60721-3-2	Class 3B1 acc. to EN 60721-3-3
Pollution degree	2 acc. to EN 61800-5-1		
Installation altitude	Up to 2000 m above sea level without derating, > 2000 m, see derating data		
Mechanical stability			
	Storage	Transport	Operation
Vibratory load			
	- Deflection	1.5 mm at <u>5</u> ... 9 Hz	<u>3.1 mm</u> at <u>5</u> ... 9 Hz
- Acceleration	5 m/s ² at > 9 ... 200 Hz Class 1M2 to EN 60721-3-1	10 m/s ² at > 9 ... 200 Hz Class 2M2 to EN 60721-3-2	10 m/s ² at > 58 ... 200 Hz –
Shock load			
	- Acceleration	40 m/s ² at 22 ms Class 1M2 to EN 60721-3-1	100 m/s ² at 11 ms Class 2M2 to EN 60721-3-2
Compliance with standards			
CE Label	Acc. to EMC Directive No. 2004/108/EC and Low-Voltage Directive No. 2006/95/EC		
Radio interference suppression	The SINAMICS G150 converter systems are not designed for connection to the public power network ("first environment"). RFI suppression is compliant with the EMC product standard for variable-speed drives EN 61800-3, "Second environment" (industrial networks). The equipment can cause electromagnetic interference when it is connected to the public network. However, if supplementary measures are taken (e.g. line filter, → Option L00) operation in the "first environment" is possible. ¹⁾		

Deviations from the specified classes are underlined.

1) Applies to motor cable lengths < 100 m.

Technical data (continued)

Technical data for single circuit

Line voltage 380 ... 480 V 3 AC		SINAMICS G150 converter cabinet units								
		6SL3710-1GE32-1.A3	6SL3710-1GE32-6.A3	6SL3710-1GE33-1.A3	6SL3710-1GE33-8.A3	6SL3710-1GE35-0.A3	6SL3710-1GE36-1.A3	6SL3710-1GE37-5.A3	6SL3710-1GE38-4.A3	6SL3710-1GE41-0.A3
Type rating										
• at I_L at 50 Hz 400 V ¹⁾	kW	110	132	160	200	250	315	400	450	560
• at I_H at 50 Hz 400 V ¹⁾	kW	90	110	132	160	200	250	315	400	450
• at I_L at 60 Hz 460 V ²⁾	hp	150	200	250	300	400	500	600	600	800
• at I_H at 60 Hz 460 V ²⁾	hp	125	150	200	250	350	350	450	500	700
Output current										
• Rated current I_{rated}	A	210	260	310	380	490	605	745	840	985
• Base load current I_L ³⁾	A	205	250	302	370	477	590	725	820	960
• Base load current I_H ⁴⁾	A	178	233	277	340	438	460	570	700	860
Input current										
• Rated input current ⁵⁾	A	229	284	338	395	509	629	775	873	1024
• Input current, max.	A	335	410	495	606	781	967	1188	1344	1573
• Current requirement, 24 V DC auxiliary power supply ⁶⁾	A	1.1	1.1	1.35	1.35	1.35	1.4	1.4	1.4	1.5
Power loss	kW	2.9	3.8	4.4	5.3	6.4	8.2	9.6	10.1	14.4
Cooling-air demand	m ³ /s	0.17	0.23	0.36	0.36	0.36	0.78	0.78	0.78	1.48
Sound pressure level L_{pA} (1 m) at 50/60 Hz	dB	67/68	69/73	69/73	69/73	69/73	70/73	70/73	70/73	72/75
Cable lengths between converter and motor ⁸⁾										
• shielded	m	300	300	300	300	300	300	300	300	300
• unshielded	m	450	450	450	450	450	450	450	450	450
Dimensions										
• Width for version A/C	mm	800/400	800/400	800/400	1000/400	1000/400	1200/600	1200/600	1200/600	1600/1000
• Height ⁷⁾	mm	2000	2000	2000	2000	2000	2000	2000	2000	2000
• Depth	mm	600	600	600	600	600	600	600	600	600
Weight (degree of protection IP20, without options) for version A/C, approx.	kg	460/225	460/225	670/300	670/300	670/300	750/670	750/670	780/670	1100/880

Note: The power data in hp units are based on the NEC/CEC standards for the North American market.

Information on the line connection, motor connection and cabinet grounding is provided under

Cable cross-sections and connections.

¹⁾ Rated power of a typ. 6-pole standard induction motor based on I_L or I_H at 50 Hz 400 V 3 AC

²⁾ Rated power of a typ. 6-pole standard induction motor based on I_L or I_H at 60 Hz 460 V 3 AC

³⁾ The base load current I_L is based on a duty cycle of 110 % for 60 s or 150 % for 10 s with a duty cycle duration of 300 s. See characteristic curves (→ Overload capability).

⁴⁾ The base load current I_H is based on a duty cycle of 150 % for 60 s or 160 % for 10 s with a duty cycle duration of 300 s. See characteristic curves (→ Overload capability).

⁵⁾ The current values given here are based on the rated output current.

⁶⁾ If the drive control is to remain active after a main infeed failure, the converter must be externally supplied with 24 V DC. The following should also be taken into account:

– CU320-2: 1 A
– TM31: 0.5 A
– AOP30: 0.2 A
– SMC: 0.6 A
– The current requirement of the digital inputs/outputs.

⁷⁾ Version A: The cabinet height increases by 250 mm for degree of protection IP21, 400 mm for degrees of protection IP23, IP43 and IP54, 405 mm for the options **M13** and **M78**.
Version C: The cabinet height increases by 250 mm for IP21 degree of protection, 400 mm for IP23, IP43 and IP54 degrees of protection.

⁸⁾ Longer cable lengths for specific configurations are available on request.

SINAMICS G150

Drive converter cabinet units

75 kW to 2700 kW

Technical data (continued)

Line voltage 500 ... 600 V 3 AC		SINAMICS G150 converter cabinet units								
		6SL3710-1GF31-8.A3	6SL3710-1GF32-2.A3	6SL3710-1GF32-6.A3	6SL3710-1GF33-3.A3	6SL3710-1GF34-1.A3	6SL3710-1GF34-7.A3	6SL3710-1GF35-8.A3	6SL3710-1GF37-4.A3	6SL3710-1GF38-1.A3
Type rating										
• at I_L at 50 Hz 500 V ¹⁾	kW	110	132	160	200	250	315	400	500	560
• at I_H at 50 Hz 500 V ¹⁾	kW	90	110	132	160	200	250	315	450	500
• at I_L at 60 Hz 575 V ²⁾	hp	150	200	250	300	400	450	600	700	800
• at I_H at 60 Hz 575 V ²⁾	hp	150	200	200	250	350	450	500	700	700
Output current										
• Rated current I_{rated}	A	175	215	260	330	410	465	575	735	810
• Base load current I_L ³⁾	A	171	208	250	320	400	452	560	710	790
• Base load current I_H ⁴⁾	A	157	192	233	280	367	416	514	657	724
Input current										
• Rated input current ⁵⁾	A	191	224	270	343	426	483	598	764	842
• Input current, max.	A	279	341	410	525	655	740	918	1164	1295
• Current requirement, 24 V DC auxiliary power supply ⁶⁾	A	1.35	1.35	1.35	1.4	1.4	1.4	1.4	1.5	1.5
Power loss	kW	3.8	4.2	5.0	6.1	8.1	7.8	8.7	12.7	14.1
Cooling-air demand	m ³ /s	0.36	0.36	0.36	0.36	0.78	0.78	0.78	1.48	1.48
Sound pressure level L_{pA} (1 m) at 50/60 Hz	dB	69/73	69/73	69/73	69/73	72/75	72/75	72/75	72/75	72/75
Cable lengths between converter and motor ³⁾										
• shielded	m	300	300	300	300	300	300	300	300	300
• unshielded	m	450	450	450	450	450	450	450	450	450
Dimensions										
• Width for version A/C	mm	800/400	800/400	800/400	800/400	1200/600	1200/600	1200/600	1600/1000	1600/1000
• Height ⁷⁾	mm	2000	2000	2000	2000	2000	2000	2000	2000	2000
• Depth	mm	600	600	600	600	600	600	600	600	600
Weight (degree of protection IP20, without options) for version A/C, approx.	kg	460/300	460/300	460/300	460/300	750/670	750/670	860/670	1150/940	1150/960

Note: The power data in hp units are based on the NEC/CEC standards for the North American market.

Information on the line connection, motor connection and cabinet grounding is provided under

Cable cross-sections and connections.

¹⁾ Rated power of a typ. 6-pole standard induction motor based on I_L or I_H at 50 Hz 500 V 3 AC

²⁾ Rated power of a typ. 6-pole standard induction motor based on I_L or I_H at 60 Hz 575 V 3 AC

³⁾ The base load current I_L is based on a duty cycle of 110 % for 60 s or 150 % for 10 s with a duty cycle duration of 300 s. See characteristic curves (→ Overload capability).

⁴⁾ The base load current I_H is based on a duty cycle of 150 % for 60 s or 160 % for 10 s with a duty cycle duration of 300 s. See characteristic curves (→ Overload capability).

⁵⁾ The current values given here are based on the rated output current.

⁶⁾ If the drive control is to remain active after a main infeed failure, the converter must be externally supplied with 24 V DC.

The following should also be taken into account:

- CU320-2: 1 A
- TM31: 0.5 A
- AOP30: 0.2 A
- SMC: 0.6 A
- The current requirement of the digital inputs/outputs.

⁷⁾ Version A: The cabinet height increases by 250 mm for degree of protection IP21, 400 mm for degrees of protection IP23, IP43 and IP54, 405 mm for the options **M13** and **M78**.
Version C: The cabinet height increases by 250 mm for IP21 degree of protection, 400 mm for IP23, IP43 and IP54 degrees of protection.

⁸⁾ Longer cable lengths for specific configurations are available on request.

Technical data (continued)

Line voltage 660 ... 690 V 3 AC		SINAMICS G150 converter cabinet units						
		6SL3710-1GH28-5.A3	6SL3710-1GH31-0.A3	6SL3710-1GH31-2.A3	6SL3710-1GH31-5.A3	6SL3710-1GH31-8.A3	6SL3710-1GH32-2.A3	6SL3710-1GH32-6.A3
Type rating								
• at I_L at 50 Hz 690 V ¹⁾	kW	75	90	110	132	160	200	250
• at I_H at 50 Hz 690 V ¹⁾	kW	55	75	90	110	132	160	200
Output current								
• Rated current I_{rated}	A	85	100	120	150	175	215	260
• Base load current I_L ³⁾	A	80	95	115	142	171	208	250
• Base load current I_H ⁴⁾	A	76	89	107	134	157	192	233
Input current								
• Rated input current ⁵⁾	A	93	109	131	164	191	224	270
• Input current, max.	A	131	155	188	232	279	341	410
• Current requirement, 24 V DC auxiliary power supply ⁶⁾	A	1.1	1.1	1.1	1.1	1.35	1.35	1.35
Power loss	kW	1.7	2.1	2.7	2.8	3.8	4.2	5.0
Cooling-air demand	m ³ /s	0.17	0.17	0.17	0.17	0.36	0.36	0.36
Sound pressure level L_{pA} (1 m) at 50/60 Hz	dB	67/68	67/68	67/68	67/68	67/73	67/73	67/73
Cable lengths between converter and motor ⁸⁾								
• shielded	m	300	300	300	300	300	300	300
• unshielded	m	450	450	450	450	450	450	450
Dimensions								
• Width for version A/C	mm	800/400	800/400	800/400	800/400	800/400	800/400	800/400
• Height ⁷⁾	mm	2000	2000	2000	2000	2000	2000	2000
• Depth	mm	600	600	600	600	600	600	600
Weight (degree of protection IP20, without options) for version A/C, approx.	kg	460/225	460/225	460/225	460/225	670/300	670/300	670/300

Note: The power data in hp units are based on the NEC/CEC standards for the North American market.

Information on the line connection, motor connection and cabinet grounding is provided under

Cable cross-sections and connections.

¹⁾ Rated power of a typ. 6-pole standard induction motor based on I_L or I_H at 50 Hz 690 V 3 AC

³⁾ The base load current I_L is based on a duty cycle of 110 % for 60 s or 150 % for 10 s with a duty cycle duration of 300 s. See characteristic curves (→ Overload capability).

⁴⁾ The base load current I_H is based on a duty cycle of 150 % for 60 s or 160 % for 10 s with a duty cycle duration of 300 s. See characteristic curves (→ Overload capability).

⁵⁾ The current values given here are based on the rated output current.

⁶⁾ If the drive control is to remain active after a main infeed failure, the converter must be externally supplied with 24 V DC. The following should also be taken into account:

- CU320-2: 1 A
- TM31: 0.5 A
- AOP30: 0.2 A
- SMC: 0.6 A

– The current requirement of the digital inputs/outputs.

⁷⁾ Version A: The cabinet height increases by 250 mm for degree of protection IP21, 400 mm for degrees of protection IP23, IP43 and IP54, 405 mm for the options **M13** and **M78**.
Version C: The cabinet height increases by 250 mm for IP21 degree of protection, 400 mm for IP23, IP43 and IP54 degrees of protection.

⁸⁾ Longer cable lengths for specific configurations are available on request.

SINAMICS G150

Drive converter cabinet units

75 kW to 2700 kW

Technical data (continued)

Line voltage 660 ... 690 V 3 AC		SINAMICS G150 converter cabinet units					
		6SL3710-1GH33-3.A3	6SL3710-1GH34-1.A3	6SL3710-1GH34-7.A3	6SL3710-1GH35-8.A3	6SL3710-1GH37-4.A3	6SL3710-1GH38-1.A3
Type rating							
• at I_L at 50 Hz 690 V ¹⁾	kW	315	400	450	560	710	800
• at I_H at 50 Hz 690 V ¹⁾	kW	250	315	400	450	560	710
Output current							
• Rated current I_{rated}	A	330	410	465	575	735	810
• Base load current I_L ³⁾	A	320	400	452	560	710	790
• Base load current I_H ⁴⁾	A	280	367	416	514	657	724
Input current							
• Rated input current ⁵⁾	A	343	426	483	598	764	842
• Input current, max.	A	525	655	740	918	1164	1295
• Current requirement, 24 V DC auxiliary power supply ⁶⁾	A	1.35	1.4	1.4	1.4	1.5	1.5
Power loss	kW	6.1	8.1	9.1	10.8	13.5	14.7
Cooling-air demand	m ³ /s	0.36	0.78	0.78	0.78	1.48	1.48
Sound pressure level L_{pA} (1 m) at 50/60 Hz	dB	67/73	72/75	72/75	72/75	72/75	72/75
Cable lengths between converter and motor ⁸⁾							
• shielded	m	300	300	300	300	300	300
• unshielded	m	450	450	450	450	450	450
Dimensions							
• Width for version A/C	mm	800/400	1200/600	1200/600	1200/600	1600/1000	1600/1000
• Height ⁷⁾	mm	2000	2000	2000	2000	2000	2000
• Depth	mm	600	600	600	600	600	600
Weight (degree of protection IP20, without options) for version A/C, approx.	kg	670/300	780/670	780/670	840/670	1320/940	1360/980

Note: The power data in hp units are based on the NEC/CEC standards for the North American market.

Information on the line connection, motor connection and cabinet grounding is provided under

Cable cross-sections and connections.

¹⁾ Rated power of a typ. 6-pole standard induction motor based on I_L or I_H at 50 Hz 690 V 3 AC

³⁾ The base load current I_L is based on a duty cycle of 110 % for 60 s or 150 % for 10 s with a duty cycle duration of 300 s. See characteristic curves (→ Overload capability).

⁴⁾ The base load current I_H is based on a duty cycle of 150 % for 60 s or 160 % for 10 s with a duty cycle duration of 300 s. See characteristic curves (→ Overload capability).

⁵⁾ The current values given here are based on the rated output current.

⁶⁾ If the drive control is to remain active after a main infeed failure, the converter must be externally supplied with 24 V DC. The following should also be taken into account:

- CU320-2: 1 A
- TM31: 0.5 A
- AOP30: 0.2 A
- SMC: 0.6 A
- The current requirement of the digital inputs/outputs.

⁷⁾ Version A: The cabinet height increases by 250 mm for degree of protection IP21, 400 mm for degrees of protection IP23, IP43 and IP54, 405 mm for the options **M13** and **M78**.
Version C: The cabinet height increases by 250 mm for IP21 degree of protection, 400 mm for IP23, IP43 and IP54 degrees of protection.

⁸⁾ Longer cable lengths for specific configurations are available on request.

Technical data (continued)

Technical data for parallel circuit

		SINAMICS G150 converter cabinet units, version A					
		6SL3710-2GE41-1AA3	6SL3710-2GE41-4AA3	6SL3710-2GE41-6AA3	6SL3710-2GF38-6AA3	6SL3710-2GF41-1AA3	6SL3710-2GF41-4AA3
Line voltage		380 ... 480 V 3 AC			500 ... 600 V 3 AC		
Type rating							
• with $I_L^{(1)}$	kW	630	710	900	630	710	1000
• with $I_H^{(1)}$	kW	500	560	710	560	630	800
• at I_L at 60 Hz 460 V or 575 V ²⁾	hp	900	1000	1250	900	1000	1250
• at I_H at 60 Hz 460 V or 575 V ²⁾	hp	700	900	1000	800	900	1000
Output current							
• Rated current $I_{rated}^{(8)}$	A	1120	1380	1560	860	1070	1360
• Base load current $I_L^{(3)(8)}$	A	1092	1340	1516	836	1036	1314
• Base load current $I_H^{(4)(8)}$	A	850	1054	1294	770	950	1216
Input current							
• Rated input current ^{5) 8)}	A	1174	1444	1624	904	1116	1424
• Input current, max.	A	1800	2215	2495	1388	1708	2186
• Current requirement, 24 V DC auxiliary power supply ⁶⁾	A	2.8	2.8	3.0	2.8	2.8	3.0
Power loss	kW	16.2	19.0	19.9	15.4	17.2	23.8
Cooling-air demand	m ³ /s	1.56	1.56	1.56	1.56	1.56	2.96
Sound pressure level L_{pA} (1 m) at 50/60 Hz	dB	73/76	73/76	73/76	75/78	75/78	75/78
Cable lengths between converter and motor ¹⁰⁾							
• shielded	m	300	300	300	300	300	300
• unshielded	m	450	450	450	450	450	450
Dimensions							
• Width ⁹⁾	mm	2400	2400	2400	2400	2400	3200
• Height ⁷⁾	mm	2000	2000	2000	2000	2000	2000
• Depth	mm	600	600	600	600	600	600
Weight (degree of protection IP20, without options), approx.	kg	1700	1710	2130	1700	1700	2620

Note: The power data in hp units are based on the NEC/CEC standards for the North American market.

Information on the line connection, motor connection and cabinet grounding is provided under

Cable cross-sections and connections.

1) Rated power of a typ. 6-pole standard induction motor based on I_L or I_H at 50 Hz 400 V, 500 V or 690 V 3 AC.

2) Rated power of a typ. 6-pole standard induction motor based on I_L or I_H at 60 Hz 460 V or 575 V 3 AC.

3) The base load current I_L is based on a duty cycle of 110 % for 60 s or 150 % for 10 s with a duty cycle duration of 300 s. See characteristic curves (→ Overload capability).

4) The base load current I_H is based on a duty cycle of 150 % for 60 s or 160 % for 10 s with a duty cycle duration of 300 s. See characteristic curves (→ Overload capability).

5) The current values given here are based on the rated output current.

6) If the drive control is to remain active after a main infeed failure, the converter must be externally supplied with 24 V DC.

The following should also be taken into account:

- CU320-2: 1 A
- TM31: 0.5 A
- AOP30: 0.2 A
- SMC: 0.6 A

– The current requirement of the digital inputs/outputs.

7) The cabinet height increases by 250 mm for degree of protection IP21, 400 mm for degrees of protection IP23, IP43 and IP54, 405 mm for options **M13** and **M78**.

8) The currents listed here represent the total current of both partial converters.

9) Power units connected in parallel are shipped as two transport units.

10) Longer cable lengths for specific configurations are available on request.

SINAMICS G150

Drive converter cabinet units

75 kW to 2700 kW

Technical data (continued)*Technical data for parallel circuit*

		SINAMICS G150 converter cabinet units, version A							
		6SL3710-2GH41-1AA3	6SL3710-2GH41-4AA3	6SL3710-2GH41-5AA3	6SL3710-2GH41-8EA3	6SL3710-2GH42-0EA3	6SL3710-2GH42-2EA3	6SL3710-2GH42-4EA3	6SL3710-2GH42-7EA3
Line voltage		660 ... 690 V 3 AC							
Type rating									
• with $I_L^{1)}$	kW	1000	1350	1500	1750	1950	2150	2400	2700
• with $I_H^{1)}$	kW	900	1200	1350	1500	1750	1950	2150	2400
• at I_L at 60 Hz 460 V or 575 V ²⁾	hp	–	–	–	–	–	–	–	–
• at I_H at 60 Hz 460 V or 575 V ²⁾	hp	–	–	–	–	–	–	–	–
Output current									
• Rated current $I_{rated}^{8)}$	A	1070	1360	1500	1729	1948	2158	2413	2752
• Base load current $I_L^{3)8)}$	A	1036	1314	1462	1720	1940	2150	2390	2685
• Base load current $I_H^{4)8)}$	A	950	1216	1340	1547	1742	1930	2158	2463
Input current									
• Rated input current ⁵⁾⁸⁾	A	1116	1424	1568	1800	2030	2245	2510	2865
• Input current, max.	A	1708	2186	2406	2765	3115	3450	3860	4400
• Current requirement, 24 V DC auxiliary power supply ⁶⁾	A	2.8	2.8	3.0	4.7	4.7	4.7	4.7	6
Power loss	kW	21.3	26.6	29.0	35	38	40	46	52
Cooling-air demand	m ³ /s	1.56	2.96	2.96	3.67	3.67	3.67	3.67	5.15
Sound pressure level L_{pA} (1 m) at 50/60 Hz	dB	75/78	75/78	75/78	75/78	75/78	75/78	75/78	75/78
Cable lengths between converter and motor ¹⁰⁾									
• shielded	m	300	300	300	300	300	300	300	300
• unshielded	m	450	450	450	450	450	450	450	450
Dimensions									
• Width ⁹⁾	mm	2400	3200	3200	3600	3600	3600	3600	4400
• Height ⁷⁾	mm	2000	2000	2000	2000	2000	2000	2000	2000
• Depth	mm	600	600	600	600	600	600	600	600
Weight (degree of protection IP20, without options), approx.	kg	1700	2620	2700	3010	3010	3070	3860	4580

Note: The power data in hp units are based on the NEC/CEC standards for the North American market.

Information on the line connection, motor connection and cabinet grounding is provided under

Cable cross-sections and connections.

¹⁾ Rated power of a typ. 6-pole standard induction motor based on I_L or I_H at 50 Hz 400 V, 500 V or 690 V 3 AC.

²⁾ Rated power of a typ. 6-pole standard induction motor based on I_L or I_H at 60 Hz 460 V or 575 V 3 AC.

³⁾ The base load current I_L is based on a duty cycle of 110 % for 60 s or 150 % for 10 s with a duty cycle duration of 300 s. See characteristic curves (→ Overload capability).

⁴⁾ The base load current I_H is based on a duty cycle of 150 % for 60 s or 160 % for 10 s with a duty cycle duration of 300 s. See characteristic curves (→ Overload capability).

⁵⁾ The current values given here are based on the rated output current.

⁶⁾ If the drive control is to remain active after a main infeed failure, the converter must be externally supplied with 24 V DC.

The following should also be taken into account:

- CU320-2: 1 A
- TM31: 0.5 A
- AOP30: 0.2 A
- SMC: 0.6 A

– The current requirement of the digital inputs/outputs.

⁷⁾ The cabinet height increases by 250 mm for degree of protection IP21, 400 mm for degrees of protection IP23, IP43 and IP54, 405 mm for options **M13** and **M78**.

⁸⁾ The currents listed here represent the total current of both partial converters.

⁹⁾ Power units connected in parallel are shipped as two transport units.

¹⁰⁾ Longer cable lengths for specific configurations are available on request.

Characteristic curves

Derating data

SINAMICS G150 converter cabinet units and the associated system components are rated for an ambient temperature of 40 °C and installation altitudes up to 2000 m above sea level.

For ambient temperatures > 40 °C the output current must be reduced. Ambient temperatures above 50 °C are not permissible.

At installation altitudes > 2000 m above sea level, it should be taken into consideration that with increasing height, the air pressure decreases and therefore the air density. As a consequence, the cooling efficiency and the insulation capacity of the air also decrease.

Due to the reduced cooling efficiency, it is necessary, on the one hand, to reduce the ambient temperature, and on the other hand, to lower heat loss in the converter cabinet unit by reducing the output current, whereby ambient temperatures lower than 40 °C may be offset to compensate.

The following table specifies the permissible output currents as a function of the installation altitude and ambient temperature for the various degrees of protection (the permissible compensation between installation altitude and the ambient temperatures < 40 °C – air intake temperature at the entry to the converter cabinet unit – has been taken into account in the specified values).

The values apply under the precondition that the cabinet layout ensures a cooling air flow through the units as stated in the technical data.

As additional measure for installation altitudes from 2000 m up to 5000 m, an isolating transformer is required in order to reduce transient overvoltages according to EN 60664-1. The SINAMICS Low Voltage Engineering Manual contains additional information on this topic and is available as a PDF file on the CD-ROM included with the catalog.

Degree of protection	Installation altitude above sea level m	Current derating factor (as a % of the rated current) at an ambient/intake air temperature of							
		20 °C	25 °C	30 °C	35 °C	40 °C	45 °C	50 °C	
IP20, IP21, IP23 and IP43	0 ... 2000						93.3 %	86.7 %	
	2001 ... 2500					96.3 %			
	2501 ... 3000		100 %		98.7 %				
	3001 ... 3500								
	3501 ... 4000			96.3 %					
	4001 ... 4500		97.5 %						
	4501 ... 5000	98.2 %							
IP54	0 ... 2000					93.3 %	86.7 %	80.0 %	
	2001 ... 2500		100 %		96.3 %	89.8 %			
	2501 ... 3000				98.7 %	92.5 %			
	3001 ... 3500			94.7 %					
	3501 ... 4000		96.3 %	90.7 %					
	4001 ... 4500	97.5 %	92.1 %						
	4501 ... 5000	93.0 %							

Current-derating factors for cabinet converter units as a function of the ambient/intake air temperature, the installation altitude and the degree of protection.

SINAMICS G150

Drive converter cabinet units

75 kW to 2700 kW

Characteristic curves (continued)

Current derating as a function of pulse frequency

To reduce motor noise or to increase output frequency, the pulse frequency can be increased relative to the factory setting. When the pulse frequency is increased, the derating factor of the output current must be taken into account. This derating factor must be applied to the currents specified in the technical data.

The SINAMICS Low Voltage Engineering Manual contains additional information and is available as a PDF file on the CD-ROM included with Catalog D 11.

Order No.	Type rating	Output current at 2 kHz A	Derating factor at pulse frequency	
	kW		2.5 kHz	4 kHz
380 ... 480 V 3 AC				
6SL3710-1GE32-1.A3	110	210	95 %	82 %
6SL3710-1GE32-6.A3	132	260	95 %	83 %
6SL3710-1GE33-1.A3	160	310	97 %	88 %
6SL3710-1GE33-8.A3	200	380	96 %	87 %
6SL3710-1GE35-0.A3	250	490	94 %	78 %

Derating factor of the output current as a function of the pulse frequency for units with a rated pulse frequency of 2 kHz

Order No.	Type rating	Output current at 1.25 kHz A	Derating factor at pulse frequency		
	kW		2.0 kHz	2.5 kHz	4 kHz
380 ... 480 V 3 AC					
6SL3710-1GE36-1.A3	315	605	83 %	72 %	64 %
6SL3710-1GE37-5.A3	400	745	83 %	72 %	64 %
6SL3710-1GE38-4.A3	450	840	87 %	79 %	64 %
6SL3710-1GE41-0.A3	560	985	92 %	87 %	70 %
6SL3710-2GE41-1AA3	630	1120	83 %	72 %	64 %
6SL3710-2GE41-4AA3	710	1380	83 %	72 %	64 %
6SL3710-2GE41-6AA3	900	1560	87 %	79 %	64 %
500 ... 600 V 3 AC					
6SL3710-1GF31-8.A3	110	175	92 %	87 %	70 %
6SL3710-1GF32-2.A3	132	215	92 %	87 %	70 %
6SL3710-1GF32-6.A3	160	260	92 %	88 %	71 %
6SL3710-1GF33-3.A3	200	330	89 %	82 %	65 %
6SL3710-1GF34-1.A3	250	410	89 %	82 %	65 %
6SL3710-1GF34-7.A3	315	465	92 %	87 %	67 %
6SL3710-1GF35-8.A3	400	575	91 %	85 %	64 %
6SL3710-1GF37-4.A3	500	735	87 %	79 %	64 %
6SL3710-1GF38-1.A3	560	810	83 %	72 %	61 %
6SL3710-2GF38-6AA3	630	860	92 %	87 %	67 %
6SL3710-2GF41-1AA3	710	1070	91 %	85 %	64 %
6SL3710-2GF41-4AA3	1000	1360	87 %	79 %	64 %

Derating factor of the output current as a function of the pulse frequency for units with a rated pulse frequency of 1.25 kHz

Characteristic curves (continued)

Order No.	Type rating	Output current at 1.25 kHz A	Derating factor at pulse frequency		
	kW		2.0 kHz	2.5 kHz	4 kHz
660 ... 690 V 3 AC					
6SL3710-1GH28-5.A3	75	85	93 %	89 %	71 %
6SL3710-1GH31-0.A3	90	100	92 %	88 %	71 %
6SL3710-1GH31-2.A3	110	120	92 %	88 %	71 %
6SL3710-1GH31-5.A3	132	150	90 %	84 %	66 %
6SL3710-1GH31-8.A3	160	175	92 %	87 %	70 %
6SL3710-1GH32-2.A3	200	215	92 %	87 %	70 %
6SL3710-1GH32-6.A3	250	260	92 %	88 %	71 %
6SL3710-1GH33-3.A3	315	330	89 %	82 %	65 %
6SL3710-1GH34-1.A3	400	410	89 %	82 %	65 %
6SL3710-1GH34-7.A3	450	465	92 %	87 %	67 %
6SL3710-1GH35-8.A3	560	575	91 %	85 %	64 %
6SL3710-1GH37-4.A3	710	735	87 %	79 %	64 %
6SL3710-1GH38-1.A3	800	810	83 %	72 %	61 %
6SL3710-2GH41-1AA3	1000	1070	91 %	85 %	64 %
6SL3710-2GH41-4AA3	1350	1360	87 %	79 %	64 %
6SL3710-2GH41-5AA3	1500	1500	83 %	72 %	61 %
6SL3710-2GH41-8EA3	1750	1729	92 %	87 %	67 %
6SL3710-2GH42-0EA3	1950	1948	91 %	86 %	64 %
6SL3710-2GH42-2EA3	2150	2158	87 %	79 %	55 %
6SL3710-2GH42-4EA3	2400	2413	87 %	79 %	55 %
6SL3710-2GH42-7EA3	2700	2752	91 %	86 %	64 %

Derating factor of the output current as a function of the pulse frequency for units with a rated pulse frequency of 1.25 kHz

SINAMICS G150

Drive converter cabinet units

75 kW to 2700 kW

Characteristic curves (continued)

Overload capability

The SINAMICS G150 drive converter cabinet units are equipped with an overload reserve to deal with breakaway torques, for example. If larger surge loads occur, this must be taken into account when configuring. In the case of drives with overload requirements, the appropriate base load current must, therefore, be used as a basis for the required load.

The criterion for overload is that the drive is operated with its base-load current before and after the overload occurs on the basis of a duty cycle duration of 300 s.

The base load current I_L for a small overload is based on a duty cycle of 110 % for 60 s or 150 % for 10 s.

The base load current for a high overload I_H is based on a duty cycle of 150 % for 60 s or 160 % for 10 s.

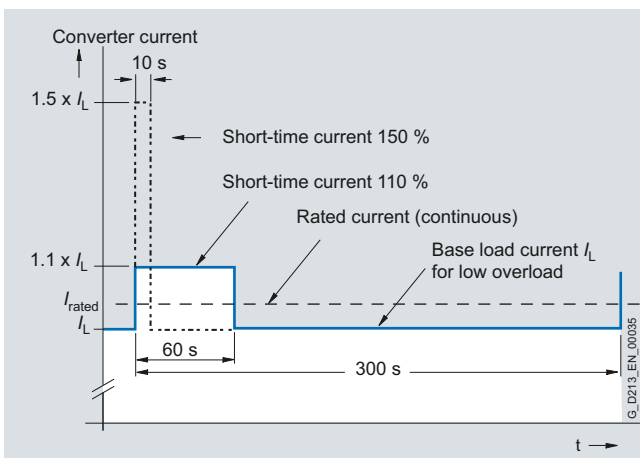

Low overload

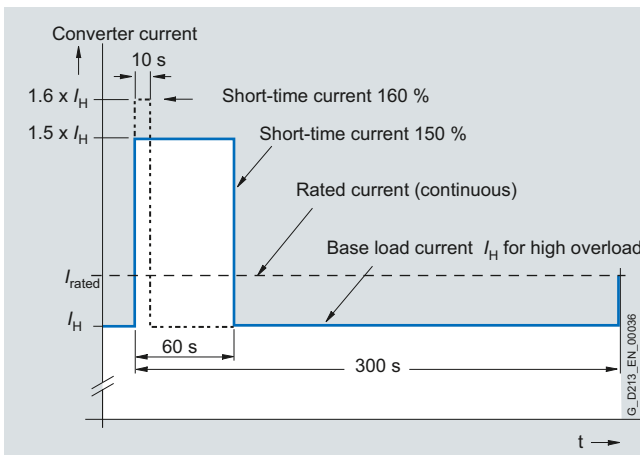

High overload

SINAMICS G150

Drive converter cabinet units

75 kW to 2700 kW

Options

Note: To order options for a converter, add the suffix "-Z" after the order number of the converter and then state the order code(s) for the desired option(s) after the suffix.

Example:
6SL3710-1GE32-1CA3-Z
+M07+D60+...

See also ordering examples.

Available options	Order code	for version A	for version C
Input-side options			
Use in the first environment to EN 61800-3 Category C2 (TN systems or TT systems with grounded star point) ⁴⁾	L00	✓	–
Clean Power version with integrated Line Harmonics Filter compact ³⁾	L01	✓	–
Line contactor (for currents ≤ 800 A for single circuit)	L13	✓	–
Delivery without line reactor (for converters ≤ 500 kW)	L22	✓	✓
Line reactor $v_k = 2\%$ (for converters > 500 kW)	L23	✓	✓
Main switch incl. fuses/circuit breakers	L26	✓	–
EMC shield busbar ¹⁾ (cable connection from below)	M70	✓	✓
Load-side options			
dv/dt filter compact plus Voltage Peak Limiter	L07	✓	–
Motor reactor	L08	✓	–
dv/dt filter plus Voltage Peak Limiter ³⁾	L10	✓	–
Sine-wave filter (up to 250 kW at 380 ... 480 V, up to 132 kW at 500 ... 600 V)	L15	✓	–
EMC shield busbar ¹⁾ (cable connection from below)	M70	✓	✓
Motor protection and safety functions			
EMERGENCY OFF pushbutton, door mounted	L45	✓	–
EMERGENCY OFF Category 0, 230 V AC or 24 V DC	L57	✓	–
EMERGENCY STOP Category 1, 230 V AC ²⁾	L59	✓	–
EMERGENCY STOP Category 1, 24 V DC ²⁾	L60	✓	–
Thermistor motor protection unit (alarm)	L83	✓	–
Thermistor motor protection unit (shutdown)	L84	✓	–
PT100 evaluation unit	L86	✓	–
Insulation monitoring	L87	✓	–
Increase in degree of protection			
Degree of protection IP21	M21	✓	✓
Degree of protection IP23	M23	✓	✓
Degree of protection IP43	M43	✓	✓
Degree of protection IP54	M54	✓	✓
Mechanical options			
Base 100 mm high, RAL 7022	M06	✓	✓
Cable plinth 200 mm high, RAL 7035	M07	✓	✓
Top cable entry, line side ³⁾	M13	✓	–
Top cable entry, motor side ³⁾	M78	✓	–
Crane transport assembly (top-mounted)	M90	✓	✓

✓	possible
–	not possible

- ¹⁾ This option is listed for the input- and load-side options, but is only required once.
- ²⁾ The stopping requirements must be taken into account with this option. Additional braking units may be required.
- ³⁾ Not available for converters > 1500 kW with power units connected in parallel.
- ⁴⁾ Applies to cable lengths < 100 m.

Please refer to the selection matrix for information about possible option combinations.

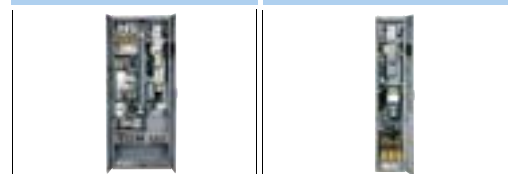

Converter version A

Converter version C

SINAMICS G150

Drive converter cabinet units

75 kW to 2700 kW

Options (continued)

Available options	Order code	for version A	for version C
Other options			
CBC10 Communication Board (CAN protocol)	G20	✓	✓
CBE20 Communication Board (PROFINET)	G33	✓	✓
TM31 customer Terminal Module	G60	✓	✓
Additional TM31 customer Terminal Module	G61	✓	–
TB30 Terminal Board	G62	✓	✓
SMC30 Sensor Module Cabinet-Mounted	K50	✓	✓
VSM10 Voltage Sensing Module Cabinet-Mounted	K51	✓	–
Terminal interface for "Safe Torque Off" and "Safe Stop 1" safety functions	K82	✓	–
Control Unit Kit CU320-2 PN (PROFINET)	K95	✓	–
Connection for external auxiliary equipment	L19	✓	–
Cabinet light with service socket	L50	✓	–
Cabinet anti-condensation heating	L55	✓	✓
Braking unit 25 kW (P_{20} power: 100 kW)	L61	✓	–
Braking unit 50 kW (P_{20} power: 200 kW)	L62	✓	–
Special cabinet paint finish ¹⁾	Y09	✓	✓
Documentation (standard: English/German)			
Customer documentation (circuit diagram, terminal diagram, layout diagram) in DXF format	D02	✓	✓
Customer documentation in paper format	D04	✓	✓
Preliminary copy of customer documentation	D14	✓	✓
Documentation language: English/French	D58	✓	✓
Documentation language: English/Spanish	D60	✓	✓
Documentation language: English/Italian	D80	✓	✓
Languages (standard: English/German)			
Rating plate data in English/French	T58	✓	✓
Rating plate data in English/Spanish	T60	✓	✓
Rating plate data in English/Italian	T80	✓	✓
Options specific to the chemical industry			
NAMUR terminal block	B00	✓	–
Safety isolated 24 V power supply (PELV)	B02	✓	–
Separate output for external auxiliaries (uncontrolled)	B03	✓	–
Options specific to the shipbuilding industry			
Marine version	M66	✓	✓
Individual certificate from Germanische Lloyd (GL)	E11	✓	✓
Individual certificate from Lloyds Register (LR)	E21	✓	✓
Individual certificate from Bureau Veritas (BV)	E31	✓	✓
Individual certificate from Det Norske Veritas (DNV)	E51	✓	✓
Individual certificate from American Bureau of Shipping (ABS)	E61	✓	✓
Individual certificate from Chinese Classification Society (CCS)	E71	✓	✓

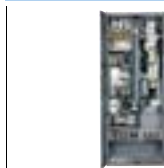

Converter version A

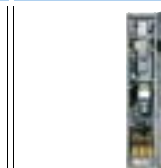

Converter version C

✓	possible
–	not possible

¹⁾ The order code Y.. requires data in plain text.

Please refer to the selection matrix for information about possible option combinations.

SINAMICS G150

Drive converter cabinet units

75 kW to 2700 kW

Options (continued)

Available options	Order code	for version A	for version C
Equipment acceptance in presence of customer			
Visual inspection	F03	✓	✓
Function test without connected motor	F71	✓	✓
Function test with test bay motor under no load conditions	F75	✓	✓
Insulation test (in conjunction with option F71 or F75)	F77	✓	✓
Customer-specific acceptance tests (on request)	F97	✓	✓

✓	possible
–	not possible

Please refer to the selection matrix for information about possible option combinations.



Converter version A

Converter version C

Option selection matrix

Certain options are mutually exclusive. The tables below only provide an overview. Please refer to the descriptions of the individual options for a precise description of options and other exclusions.

✓	Possible combination
–	Combination not possible

Electrical options

	G20	G33	G62	K50	K51	L00	L01	L13	L22	L23	L26	L57	L59	L60	L61	L62	L87
G20	–	–	–	✓	✓	✓	✓	✓	✓	✓	✓	✓	✓	✓	✓	✓	✓
G33	–	–	–	✓	✓	✓	✓	✓	✓	✓	✓	✓	✓	✓	✓	✓	✓
G62	–	–	–	✓	✓	✓	✓	✓	✓	✓	✓	✓	✓	✓	✓	✓	✓
K50	✓	✓	✓	–	–	✓	✓	✓	✓	✓	✓	✓	✓	✓	✓	✓	✓
K51	✓	✓	✓	–	–	✓	✓	✓	✓	✓	✓	✓	✓	✓	✓	✓	✓
L00	✓	✓	✓	✓	✓	–	✓	✓	–	1)	✓	✓	✓	✓	✓	✓	–
L01	✓	✓	✓	✓	✓	✓	–	✓	–	–	✓	✓	✓	✓	✓	✓	✓
L13	✓	✓	✓	✓	✓	✓	✓	–	✓	✓	2)	3)	3)	3)	✓	✓	✓
L22	✓	✓	✓	✓	✓	–	–	✓	–	–	✓	✓	✓	✓	✓	✓	✓
L23	✓	✓	✓	✓	✓	1)	–	✓	–	–	✓	✓	✓	✓	✓	✓	✓
L26	✓	✓	✓	✓	✓	✓	✓	2)	✓	✓	–	3)	3)	3)	✓	✓	✓
L57	✓	✓	✓	✓	✓	✓	✓	3)	✓	✓	3)	–	–	–	✓	✓	✓
L59	✓	✓	✓	✓	✓	✓	✓	3)	✓	✓	3)	–	–	–	✓	✓	✓
L60	✓	✓	✓	✓	✓	✓	✓	3)	✓	✓	3)	–	–	–	✓	✓	✓
L61	✓	✓	✓	✓	✓	✓	✓	✓	✓	✓	✓	✓	✓	✓	–	–	✓
L62	✓	✓	✓	✓	✓	✓	✓	✓	✓	✓	✓	✓	✓	✓	–	–	✓
L87	✓	✓	✓	✓	✓	–	✓	✓	✓	✓	✓	✓	✓	✓	✓	✓	–

1) For converters ≤ 500 kW / 700 hp, the line reactor (order code **L23**) is included in the scope of supply of the converter. For converters > 500 kW / 700 hp, option **L23** must be additionally ordered, if

- the converters are operated on line supplies with a high short-circuit power ($R_{SC} > 20$), or
- when using a line filter (option **L00**).

2) Combination **L13/L26** only possible for currents < 800 A. From 800 A and higher, circuit breakers are used that also include the function of **L13** and **L26**.

3) The options **L57**, **L59** and **L60** always require electrical separation from the line supply, this means for converters in a single circuit, for converter currents ≤ 800 A, option **L13** and for converter currents > 800 A, option **L26**. For converters with power units connected in parallel, electrical separation from the line supply is included as standard.

SINAMICS G150

Drive converter cabinet units

75 kW to 2700 kW

Options (continued)

Mechanical options/electrical options

	E11	E21	E31	E51	E61	E71	L00	L01	L07	L08	L10	L15	M06	M07	M13	M21	M23	M43	M54	M66	M70	M78	
E11	✓	✓	✓	✓	✓	✓	✓	–	✓	✓	✓	✓	✓	✓	✓	–	3)	✓	✓	✓	✓	✓	✓
E21	✓	–	✓	✓	✓	✓	✓	–	✓	✓	✓	✓	✓	✓	✓	–	3)	✓	✓	✓	✓	✓	✓
E31	✓	✓	–	✓	✓	✓	✓	–	✓	✓	✓	✓	✓	✓	✓	–	3)	✓	✓	✓	✓	✓	✓
E51	✓	✓	✓	–	✓	✓	✓	–	✓	✓	✓	✓	✓	✓	✓	–	3)	✓	✓	✓	✓	✓	✓
E61	✓	✓	✓	✓	–	✓	✓	–	✓	✓	✓	✓	✓	✓	✓	–	3)	✓	✓	✓	✓	✓	✓
E71	✓	✓	✓	✓	✓	–	✓	–	✓	✓	✓	✓	✓	✓	✓	–	3)	✓	✓	✓	✓	✓	✓
L00	✓	✓	✓	✓	✓	✓	–	✓	✓	✓	✓	✓	✓	✓	✓	✓	✓	✓	✓	✓	✓	1)	✓
L01	–	–	–	–	–	–	✓	–	✓	✓	✓	✓	✓	✓	✓	✓	✓	✓	✓	✓	✓	–	✓
L07	✓	✓	✓	✓	✓	✓	✓	✓	–	–	–	–	✓	✓	✓	✓	✓	✓	✓	✓	✓	✓	–
L08	✓	✓	✓	✓	✓	✓	✓	✓	–	–	–	–	✓	✓	✓	✓	✓	✓	✓	✓	✓	✓	–
L10	✓	✓	✓	✓	✓	✓	✓	✓	–	–	–	–	✓	✓	✓	✓	✓	✓	✓	✓	✓	✓	–
L15	✓	✓	✓	✓	✓	✓	✓	✓	–	–	–	–	✓	✓	✓	✓	✓	✓	✓	✓	✓	✓	–
M06	✓	✓	✓	✓	✓	✓	✓	✓	✓	✓	✓	✓	–	–	✓	✓	✓	✓	✓	✓	✓	✓	✓
M07	✓	✓	✓	✓	✓	✓	✓	✓	✓	✓	✓	✓	–	–	✓	✓	✓	✓	✓	✓	✓	✓	✓
M13	✓	✓	✓	✓	✓	✓	✓	✓	✓	✓	✓	✓	✓	✓	–	–	✓	✓	✓	✓	✓	2)	✓
M21	–	–	–	–	–	–	✓	✓	✓	✓	✓	✓	✓	✓	–	–	–	–	–	–	–	✓	–
M23	3)	3)	3)	3)	3)	3)	✓	✓	✓	✓	✓	✓	✓	✓	✓	–	–	–	–	–	3)	✓	✓
M43	✓	✓	✓	✓	✓	✓	✓	✓	✓	✓	✓	✓	✓	✓	✓	–	–	–	–	–	✓	✓	✓
M54	✓	✓	✓	✓	✓	✓	✓	✓	✓	✓	✓	✓	✓	✓	✓	–	–	–	–	–	✓	✓	✓
M66	✓	✓	✓	✓	✓	✓	✓	–	✓	✓	✓	✓	✓	✓	✓	–	3)	✓	✓	–	✓	✓	✓
M70	✓	✓	✓	✓	✓	✓	1)	✓	✓	✓	✓	✓	✓	✓	2)	✓	✓	✓	✓	✓	✓	–	2)
M78	✓	✓	✓	✓	✓	✓	✓	✓	–	–	–	–	✓	✓	✓	–	✓	✓	✓	✓	✓	2)	–

1) Option L00 includes option M70.

2) If the line connection (option M13) and the motor connection (option M78) are from above, then the EMC shield busbar (option M70) and the PE busbar (option M75) are not required in the bottom section of the cabinet.

3) Option M66 includes option M23.

Rating plate data

	T58	T60	T80
T58	–	–	–
T60	–	–	–
T80	–	–	–

Ordering examples

Example 1

Task:

A drive converter cabinet unit is needed to control the fan speed for a 380 kW fan drive connected to an existing 400 V MCC outgoing circuit. The rated speed of the fan is 975 rpm. Due to the prevailing ambient conditions, the converter must be mounted on a 100 mm cabinet base and have IP54 degree of protection. The installation altitude is <1000 m above sea level, the ambient temperature is 45 °C.

Solution:

Because an MCC outgoing circuit already exists, the line connection components, such as main switch, line contactor and line fuses, can be omitted and the space-saving version C can be selected. If we take into account the derating factors for IP54 degree of protection and the increased ambient temperature, a 450 kW, 400 V drive converter cabinet unit with options M06 (cabinet base 100 mm) and M54 (IP54 degree of protection) must be selected for this application.

The information to be stated on the order is therefore:

6SL3710-1GE38-4CA3-Z
+M06 +M54

Example 2

Task:

A 280 kW pump to control pressure compensation is to be supplied via a converter for a completely new district heating pumping station. A 690 V supply is available. The installation altitude is 350 m above sea level and the ambient temperature is 40 °C. The rated speed of the pump is 740 rpm. The pump unit and motor are located in an unmanned substation, so the winding temperature of the motor must be monitored by PT100 resistance thermometers and evaluated by the converter. The color of the drive converter cabinet units is to be RAL 3002.

Solution:

A converter cabinet unit with 315 kW, 690 V in the version A with the following options should be selected:

L26 (main switch including fuses),
L13 (line contactor),
L86 (PT100 evaluation unit) and
Y09 (special cabinet paint finish).

The ordering data are therefore:

6SL3710-1GH33-3AA3-Z
+L26 +L13 +L86 +Y09
cabinet color RAL 3002

Options (continued)

Description of options

The SINAMICS Low Voltage Engineering Manual contains additional information about the options and is saved as PDF file on the CD-ROM included with the catalog.

B00, B02, B03

Options compliant with NAMUR requirements

List of impermissible combinations with other options:

The following restrictions and exclusions applicable to the NAMUR terminal block **B00** in relation to other available options must be taken into account.

Comment on the option	Reason
L45, L57, L59, L60	A Category 0 EMERGENCY OFF is already provided in the NAMUR version. The forced power supply disconnection is accessed at terminals -A1-X2: 17, 18.
L83, L84	The option B00 already provides a thermistor motor protection unit (shutdown) as standard.
L19	The combination of option L19 and B00 is possible on request.
L87	For space reasons, the insulation monitor cannot be installed in the cabinet and must therefore be provided on the plant side.
G60	Option B00 already provides a customer Terminal Module TM31 as standard.

With options such as **L50, L55, L86**, the connection is made as standard. These options are not wired to the NAMUR terminal block.

Notice: In addition to option **B00** for line separation, option **L13** for currents ≤ 800 A or option **L26** for currents > 800 A must be ordered. For converters with power units connected in parallel, electrical separation from the line supply is included as standard. Further, to evaluate the signals, option **G60** must be ordered.

B00

NAMUR terminal block

The terminal block has been designed and implemented in accordance with the requirements and guidelines of the Standards Working Group for Instrumentation and Control in the Chemical Industry (NAMUR Recommendation NE37), i.e. certain functions of the device are assigned to specified terminals. The inputs and outputs assigned to the terminals fulfill PELV requirements ("protective extra-low voltage and protective separation").

The terminal block and associated functions have been reduced to the necessary minimum. Unlike the NAMUR recommendation, optional terminals are not listed.

Terminal -A1-X2:	Meaning	Default	Comment
10	DI	ON (dynamic)/ ON/OFF (static)	The effective mode can be encoded using a wire jumper at terminal -A1-400:9; 10.
11	DI	OFF (dynamic)	
12	DI	Faster	
13	DI	Slower	
14	DI	RESET	
15	DI	Interlock	
16	DI	Counterclockwise	"0" signal for CW rotating field "1" signal for CCW rotating field
17, 18		Supply disconnection	EMERGENCY OFF circuit
30, 31		Ready	Relay output (NO contact)
32, 33		Motor is rotating	Relay output (NO contact)
34	DO (NO)	Fault	Relay output (changeover contact)
35	DO (COM)		
36	DO (NC)		
50, 51	AI 0/4-20 mA	Speed setpoint	
60, 61	AO 0/4-20 mA	Motor frequency	
62, 63	AO 0/4-20 mA	Motor current	Motor current is default setting; can be reparameterized for other variables

The 24 V supply is provided on the plant side via terminals -A1-X2:1-3 (fused in the converter with 1 A). Compliance with the PELV safety requirements ("Protective extra-low voltage with protective separation") is essential.

Terminal -A1-X2:	Meaning	
1	M	Reference conductor
2	P24	24 V DC supply
3	P24	24 V DC outgoing circuit

For temperature monitoring of explosion-proof motors, option **B00** includes a PTC thermistor tripping unit. Violation of the limit value leads to motor shutdown. The associated PTC sensor is connected to terminal -A1-X3:90, 91.

Terminal -A1-X3:	Meaning	
90, 91	AI	Connection of PTC sensor

In parallel to operation via the NAMUR terminal block, there is also the option to operate the converter via the communications interface provided as standard on the CU320-2 Control Unit. The PROFIdrive profile "Process technology" employed in the chemical industry can be selected by macros.

SINAMICS G150

Drive converter cabinet units

75 kW to 2700 kW

Options (continued)

B02 *Safety isolated 24 V power supply (PELV)*

If no protective separation for 24 V supply (PELV) is available at the customer site, this option is used to fit a second power supply to guarantee compliance with PELV. (Terminal assignments as for option **B00**, no 24 V supply at terminals -A1-X1:1, 2, 3)

Notice: The option **B02** is only possible in combination with **B00**.

B03 *Separate output for external auxiliaries (uncontrolled)*

If, for example, a motor fan is to be supplied with power from the plant, option **B03** provides an external outgoing feeder with a 10 A fuse. As soon as the supply voltage is present at the converter input, a voltage corresponding to the converter input voltage ($V = V_{line}$) is also present at these terminals. This must be taken into consideration for the configuring of external fans.

Terminal	Meaning
-A1-X1:	

1, 2, 3, PE	Outgoing circuit for external auxiliaries
--------------------	---

Notice: Option **B03** is only possible in combination with **B00**.

D02 *Customer documentation (circuit diagram, terminal diagram, layout diagram) in the DXF format*

This option can be used to order documents such as circuit diagrams, terminal diagrams, layout diagrams, and dimension drawings in DXF format, in order to process them further in CAD systems, for example. They are supplied on the documentation CD in the desired language (standard is English/German, for other languages, see options **D58**, **D60**, **D80**).

D04 *Customer documentation in paper format*

Equipment documentation is supplied electronically on CD-ROM as standard. If the customer also requires a hard copy of the documentation and selects option **D04**, the following documents will be provided in a folder together with the drive converter:

- Operating instructions
- Circuit diagram
- Terminal diagram
- Layout diagram
- Dimension drawing
- Spare parts list
- Test certificate

Regardless of whether option **D04** is selected, a hard copy of the safety and transportation guidelines, a check list and a registration form is always supplied.

D14 *Preliminary copy of customer documentation*

If documents such as circuit diagrams, terminal diagrams, layout diagrams and dimension drawings are required in advance for system engineering, a preliminary copy of the relevant documentation can be ordered with the converter. These documents are then supplied electronically a few working days after the order has been recorded. The system-specific documentation is supplied to the customer via e-mail in the desired language (standard is English/German, for other languages, see options **D58**, **D60**, **D80**). The recipient's e-mail address must be provided with the order for this purpose. If option **D02** is selected at the same time, the documents are provided in the DXF format, otherwise they are sent in PDF format. In the e-mail, the recipient is also provided with a link for downloading general preliminary documentation such as operating instructions, manual and commissioning guide.

D58/D60/D80 *Documentation language*

Order code	Language
D58	English/French
D60	English/Spanish
D80	English/Italian

E11 to E71 *Individual certification of the converter*

The individual certification of the converter by the relevant certification body contains the expansions described for option **M66**.

E11 Individual certificate from Germanische Lloyd (GL)

E21 Individual certificate from Lloyds Register (LR)

E31 Individual certificate from Bureau Veritas (BV)

E51 Individual certificate from Det Norske Veritas (DNV)

E61 Individual certificate from American Bureau of Shipping (ABS)

E71 Individual certificate from Chinese Classification Society (CCS)

Note: A combination of several individual certificates is not available.

Options (continued)

F03, F71, F75, F77, F97

Equipment acceptance in presence of customer

Order code	Description	
F03	Visual inspection	<p>The acceptance scope includes:</p> <ul style="list-style-type: none"> • Checking the degree of protection • Checking the equipment (components) • Checking the equipment identifiers • Checking the clearance and creepage distances • Checking the cables • Checking the customer documentation • Submission of the acceptance report <p>All the above checks are performed with the converter isolated from the power supply.</p>
F71	Function test without connected motor	<p>The acceptance scope includes:</p> <ul style="list-style-type: none"> • Visual inspection as described for option F03 • Checking the power supply • Checking the protective and monitoring devices (simulation) • Checking the fans • Precharging test • Function test without connected motor • Submission of the acceptance report <p>After the visual inspection with the converter switched off, the converter is connected to rated voltage. No current at the converter output end.</p>
F75	Function test with test bay motor under no load conditions	<p>The acceptance scope includes:</p> <ul style="list-style-type: none"> • Visual inspection as described for option F03 • Checking the power supply • Checking the protective and monitoring devices (simulation) • Checking the fans • Precharging test • Function test with test bay motor (no load) • Submission of the acceptance report <p>After the visual inspection with the converter switched off, the converter is connected to rated voltage.</p> <p>A small current flows at the converter's output in order to operate the test bay motor (no load).</p>
F77	Insulation test	<p>The acceptance scope includes:</p> <ul style="list-style-type: none"> • High-voltage test • Insulation resistance measurement
F97	Customer-specific acceptance tests (on request)	<p>If acceptance tests are desired which are not covered by the options F03, F71, F75 or F77, customized acceptances/supplementary tests can be ordered using order code F97 on request and following technical clarification.</p>

G20 CBC10 Communication Board

The CBC10 Communication Board is used to interface the CU320-2 Control Unit and thus the SINAMICS G150 to the CAN (Controller Area Network) protocol. The board's driver software fulfills the standards of the following CANopen specification of the CiA organization (CAN in Automation):

- Communication profiles in accordance with DS 301
- Drive profile in accordance with DSP 402 (in this case Profile Velocity Mode)

- EDS (Electronic Data Sheet) in accordance with DSP 306
- Operational status signaling in accordance with DSP 305

The CBC10 Communication Board plugs into the option slot on the CU320-2 Control Unit. Die CAN interface on the CBC10 has 2 SUB-D connections for input and output.

G33 CBE20 Communication Board

The CBE20 Communication Board is required, if

- a SINAMICS G130 or G150 converter, equipped with a Control Unit CU320-2 DP (PROFIBUS), is to be connected to a PROFINET-IO network,
- SINAMICS Link is to be used to directly exchange data between several Control Units CU320-2 DP (PROFIBUS) or CU320-2 PN (PROFINET) without using a higher-level control system.

With the CBE20 Communication Board, SINAMICS G130 or G150 then assumes the function of a PROFINET IO device in the sense of PROFINET and can perform the following functions:

- PROFINET IO device
- 100 Mbit/s full duplex
- Supports real-time classes of PROFINET IO:
 - RT (Real-Time)
 - IRT (Isochronous Real-Time), minimum send cycle 500 µs
- Connects to controls as a PROFINET IO device according to the PROFIdrive profile
- Standard TCP/IP communication for engineering processes using the STARTER commissioning tool
- Integrated 4-port switch with four RJ45-B sockets based on the PROFINET ASIC ERTEC400. The optimum topology (line, star, tree) can therefore be configured without additional external switches.

The CBE20 Communication Board plugs into the option slot on the CU320-2 Control Unit.

G60 TM31 customer Terminal Module

Terminal Module TM31 is used to extend the customer terminals on the CU320-2 Control Unit.

This provides the following additional interfaces:

- 8 digital inputs
- 4 bidirectional digital inputs/outputs
- 2 relay outputs with changeover contact
- 2 analog inputs
- 2 analog outputs
- 1 temperature sensor input (KTY84-130/PTC)
- 2 DRIVE-CLiQ sockets
- 1 connection for the electronics power supply via the 24 V DC supply connector
- 1 PE/protective conductor connection

To simplify configuration and commissioning of the drive, the optional TM31 Terminal Module can already be preset to a variety of factory settings, which can then be selected during commissioning.

The SINAMICS Low Voltage Engineering Manual contains additional information and is available as a PDF file on the CD-ROM included with Catalog D 11.

SINAMICS G150

Drive converter cabinet units

75 kW to 2700 kW

Options (continued)

G61

Additional TM31 customer Terminal Module

Using option **G61** the number of existing digital inputs/digital outputs, as well as the number of analog inputs/analog outputs within the drive system can be extended using a second TM31 Terminal Module (in addition to the TM31 Terminal Module that can be selected using option **G60**).

Note: Option **G61** requires option **G60**!

G62

TB30 Terminal Board

The TB30 Terminal Board is inserted into the option slot of the Control Unit and offers the possibility of expanding the Control Unit CU320-2 by 4 digital inputs/outputs as well as 2 analog inputs/outputs (see Chapter 2, "Supplementary system components").

Note: Option **G62** cannot be combined with options **G20** (CBC10 Communication Board) or **G33** (CBE20 Communication Board)!

K50

SMC30 Sensor Module Cabinet-Mounted

The SMC30 Sensor Module Cabinet-Mounted can be used to evaluate the encoders of motors without a DRIVE-CLiQ interface. External encoders can also be connected via the SMC30.

The following encoder signals can be evaluated:

- Incremental encoders TTL/HTL with and without open-circuit detection (open-circuit detection is only available with bipolar signals)
- SSI encoder with TTL/HTL incremental signals
- SSI encoder without incremental signals

The motor temperature can also be detected using KTY84-130, or PTC thermistors.

K51

VSM10 Voltage Sensing Module Cabinet-Mounted

The VSM10 Voltage Sensing Module is used to sense the voltage characteristic on the motor side so that the following function can be implemented:

- Operation of a permanent-magnet synchronous motor without encoder with the requirement to be able to connect to a motor that is already running ("Flying restart" function).

K82

Terminal interface for "Safe Torque Off" and "Safe Stop 1" safety functions

The terminal interface is used to control the "Basic Safety Functions" with isolation

- "Safe Torque Off" (STO) and
- "Safe Stop 1" (SS1) (time-controlled)

over a wide voltage range from DC/AC 24 V to 240 V (terminology according to Draft IEC 61800-5-2).

As a consequence, the "STO" and "SS1" safety functions can be flexibly controlled from the plant or system signal voltages.

The integrated safety functions, starting from the Safety Integrated (SI) input terminals of the components (Control Unit and Power Module), satisfy the requirements of EN 61800-5-2, EN 60204-1, DIN EN ISO 13849-1 Category 3 (formerly EN 954-1) for Performance Level (PL) d and IEC 61508 SIL 2.

With option **K82**, the requirements specified in EN 61800-5-2, EN 60204-1, DIN EN ISO 13849-1 Category 3 (formerly EN 954-1) for Performance Level (PL) d and IEC 61508 SIL 2 are fulfilled.

The Safety Integrated functions using option **K82** are only available in conjunction with certified components and software versions.

The Safety Integrated functions of SINAMICS are generally certified by independent institutes. An up-to-date list of certified components is available on request from your local Siemens office.

K95

Control Unit CU320-2 PN (PROFINET)

Instead of Control Unit CU320-2 DP (PROFIBUS) supplied as standard, the converter is supplied with a CU320-2 PN (PROFINET). Detailed information about this Control Unit (→ Converter chassis units).

L00

Use in the first environment to EN 61800-3 Category C2 (TN systems or TT systems with grounded star point)

To limit the **emitted interference**, the drive converters are equipped as standard with a radio interference suppression filter that conforms to the limits defined in Category C3. SINAMICS G150 converters equipped with the line filter also meet the limits for use in the first environment (Category C2) as specified in EN 61800-3. ¹⁾

The SINAMICS G150 units comply as standard with the **interference immunity** requirements defined in this standard for the first and second environments.

In conjunction with line reactors, line filters also limit the conducted interference emitted by the Power Modules to the limit values of Category C2 defined in product standard EN 61800-3. For converter power ratings > 500 kW, option **L23** must be additionally ordered (not required when option **L01** is selected).

To allow the power cable shield to be connected in conformance with EMC requirements, an additional EMC shield busbar (**M70** option) is factory fitted at the converter input and output. A separate order is not required in this case.

¹⁾ Applies to cable lengths < 100 m.

Options (continued)

L01

Clean Power version with integrated Line Harmonics Filter compact



Instead of the line reactor, an innovative LHF is integrated in the control cabinet; this minimizes the harmonics that occur due to the principle of operation. As a consequence, the unit fully complies with the limit values stipulated in standard IEEE 519-1992 without any exceptions (precondition: $v_k \leq 5\%$ or $RSC \geq 20$).

Option **L01** always requires electrical separation from the line supply, i.e. for converters in a single circuit for converter currents ≤ 800 A, option **L13** and for converter currents > 800 A, option **L26**. For converters with power units connected in parallel, electrical separation from the line supply is included as standard.

SINAMICS G150 Clean Power with integrated Line Harmonics Filter is available for power ratings up to 1500 kW in all available degrees of protection up to IP54 (→ Options **M21** to **M54**).

Notice: When using option **L01** on 60 Hz line supplies, then a restricted voltage tolerance of +8 % applies!

Note: Option **L01** cannot be combined with options **L22** (without line reactor), **L23** (line reactor $v_k = 2\%$) and **M66** (marine version).

Width and weight of the converter cabinet units
SINAMICS G150 Clean Power

Order number	Type rating	Width	Weight
Z = +L01	kW	mm	kg
380 ... 480 V 3 AC			
6SL3710-1GE32-1AA3-Z	110	1200	540
6SL3710-1GE32-6AA3-Z	132	1200	540
6SL3710-1GE33-1AA3-Z	160	1200	640
6SL3710-1GE33-8AA3-Z	200	1400	730
6SL3710-1GE35-0AA3-Z	250	1400	770
6SL3710-1GE36-1AA3-Z	315	1800	1300
6SL3710-1GE37-5AA3-Z	400	1800	1345
6SL3710-1GE38-4AA3-Z	450	1800	1555
6SL3710-1GE41-0AA3-Z	560	2200	1840
6SL3710-2GE41-1AA3-Z	630	3600	2580
6SL3710-2GE41-4AA3-Z	710	3600	2670
6SL3710-2GE41-6AA3-Z	900	3600	3090
500 ... 600 V 3 AC			
6SL3710-1GF31-8AA3-Z	110	1200	670
6SL3710-1GF32-2AA3-Z	132	1200	670
6SL3710-1GF32-6AA3-Z	160	1200	710
6SL3710-1GF33-3AA3-Z	200	1200	710
6SL3710-1GF34-1AA3-Z	250	1800	1340
6SL3710-1GF34-7AA3-Z	315	1800	1340
6SL3710-1GF35-8AA3-Z	400	1800	1340
6SL3710-1GF37-4AA3-Z	500	2200	2000
6SL3710-1GF38-1AA3-Z	560	2200	2040
6SL3710-2GF38-6AA3-Z	630	3600	2660
6SL3710-2GF41-1AA3-Z	710	3600	2660
6SL3710-2GF41-4AA3-Z	1000	4400	3980
660 ... 690 V 3 AC			
6SL3710-1GH28-5AA3-Z	75	1200	550
6SL3710-1GH31-0AA3-Z	90	1200	550
6SL3710-1GH31-2AA3-Z	110	1200	550
6SL3710-1GH31-5AA3-Z	132	1200	550
6SL3710-1GH31-8AA3-Z	160	1200	670
6SL3710-1GH32-2AA3-Z	200	1200	670
6SL3710-1GH32-6AA3-Z	250	1200	710
6SL3710-1GH33-3AA3-Z	315	1200	710
6SL3710-1GH34-1AA3-Z	400	1800	1340
6SL3710-1GH34-7AA3-Z	450	1800	1340
6SL3710-1GH35-8AA3-Z	560	1800	1340
6SL3710-1GH37-4AA3-Z	710	2200	2000
6SL3710-1GH38-1AA3-Z	800	2200	2040
6SL3710-2GH41-1AA3-Z	1000	3600	2660
6SL3710-2GH41-4AA3-Z	1350	4400	3980
6SL3710-2GH41-5AA3-Z	1500	4400	4060

SINAMICS G150

Drive converter cabinet units

75 kW to 2700 kW

Options (continued)

L07

dv/dt filter compact plus Voltage Peak Limiter

dv/dt filter plus VPL (Voltage Peak Limiter) limit the voltage rate-of-rise dv/dt to values < 1600 V/μs and the typical voltage peaks to the following values according to the limit value curve A to IEC 60034-25: 2007:

- < 1150 V at $V_{line} < 575$ V
- < 1400 V at 660 V < $V_{line} < 690$ V

The dv/dt filter compact plus VPL functionally consists of two components that are supplied as a compact mechanical unit, the dv/dt reactor and the voltage limiting network (VPL), which limits voltage peaks and feeds back the energy to the DC link. Its dimensions are so compact that it can be completely integrated in the cabinet – even for high power ratings. A supplementary cabinet is not required.

By using a dv/dt filter compact plus VPL, standard motors with a standard insulation and without insulated bearings with supply voltages of up to 690 V can be used for converter operation.

dv/dt filter compact plus VPL are designed for the following maximum motor cable lengths:

- Shielded cables 100 m (e.g. Protodur NYCWY)
- Unshielded cables 150 m (e.g. Protodur NYY)

For longer cable lengths (> 100 m shielded, > 150 m unshielded), the dv/dt filter plus VPL (option **L10**) should be used.

Notice:

- The max. permissible cable length between the dv/dt filter and Power Module is 5 m.
- Operation with output frequencies < 10 Hz is permissible for max. 5 min.
- Please observe the corresponding notes in the SINAMICS Low Voltage Engineering Manual (as PDF on the CD-ROM included with the catalog).

Note: Option **L07** cannot be combined with the following options:

- **L08** (motor reactor)
- **L10** (dv/dt filter plus VPL)
- **L15** (sine-wave filter)
- **M78** (top cable entry, motor side)

L08

Motor reactor

Motor reactors reduce the voltage load on the motor windings by reducing the voltage gradients on the motor terminals generated when the converter is used. At the same time, the capacitive charge/discharge currents that place an additional load on the converter output when long motor cables are used are reduced. The maximum permissible output frequency when a motor reactor is used is 150 Hz.

Max. connectable motor cable lengths:

- Shielded cables 300 m (e.g. Protodur NYCWY)
- Unshielded cables 450 m (e.g. Protodur NYY)

Note: Option **L08** is only available for version A and cannot be combined with the following options:

- **L07** (dv/dt filter compact plus VPL)
- **L10** (dv/dt filter plus VPL)
- **L15** (sine-wave filter)
- **M78** (top cable entry, motor side)

L10

dv/dt filter plus Voltage Peak Limiter

dv/dt filter plus VPL (Voltage Peak Limiter) limit the voltage rate-of-rise dv/dt to values < 500 V/μs and the typical voltage peaks to the following values according to the limit value curve to IEC/TS 60034-17: 2006:

- < 1000 V at $V_{line} < 575$ V
- < 1250 V at 660 V < $V_{line} < 690$ V

The dv/dt filter plus VPL functionally consists of two components, the dv/dt reactor and the voltage limiting network (VPL), which limits voltage peaks and feeds the energy back to the DC link.

Depending on the converter output rating, option **L10** can be accommodated in the drive converter cabinet unit or an additional cabinet of width 400 mm is required.

Voltage range	Installation of the dv/dt filter plus VPL within the drive converter cabinet unit	Installation of the dv/dt filter plus VPL in a converter cabinet unit
V	kW	kW
380 ... 480	110 ... 250	315 ... 560
500 ... 600	110 ... 200	250 ... 560
660 ... 690	75 ... 315	400 ... 800

The dv/dt filter plus VPL is available on request for drive converter cabinet units with power units connected in parallel up to and including 1500 kW.

By using a dv/dt filter plus VPL, standard motors with a standard insulation and without insulated bearings with supply voltages of up to 690 V can be used for converter operation.

dv/dt filter plus VPL are designed for the following maximum motor cable lengths:

- Shielded cables 300 m (e.g. Protodur NYCWY)
- Unshielded cables 450 m (e.g. Protodur NYY)

For cable lengths < 100 m shielded or < 150 m unshielded, the dv/dt filter compact plus VPL (Option **L07**) can be advantageously used.

Please observe the corresponding notes in the SINAMICS Low Voltage Engineering Manual (as PDF on the CD-ROM included with the catalog).

Note: Option **L10** is not available for converters > 1500 kW with power units connected in parallel and cannot be combined with the following options:

- **L07** (dv/dt filter compact plus VPL)
- **L08** (motor reactor)
- **L15** (sine-wave filter)
- **M78** (top cable entry, motor side)

Options (continued)

L13
Line contactor (for currents ≤ 800 A for single circuit)

SINAMICS G150 drive converter cabinet units in a single circuit do not have a line contactor as standard. Option **L13** is needed if a switching element is required for disconnecting the cabinet from the supply (required for EMERGENCY OFF). The contactor is controlled and powered inside the converter. For units with rated input currents > 800 A in a single circuit, the function of option **L13** is provided by option **L26**.

Note: For converters with power units connected in parallel, the line contactor is included as standard.

Terminal -X50:	Meaning
4	Checkback contact (NO contact) Contactor closed
5	Checkback contact (NC contact) Contactor closed
6	Common root

L15
Sine-wave filter

Sine-wave filters are available in the voltage range 380 V to 480 V up to a type rating of 250 kW and in the voltage range 500 V to 600 V, up to a type rating of 132 kW.

The sine-wave filter at the converter output delivers practically sinusoidal voltages to the motor so that standard motors can be used without special insulation and without insulated bearings. Further, the sine-wave filter reduces the converter-related supplementary motor noise. The maximum permitted motor feeder cable length is limited to 300 m.

Note: The pulse frequency of the converter must be increased when used in conjunction with the **L15** option. This reduces the power available at the drive converter output (for the derating factor, refer to the SINAMICS Low Voltage Engineering Manual). The modulation depth of the output voltage decreases to approx. 85 % (380 V to 480 V) or approx. 83 % (500 V to 600 V). The maximum output frequency is 150 Hz. It should be noted that the reduced voltage at the motor terminals compared to the rated motor voltage means that the motor switches to field weakening mode earlier.

L19
Connection for external auxiliary equipment

An outgoing, controlled circuit fused with max. 10 A for external auxiliary equipment (for example, separately driven motor fan).

The voltage is tapped at the drive converter input upstream of the line contactor/circuit breaker and, therefore, has the same level as the supply voltage.

The outgoing circuit can be controlled internally by the converter or externally.

Terminal -X155:	Meaning	Range
1	L1	380 ... 690 V AC
2	L2	380 ... 690 V AC
3	L3	380 ... 690 V AC
11	Contactor control	230 V AC
12	Contactor control	230 V AC
13	Circuit breaker feedback signal	230 V AC / 0.5 A; 24 V DC / 2 A
14	Circuit breaker feedback signal	230 V AC / 0.5 A; 24 V DC / 2 A
15	Contactor feedback signal	230 V AC / 6 A
16	Contactor feedback signal	230 V AC / 6 A
PE	PE	

L22
Delivery scope without line reactor (for converters ≤ 500 kW)
L23
Line reactor $v_k = 2\%$ (for converters > 500 kW)

The line reactor is included as standard in the converter for converters up to 500 kW. For converter power ratings > 500 kW, including the parallel circuits, the line reactor ($v_k = 2\%$) is optionally available, as in this power range, the converter is often connected to the medium-voltage line supply via transformers that are adapted to the converter rating.

A line reactor is needed for high short-circuit power levels, partly to protect the actual converter against excessive harmonic currents, and thus against overload, and partly to limit line harmonics to the permitted values. The harmonic currents are limited by the complete inductance comprising the line reactor and mains supply cable inductance. Line reactors can be omitted if the line supply cable inductance is increased sufficiently, i.e. the value of RSC must be sufficiently small.

RSC = Relative Short-Circuit power: Ratio of short-circuit power $S_{k\text{Line}}$ at the supply connection point to the fundamental apparent output S_{conv} of the connected converters (to EN 50178/VDE 0160).

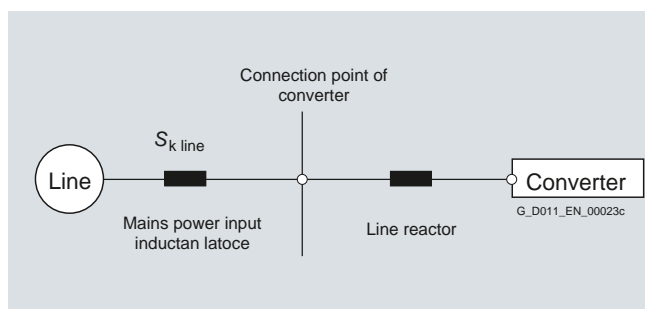

For SINAMICS G150 drive converter cabinet units the following applies:

Type rating kW	Line reactor can be omitted		Line reactor required	
	for RSC	Order code (option)	for RSC	Order code (option)
< 200	≤ 43	L22	> 43	-
200 ... 500	≤ 33	L22	> 33	-
≥ 500	≤ 20	-	> 20	L23

It is recommended that a line reactor is always connected on the line side of the converter, as in practice, it is often not known on which supply configuration individual converters are to be operated, i.e. which supply short-circuit power is present at the converter connection point.

The line reactor can only be omitted (option **L22**) if the values for RSC are lower than those shown in the table. This is the case, as shown in the following diagram, when the converter is connected to the line supply through a transformer with the appropriate rating.

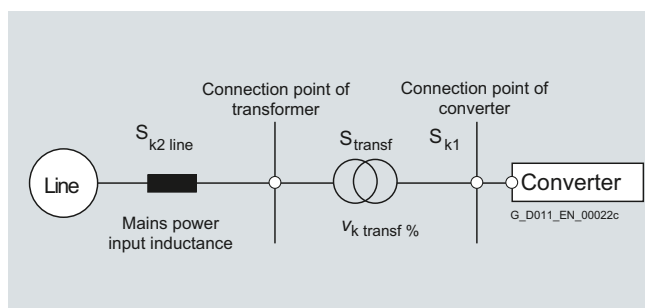

SINAMICS G150

Drive converter cabinet units

75 kW to 2700 kW

Options (continued)

As high-rating converters are usually connected to medium-voltage supply systems via transformers to reduce their harmonic effects on the supply, cabinet units over 500 kW are not equipped with line reactors as standard.

A line reactor (option **L23**) is always required, however, if

- for cabinet units > 500 kW, the RSC ratio is > 20, or
- several converters are connected to the same line connection point
- for cabinet units in a parallel circuit, the line supply is not fed-in through a three-winding transformer, or
- a line filter is used.

The SINAMICS Low Voltage Engineering Manual contains additional information on this topic (as PDF file on the CD-ROM included with the catalog).

Note: When option **L01** is selected, then a line reactor is not required (options **L22/L23** and **L01** cannot be combined).

L26

Main switch incl. fuses or circuit breakers

A switch disconnecter with fuses is available as the main switch for converters in a single circuit with ratings up to 800 A. Cabinets with an output current greater than 800 A are equipped with a circuit-breaker instead of a load disconnecter. The circuit breaker is controlled and supplied within the converter.

Option **L26** is included as standard for converters with parallel-connected power units and a rated input current of ≥ 1500 A. Circuit breakers are fitted in these units. For rated input currents < 1500 A, by selecting option **L26**, converters connected in parallel can be equipped with main switches including fuses in addition to the line contactor provided as standard.

L45

EMERGENCY OFF pushbutton, door mounted

The EMERGENCY OFF pushbutton with protective collar is installed in the converter cabinet door and its contacts are connected to the terminal block. The EMERGENCY OFF functions, Category 0 or 1, can be activated in conjunction with options **L57**, **L59** and **L60**.

Notice: By pressing the EMERGENCY OFF pushbutton, in compliance with IEC 60204-1 (VDE 0113), the motor is stopped – either uncontrolled or controlled depending on the selected Category 0 or 1 – and the converter isolated from the line supply. Auxiliary voltages, e.g. for a separately driven fan supply or anti-condensation heating, may still be present. Certain areas within the converter also remain live, e.g. the control or auxiliaries. If complete disconnection of all voltages is required, the EMERGENCY OFF pushbutton must be incorporated into a protective system to be implemented by the customer. For this purpose, an NC contact is provided at terminal –X120.

The EMERGENCY OFF pushbutton is preconfigured at the factory only when one of the options **L57** to **L60** is selected simultaneously. Other circuit arrangements must be implemented on the plant side.

L50

Cabinet light with service socket

One handheld lamp and a service socket is installed for each cabinet element.

The power supply (at terminal block -X390) for the cabinet light and the socket must be provided externally and fused with max. 10 A. The cabinet light is switched on manually using a switch.

Terminal	Meaning
-X390:	
1	L1 (230 V AC)
2	N
3	PE

L55

Cabinet anti-condensation heating

The cabinet anti-condensation heating is recommended at low ambient temperatures and high levels of humidity to prevent condensation. A 100 W electrical cabinet heater is installed for each cabinet element (two heating units are installed for each element for cabinet element widths from 800 mm to 1200 mm).

The power supply for the cabinet anti-condensation heating (110 V to 230 V AC, at terminal block -X240) must be provided externally and fused with max. 16 A.

Terminal	Meaning
-X240:	
1	L1 (110 ... 230 V AC)
2	N
3	PE

L57

EMERGENCY OFF Category 0, 230 V AC or 24 V DC

EMERGENCY OFF Category 0 for uncontrolled stopping in accordance with EN 60204-1.

The function includes interrupting the power feed for the converter via the line contactor and bypassing the microprocessor controller using a safety combination according to EN 60204-1. The motor then coasts down. When shipped, the pushbutton circuit is preset to 230 V AC. Jumpers must be appropriately set when using 24 V DC.

Notice: Option **L57** always requires electrical separation from the line supply, i.e. for converters in a single circuit for converter currents ≤ 800 A, option **L13** and for converter currents > 800 A, option **L26**. For converters with power units connected in parallel, electrical separation from the line supply is included as standard.

Terminal	Meaning
-X120:	
7	Looping in EMERGENCY OFF pushbutton from the customer side (plant side); remove jumper 7-8!
8	Looping in EMERGENCY OFF pushbutton from the customer side (plant side); remove jumper 7-8!
15	"On" for monitored start; remove jumper 15-16!
16	"On" for monitored start; remove jumper 15-16!
17	Feedback signal "safety combination tripped"
18	Feedback signal "safety combination tripped"

Options (continued)

L59 EMERGENCY STOP Category 1, 230 V AC

EMERGENCY STOP Category 1 for controlled stopping in accordance with EN 60204-1.

The function includes shutting down the drive via a fast stop along a deceleration ramp to be parameterized by the user. The power feed to the converter is then interrupted as described for EMERGENCY OFF Category 0.

A braking unit may be necessary to achieve the required shut-down times.

Notice: Option **L59** always requires electrical separation from the line supply, i.e. for converters in a single circuit for converter currents ≤ 800 A, option **L13** and for converter currents > 800 A, option **L26**. For converters with power units connected in parallel, electrical separation from the line supply is included as standard.

Terminal -X120:	Meaning
7	Looping in EMERGENCY OFF pushbutton from the customer side (plant side); remove jumper 7-8!
8	Looping in EMERGENCY OFF pushbutton from the customer side (plant side); remove jumper 7-8!
15	"On" for manual start; remove jumper 15-16!
16	"On" for manual start; remove jumper 15-16!
17	Feedback signal "safety combination tripped"
18	Feedback signal "safety combination tripped"

L60 EMERGENCY STOP Category 1, 24 V DC

EMERGENCY STOP Category 1 for controlled stopping in accordance with EN 60204-1.

The function includes shutting down the drive via a fast stop along a deceleration ramp to be parameterized by the user. The power feed to the converter is then interrupted as described for EMERGENCY OFF Category 0.

A braking unit may be necessary to achieve the required shut-down times.

Notice: Option **L60** always requires electrical separation from the line supply, i.e. for converters in a single circuit for converter currents ≤ 800 A, option **L13** and for converter currents > 800 A, option **L26**. For converters with power units connected in parallel, electrical separation from the line supply is included as standard.

Terminal -X120:	Meaning
7	Looping in EMERGENCY OFF pushbutton from the customer side (plant side); remove jumper 7-8!
8	Looping in EMERGENCY OFF pushbutton from the customer side (plant side); remove jumper 7-8!
15	"On" for manual start; remove jumper 15-16!
16	"On" for manual start; remove jumper 15-16!
17	Feedback signal "safety combination tripped"
18	Feedback signal "safety combination tripped"

L61, L62 Braking units

It may be necessary to use braking units for drives that can operate in generator mode.

The braking unit comprises two components:

- A Braking Module that is installed in the converter cabinet, and
- A braking resistor to be installed externally (IP20 degree of protection).

The braking unit functions as an autonomous unit, and does not require an external power supply. The braking energy is converted into heat in the braking resistor that must be mounted externally.

A maximum cable length of 100 m is permissible between the Braking Module and the braking resistor. This allows the braking resistor to be mounted externally so that heat losses can be dissipated outside the converter enclosure.

The braking resistor is connected to terminal block -X5 on the drive converter cabinet unit:

Terminal -X5:	Meaning
1	Braking resistor connection
2	Braking resistor connection

Characteristic curves

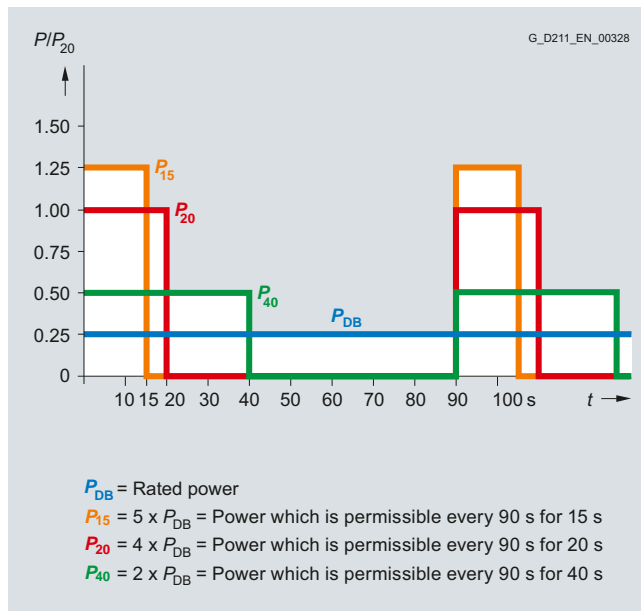

Load diagram for Braking Modules and braking resistors

Information on possible load cycles of the braking units as well as additional project guidelines are provided in the SINAMICS Low Voltage Engineering Manual, which is available as PDF on the CD-ROM included with Catalog D 11.

SINAMICS G150

Drive converter cabinet units

75 kW to 2700 kW

Options (continued)

The following braking units are available for the SINAMICS G150 converters and must be selected according to the converter rating:

Option	SINAMICS G150 converter cabinet units Type rating kW	Braking Module				Braking resistance R_B Ohm
		P_{DB} kW	P_{40} kW	P_{20} kW	P_{15} kW	
380 ... 480 V 3 AC						
L61	110 ... 132	25	50	100	125	4.4 ±7.5 %
L62	160 ... 900	50	100	200	250	2.2 ±7.5 %
500 ... 600 V 3 AC						
L62	110 ... 1000	50	100	200	250	3.4 ±7.5 %
660 ... 690 V 3 AC						
L61	75 ... 132	25	50	100	125	9.8 ±7.5 %
L62	160 ... 2700	50	100	200	250	4.9 ±7.5 %

P_{DB} : Rated power (continuous braking power)

P_{40} : 40 s power referred to a braking interval of 90 s

P_{20} : 20 s power referred to a braking interval of 90 s

P_{15} : 15 s power referred to a braking interval of 90 s

A second 50 kW braking unit can be installed in converters with parallel-connected power units in order to increase the braking power. In this case, one Braking Module is assigned to each braking resistor. You can order a second braking unit by selecting option **L62** twice.

If more braking power is required than provided by the braking units listed here, then braking units may be connected in parallel for higher converter outputs (on request).

Notes on this topic are also provided in the SINAMICS Low Voltage Engineering Manual.

L83

Thermistor motor protection unit (alarm)

Thermistor motor protection unit for PTC temperature thermistors (PTC resistors, type A) for alarm. The thermistor motor protection unit is supplied with power and evaluated internally in the converter.

Terminal	Meaning
-F127:	
T1	Sensor loop connection
T2	Sensor loop connection

L84

Thermistor motor protection unit (shutdown)

Thermistor motor protection unit for PTC temperature thermistors (PTC resistors, type A) for shutdown (tripping). The thermistor motor protection unit is supplied with power and evaluated internally in the converter.

Terminal	Meaning
-F125:	
T1	Sensor loop connection
T2	Sensor loop connection

L86

PT100 evaluation unit

The PT100 evaluation unit can monitor up to 6 sensors. The sensors can be connected in a two or three-wire system. The limit values can be freely programmed for each channel.

In the factory setting, the measurement channels are divided into two groups of 3 channels. For motors, for example, this means that three PT100s in the stator windings and two PT100s in the motor bearings can be monitored. Unused channels can be suppressed by parameter settings.

The output relays are integrated into the internal fault and shutdown sequence of the converter.

L87

Insulation monitoring

An insulation monitor must be used if the converter is operated on an ungrounded system. The device monitors the entire galvanically coupled circuit for insulation faults.

An alarm is output in the event of a fault.

Notice: Only **one** insulation monitor can be used in each electrically coupled line supply.

As there are different response strategies when a ground fault occurs in an ungrounded system, output relays of the insulation monitor are provided for integration in a plant-side control. There is also the possibility of integrating the outputs in the plant in the converter monitoring.

Terminal	Meaning
-A1-A101:	
11	Signaling relay ALARM 1
12	Signaling relay ALARM 1
14	Signaling relay ALARM 1
21	Signaling relay ALARM 2
22	Signaling relay ALARM 2
24	Signaling relay ALARM 2
M+	External kΩ display 0 μA to 400 μA
M-	External kΩ display 0 μA to 400 μA
R1	External reset button (NC contact or wire jumper, otherwise the error message is not stored)
R2	External reset button (NC contact or wire jumper)
T1	External test button
T2	External test button

Insulation monitoring can be supplied on request for drive converter cabinet units with power units connected in parallel.

M06

Base 100 mm high, RAL 7022

The additional cabinet base allows larger bending radii for cables (cable inlet from below) and enables them to be routed within the cabinet base.

The cabinet base is supplied in RAL 7022 in all cases. A special paint finish is not available for the base. It is delivered completely assembled with the cabinet. The mounting height of the operator panel changes accordingly.

Options (continued)

M07

Cable plinth 200 mm high, RAL 7035

The cable wiring compartment is made of strong sheet steel and allows cables to be connected more flexibly (entry from below). It also allows routing of cables within the cable wiring compartment. It is delivered completely assembled with the cabinet. The mounting height of the operator panel changes accordingly.

Notice: The cable wiring compartment is painted as standard with RAL 7035. If a special color is requested for the cabinet (order code **Y09**), the cable wiring compartment is also painted in this color.

M13

Top cable entry, line side

The control cabinet is provided with an additional hood to allow a top cable entry, line side. The connecting lugs for the power cables, the clamping bar for mechanically securing the cables, an EMC shield busbar, and a PE busbar are located inside the hood.

The cabinet height is therefore increased by 405 mm. The busbars for connection from above are fully mounted and installed when the cabinet is delivered. For transport reasons, the hoods are delivered separately and must be fitted by the customer. Crane transport assemblies (option **M90**) can still be used.

However, they must be removed on site before the hoods can be installed. The use of rope spreaders must be taken into consideration in the case of low crane hook heights.

An undrilled aluminum mounting plate (5 mm thick) is provided in the roof section for feeding in the cables. Depending on the number of cables and the cross-sections used, holes for attaching cable glands for feeding in the cables must be drilled in this mounting plate on-site.

Note: The control cables are still connected from below. When option **M13** is selected, the standard line connection from below is not provided.

The degree of protection of the hoods is IP21. When combined with options **M23**, **M43** and **M54**, additional plastic ventilation grilles and filter elements are provided.

Notice: The hoods have a RAL 7035 color as standard. If a special color is requested for the cabinet (order code **Y09**), the hoods are also painted in this color. Ventilation grilles provided for IP23, IP43 and IP54 degrees of protection have a RAL 7035 color and cannot be painted.

Option **M13** cannot be combined with option **L50** (cabinet light with service socket) for drive converter cabinet units with power units connected in parallel.

M21

Degree of protection IP21

Cabinet version in IP20, but with additional top cover or canopy. This increases the cabinet height by 250 mm.

For transport reasons, the top covers or canopies are delivered separately and must be fitted on site.

Notice: The top covers or canopies are painted in RAL 7035 as standard. If a special color is requested for the cabinet (order code **Y09**), the top covers or canopies will also be painted this color.

M23/M43/M54

Degree of protection IP23/IP43/IP54

When selecting **M23**, **M43** or **M54** then the converter is equipped with a hood. This increases the cabinet height by 400 mm.

For transport reasons, the hoods are delivered separately and must be fitted by the customer.

Notice: The hoods have a RAL 7035 color as standard. If a special color is requested for the cabinet (order code **Y09**), the hoods are also painted in this color. The molded plastic parts (e.g. ventilation grilles) have a RAL 7035 color and cannot be painted.

M66

Marine version

For compliance with the requirements of the classification institutes:

- Lloyds Register
- American Bureau of Shipping
- Germanischer Lloyd
- Bureau Veritas
- Det Norske Veritas
- Chinese Classification Society

This option includes a strengthened mechanical version of the cabinet, handles (handrail) below the operator panel and mechanical locking of the cabinet doors. The cabinet has degree of protection IP23 (**M23** option) and includes a cabinet anti-condensation heater (**L55** option). To attach the drive converter to a ship's deck, a welding frame (5 mm high) is supplied separately.

Option **M66** is not available for converters > 1500 kW with power units connected in parallel.

Note: Options **M21**, **M23** and **L01** or **L55** cannot be combined. If the converter is used for a safety-relevant drive on a ship, then individual certification is also required (see options **E11** to **E71**) – these include option **M66**.

M70

EMC shield busbar (cable connection from below)

The EMC shield busbar is used to connect shielded power cables for line supply and motor feeder lines. The EMC shield busbar is included as standard with option **L00** (RFI suppression filter).

SINAMICS G150

Drive converter cabinet units

75 kW to 2700 kW

Options (continued)

M78

Top cable entry, motor side

The control cabinet is provided with an additional hood for a top cable entry, motor side. The connecting lugs for the power cables, the clamping bar for mechanically securing the cables, an EMC shield busbar, and a PE busbar are located inside the hood.

The cabinet height is therefore increased by 405 mm. The busbars for connection from above are fully mounted and installed when the cabinet is delivered. For transport reasons, the hoods are delivered separately and must be fitted by the customer. Crane transport assemblies (option **M90**) can still be used. However, they must be removed on site before the hoods can be installed.

An undrilled aluminum mounting plate (5 mm thick) is provided in the roof section for feeding in the cables. Depending on the number of cables and the cross-sections used, holes for attaching cable glands for feeding in the cables must be drilled in this mounting plate on-site.

Note: The control cables are still connected from below. When option **M78** is selected, the standard motor connection from below is not provided. A combination with motor-side options **L07**, **L08**, **L10** and **L15** is not possible. If option **M78** and option **L61** or **L62** are simultaneously selected, then the braking resistor should also be connected from above.

The degree of protection of the hoods is IP21. When combined with options **M23**, **M43** and **M54**, additional plastic ventilation grilles and filter elements are provided.

Notice: The hoods have a RAL 7035 color as standard. If a special color is requested for the cabinet (order code **Y09**), the hoods are also painted in this color. Ventilation grilles provided for IP23, IP43 and IP54 degrees of protection have a RAL 7035 color and cannot be painted.

M90

Crane transport assembly (top-mounted)

In the case of single cabinets up to a width of 600 mm, transport eyebolts are provided to transport the unit by crane. For cabinet widths of 800 mm and wider, transport rails are used.

Rope spreaders should be used for low crane hook heights.

T58, T60, T80

Rating plate data

As standard, the rating plate is in English/German.

A rating plate in another language can be selected by specifying the following option order codes.

Order code	Rating plate language
T58	English/French
T60	English/Spanish
T80	English/Italian

Y09

Special cabinet paint finish

The converter cabinet units are painted with RAL 7035 as standard. The special paint finish must be stated in plain text in the order. All RAL colors which are available as powder coatings can be selected.

Notice: If options such as cable plinth (order code **M07**), top covers or canopies (order code **M21**), hoods (order codes **M23/M43/M54**) or cable connection from above (order codes **M13/M78**) are ordered for the drive converter cabinet units, they will also be supplied in the special paint finish. The molded plastic parts (e.g. ventilation grilles) have a RAL 7035 color and cannot be painted.

SINAMICS G150

Drive converter cabinet units

Line-side power components
Recommended fuses

Overview

The fuses specified below are the recommended types for protecting the unit on the low-voltage distribution panel. If option **L26** (main switch or circuit breaker) has been selected, the converter has integrated semiconductor protection. In this case, a fuse of type 3NA can be used on the low-voltage distribution panel.

If option **L26** has not been selected, we strongly advise that 3NE fuses are used ¹⁾.

Additional information on the fuses is provided in Catalog LV 10.1

Single circuit

Type rating		SINAMICS G150 converter	Fuse when fuse switch disconnecter (option L26) is installed	Rated current	Frame size acc. to IEC 60269-2	Fuse (incl. semiconductor protection) without fuse switch disconnecter	Rated current	Frame size acc. to IEC 60269-2
(at 400 V, 500 V or 690 V)	(at 60 Hz, 460 V or 575 V)		Type	A		Type	A	
kW	hp							
380 ... 480 V 3 AC								
110	150	6SL3710-1GE32-1 . A3	3NA3144	250	2	3NE1230-2	315	1
132	200	6SL3710-1GE32-6 . A3	3NA3250	300	2	3NE1331-2	350	2
160	250	6SL3710-1GE33-1 . A3	3NA3254	355	3	3NE1334-2	500	2
200	300	6SL3710-1GE33-8 . A3	3NA3260	400	3	3NE1334-2	500	2
250	400	6SL3710-1GE35-0 . A3	3NA3372	630	3	3NE1436-2	630	3
315	500	6SL3710-1GE36-1 . A3	3NA3475	800	4	3NE1438-2	800	3
400	600	6SL3710-1GE37-5 . A3	3NA3475	800	4	3NE1448-2	850	3
450	600	6SL3710-1GE38-4 . A3	3NA3365	2 x 500	3	3NE1436-2	2 x 630	3
560	800	6SL3710-1GE41-0 . A3	3NA3472	2 x 630	3	3NE1437-2	2 x 710	3
500 ... 600 V 3 AC								
110	150	6SL3710-1GF31-8 . A3	3NA3244-6	250	2	3NE1227-2	250	1
132	200	6SL3710-1GF32-2 . A3	3NA3252-6	315	2	3NE1230-2	315	1
160	250	6SL3710-1GF32-6 . A3	3NA3354-6	355	3	3NE1331-2	350	2
200	300	6SL3710-1GF33-3 . A3	3NA3365-6	500	3	3NE1334-2	500	2
250	400	6SL3710-1GF34-1 . A3	3NA3365-6	500	3	3NE1334-2	500	2
315	450	6SL3710-1GF34-7 . A3	3NA3352-6	2 x 315	3	3NE1435-2	560	3
400	500	6SL3710-1GF35-8 . A3	3NA3354-6	2 x 355	3	3NE1447-2	670	3
500	700	6SL3710-1GF37-4 . A3	3NA3365-6	2 x 500	3	3NE1448-2	850	3
560	800	6SL3710-1GF38-1 . A3	3NA3365-6	2 x 500	3	3NE1334-2	2 x 500	2
660 ... 690 V 3 AC								
75		6SL3710-1GH28-5 . A3	3NA3132-6	125	1	3NE1022-2	125	00
90		6SL3710-1GH31-0 . A3	3NA3132-6	125	1	3NE1022-2	125	00
110		6SL3710-1GH31-2 . A3	3NA3136-6	160	1	3NE1224-2	160	1
132		6SL3710-1GH31-5 . A3	3NA3240-6	200	2	3NE1225-2	200	1
160		6SL3710-1GH31-8 . A3	3NA3244-6	250	2	3NE1227-2	250	1
200		6SL3710-1GH32-2 . A3	3NA3252-6	315	2	3NE1230-2	315	1
250		6SL3710-1GH32-6 . A3	3NA3354-6	355	3	3NE1331-2	350	2
315		6SL3710-1GH33-3 . A3	3NA3365-6	500	3	3NE1334-2	500	2
400		6SL3710-1GH34-1 . A3	3NA3365-6	500	3	3NE1334-2	500	2
450		6SL3710-1GH34-7 . A3	3NA3352-6	2 x 315	3	3NE1435-2	560	3
560		6SL3710-1GH35-8 . A3	3NA3354-6	2 x 355	3	3NE1447-2	670	3
710		6SL3710-1GH37-4 . A3	3NA3365-6	2 x 500	3	3NE1448-2	850	3
800		6SL3710-1GH38-1 . A3	3NA3365-6	2 x 500	3	3NE1334-2	2 x 500	2

Note: The power data in hp units are based on the NEC/CEC standards for the North American market.

¹⁾ The combined fuses (3NE1.), gS operating class for cable and semiconductor protection are recommended to protect the converter. These fuses are specially adapted to the requirements of the semiconductors in the input rectifier.

- Superfast
- Adapted to the limit current integral of the semiconductor
- Low arc voltage
- improved current limiting.

SINAMICS G150

Drive converter cabinet units

Line-side power components Recommended fuses

Overview (continued)

Parallel circuit (data per converter subsystem)

Type rating		SINAMICS G150 converter	Fuse when fuse switch disconnecter (option L26) is installed			Fuse (incl. semiconductor protection) without fuse switch disconnecter		
(at 400 V, 500 V or 690 V)	(at 60 Hz, 460 V or 575 V)		Rated current	Frame size acc. to IEC 60269-2	Rated current	Frame size acc. to IEC 60269-2	Type	A
kW	hp	Type	A	Type	A	Type	A	Type
380 ... 480 V 3 AC								
630	900	6SL3710-2GE41-1AA3	3NA3475	800	4	3NE1438-2	800	3
710	1200	6SL3710-2GE41-4AA3	3NA3475	800	4	3NE1448-2	850	3
900	1200	6SL3710-2GE41-6AA3	3NA3365	2 x 500	3	3NE1436-2	2 x 630	3
500 ... 600 V 3 AC								
630	900	6SL3710-2GF38-6AA3	3NA3352-6	2 x 315	3	3NE1435-2	560	3
710	1000	6SL3710-2GF41-1AA3	3NA3365-6	2 x 500	3	3NE1447-2	670	3
1000	1600	6SL3710-2GF41-4AA3	3NA3365-6	2 x 500	3	3NE1448-2	850	3
660 ... 690 V 3 AC								
1000		6SL3710-2GH41-1AA3	3NA3354-6	2 x 355	3	3NE1447-2	670	3
1350		6SL3710-2GH41-4AA3	3NA3365-6	2 x 500	3	3NE1448-2	850	3
1500		6SL3710-2GH41-5AA3	3NA3365-6	2 x 500	3	3NE1334-2	2 x 500	2
1750		6SL3710-2GH41-8EA3	3NA3365-6	2 x 500	3	3NE1435-2	2 x 560	3
1950		6SL3710-2GH42-0EA3	3NA3362-6	3 x 425	3	3NE1436-3	2 x 630	3
2150		6SL3710-2GH42-2EA3	3NA3365-6	3 x 500	3	3NE1334-2	3 x 500	2
2400		6SL3710-2GH42-4EA3	3NA3365-6	3 x 500	3	3NE1334-2	3 x 500	2
2700		6SL3710-2GH42-7EA3	3NA3372	3 x 630	3	3NE1436-3	3 x 630	3

Note: The power data in hp units are based on the NEC/CEC standards for the North American market.

SINAMICS G150

Drive converter cabinet units

Conductor cross-sections and terminals

Overview

The following tables list the recommended and maximum possible cable connections at the line and motor ends for a single circuit connection (versions A and C) and a parallel circuit (version A).

The recommended cross-sections are based on the specified fuses. They are applicable for 3-wire cables manufactured out of copper with PVC insulation, routed horizontally in air and a permissible wire temperature of 70 °C (e.g. Protodur NYY or

NYCWY) for an ambient temperature of 40 °C and individual routing.

When the conditions differ from those specified above (cable routing, cable grouping, ambient temperature), the appropriate correction factors according to IEC 60364-5-52 must be taken into account.

The SINAMICS Low Voltage Engineering Manual contains additional information and is available as a PDF file on the CD-ROM included with Catalog D 11.

Single circuit

Type rating	Converter SINAMICS G150 Version A	Line connection			Motor connection			Cabinet grounding	
		Recom- mended cross- section ¹⁾	Maximum conductor cross- section	M12 fixing screw	Recom- mended cross- section ¹⁾	Maximum conductor cross- section	M12 fixing screw	M12 fixing screw	Comment
kW		IEC mm ²	IEC mm ²	(Number of holes)	IEC mm ²	IEC mm ²	(Number of holes)	(Number of holes)	
380 ... 480 V 3 AC									
110	6SL3710-1GE32-1AA3	2 x 70	4 x 240	(2)	2 x 50	2 x 150	(2)	(2)	
132	6SL3710-1GE32-6AA3	2 x 95	4 x 240	(2)	2 x 70	2 x 150	(2)	(2)	
160	6SL3710-1GE33-1AA3	2 x 120	4 x 240	(2)	2 x 95	2 x 150	(2)	(2)	
200	6SL3710-1GE33-8AA3	2 x 120	4 x 240	(2)	2 x 95	2 x 150	(2)	(2)	
250	6SL3710-1GE35-0AA3	2 x 185	4 x 240	(2)	2 x 150	2 x 240	(2)	(2)	
315	6SL3710-1GE36-1AA3	2 x 240	4 x 240	(2)	2 x 185	4 x 240	(2)	(2)	
400	6SL3710-1GE37-5AA3	3 x 185	4 x 240	(2)	2 x 240	4 x 240	(2)	(10)	Cu busbar
450	6SL3710-1GE38-4AA3	4 x 150	8 x 240	(4)	3 x 185	4 x 240	(2)	(16)	Cu busbar
560	6SL3710-1GE41-0AA3	4 x 185	8 x 240	(4)	4 x 185	6 x 240	(3)	(18)	Cu busbar
500 ... 600 V 3 AC									
110	6SL3710-1GF31-8AA3	120	4 x 240	(2)	95	2 x 150	(2)	(2)	
132	6SL3710-1GF32-2AA3	2 x 70	4 x 240	(2)	120	2 x 150	(2)	(2)	
160	6SL3710-1GF32-6AA3	2 x 95	4 x 240	(2)	2 x 70	2 x 185	(2)	(2)	
200	6SL3710-1GF33-3AA3	2 x 120	4 x 240	(2)	2 x 95	2 x 240	(2)	(2)	
250	6SL3710-1GF34-1AA3	2 x 185	4 x 240	(2)	2 x 120	4 x 240	(2)	(2)	
315	6SL3710-1GF34-7AA3	2 x 185	4 x 240	(2)	2 x 150	4 x 240	(2)	(2)	
400	6SL3710-1GF35-8AA3	2 x 240	4 x 240	(2)	2 x 185	4 x 240	(2)	(2)	
500	6SL3710-1GF37-4AA3	3 x 185	8 x 240	(4)	2 x 240	6 x 240	(3)	(18)	Cu busbar
560	6SL3710-1GF38-1AA3	4 x 150	8 x 240	(4)	3 x 185	6 x 240	(3)	(18)	Cu busbar
660 ... 690 V 3 AC									
75	6SL3710-1GH28-5AA3	50	4 x 240	(2)	35	2 x 70	(2)	(2)	
90	6SL3710-1GH31-0AA3	50	4 x 240	(2)	50	2 x 150	(2)	(2)	
110	6SL3710-1GH31-2AA3	70	4 x 240	(2)	70	2 x 150	(2)	(2)	
132	6SL3710-1GH31-5AA3	95	4 x 240	(2)	70	2 x 150	(2)	(2)	
160	6SL3710-1GH31-8AA3	120	4 x 240	(2)	95	2 x 150	(2)	(2)	
200	6SL3710-1GH32-2AA3	2 x 70	4 x 240	(2)	120	2 x 150	(2)	(2)	
250	6SL3710-1GH32-6AA3	2 x 95	4 x 240	(2)	2 x 70	2 x 185	(2)	(2)	
315	6SL3710-1GH33-3AA3	2 x 120	4 x 240	(2)	2 x 95	2 x 240	(2)	(2)	
400	6SL3710-1GH34-1AA3	2 x 185	4 x 240	(2)	2 x 120	4 x 240	(2)	(2)	
450	6SL3710-1GH34-7AA3	2 x 185	4 x 240	(2)	2 x 150	4 x 240	(2)	(2)	
560	6SL3710-1GH35-8AA3	2 x 240	4 x 240	(2)	2 x 185	4 x 240	(2)	(2)	
710	6SL3710-1GH37-4AA3	3 x 185	8 x 240	(4)	3 x 150	6 x 240	(3)	(18)	Cu busbar
800	6SL3710-1GH38-1AA3	4 x 150	8 x 240	(4)	3 x 185	6 x 240	(3)	(18)	Cu busbar

¹⁾ The recommendations for the North American market in AWG or MCM must be taken from the appropriate NEC (National Electrical Code) and/or CEC (Canadian Electrical Code) standards.

SINAMICS G150

Drive converter cabinet units

Conductor cross-sections and terminals

Overview (continued)

Single circuit

Type rating	Converter SINAMICS G150 Version C	Line connection			Motor connection			Cabinet grounding	
		Recom- mended cross- section ¹⁾	Maximum conductor cross- section	M12 fixing screw	Recom- mended cross- section ¹⁾	Maximum conductor cross- section	M12 fixing screw	M12 fixing screw	Comment
kW		IEC mm ²	IEC mm ²	(Number of holes)	IEC mm ²	IEC mm ²	(Number of holes)	(Number of holes)	
380 ... 480 V 3 AC									
110	6SL3710-1GE32-1CA3	2 x 70	2 x 240	(1)	2 x 50	2 x 150	(1)	(2)	
132	6SL3710-1GE32-6CA3	2 x 95	2 x 240	(1)	2 x 70	2 x 150	(1)	(2)	
160	6SL3710-1GE33-1CA3	2 x 120	2 x 240	(1)	2 x 95	2 x 150	(1)	(2)	
200	6SL3710-1GE33-8CA3	2 x 120	2 x 240	(1)	2 x 95	2 x 150	(1)	(2)	
250	6SL3710-1GE35-0CA3	2 x 185	2 x 240	(1)	2 x 150	2 x 240	(1)	(2)	
315	6SL3710-1GE36-1CA3	2 x 240	4 x 240	(2)	2 x 185	4 x 240	(2)	(2)	
400	6SL3710-1GE37-5CA3	3 x 185	4 x 240	(2)	2 x 240	4 x 240	(2)	(8)	Cu busbar
450	6SL3710-1GE38-4CA3	4 x 150	8 x 240	(4)	3 x 185	4 x 240	(2)	(8)	Cu busbar
560	6SL3710-1GE41-0CA3	4 x 185	8 x 240	(4)	4 x 185	6 x 240	(3)	(10)	Cu busbar
500 ... 600 V 3 AC									
110	6SL3710-1GF31-8CA3	120	2 x 240	(1)	95	2 x 150	(1)	(2)	
132	6SL3710-1GF32-2CA3	2 x 70	2 x 240	(1)	120	2 x 150	(1)	(2)	
160	6SL3710-1GF32-6CA3	2 x 95	2 x 240	(1)	2 x 70	2 x 185	(1)	(2)	
200	6SL3710-1GF33-3CA3	2 x 120	2 x 240	(1)	2 x 95	2 x 240	(1)	(2)	
250	6SL3710-1GF34-1CA3	2 x 185	4 x 240	(2)	2 x 120	4 x 240	(2)	(2)	
315	6SL3710-1GF34-7CA3	2 x 185	4 x 240	(2)	2 x 150	4 x 240	(2)	(2)	
400	6SL3710-1GF35-8CA3	2 x 240	4 x 240	(2)	2 x 185	4 x 240	(2)	(2)	
500	6SL3710-1GF37-4CA3	3 x 185	8 x 240	(4)	2 x 240	6 x 240	(3)	(18)	Cu busbar
560	6SL3710-1GF38-1CA3	4 x 150	8 x 240	(4)	3 x 185	6 x 240	(3)	(18)	Cu busbar
660 ... 690 V 3 AC									
75	6SL3710-1GH28-5CA3	50	2 x 240	(1)	35	2 x 70	(1)	(2)	
90	6SL3710-1GH31-0CA3	50	2 x 240	(1)	50	2 x 150	(1)	(2)	
110	6SL3710-1GH31-2CA3	70	2 x 240	(1)	70	2 x 150	(1)	(2)	
132	6SL3710-1GH31-5CA3	95	2 x 240	(1)	70	2 x 150	(1)	(2)	
160	6SL3710-1GH31-8CA3	120	2 x 240	(1)	95	2 x 150	(1)	(2)	
200	6SL3710-1GH32-2CA3	2 x 70	2 x 240	(1)	120	2 x 150	(1)	(2)	
250	6SL3710-1GH32-6CA3	2 x 95	2 x 240	(1)	2 x 70	2 x 185	(1)	(2)	
315	6SL3710-1GH33-3CA3	2 x 120	2 x 240	(1)	2 x 95	2 x 240	(1)	(2)	
400	6SL3710-1GH34-1CA3	2 x 185	4 x 240	(2)	2 x 120	4 x 240	(2)	(2)	
450	6SL3710-1GH34-7CA3	2 x 185	4 x 240	(2)	2 x 150	4 x 240	(2)	(2)	
560	6SL3710-1GH35-8CA3	2 x 240	4 x 240	(2)	2 x 185	4 x 240	(2)	(2)	
710	6SL3710-1GH37-4CA3	3 x 185	8 x 240	(4)	3 x 150	6 x 240	(3)	(18)	Cu busbar
800	6SL3710-1GH38-1CA3	4 x 150	8 x 240	(4)	3 x 185	6 x 240	(3)	(18)	Cu busbar

¹⁾ The recommendations for the North American market in AWG or MCM must be taken from the appropriate NEC (National Electrical Code) and/or CEC (Canadian Electrical Code) standards.

Overview (continued)

Parallel circuit

Type rating	Converter SINAMICS G150 Version A	Line connection			Motor connection			Cabinet grounding	
		Recom- mended cross- section ¹⁾	Maximum conductor cross- section	M12 fixing screw	Recom- mended cross- section ¹⁾	Maximum conductor cross- section	M12 fixing screw	M12 fixing screw	Comment
kW		IEC mm ²	IEC mm ²	(Number of holes)	IEC mm ²	IEC mm ²	(Number of holes)	(Number of holes)	
380 ... 480 V 3 AC									
630	6SL3710-2GE41-1AA3	2 x 240	4 x 240	(2)	2 x 185	4 x 240	(2)	(2)	
710	6SL3710-2GE41-4AA3	3 x 185	4 x 240	(2)	2 x 240	4 x 240	(2)	(10)	Cu busbar
900	6SL3710-2GE41-6AA3	4 x 150	8 x 240	(4)	2 x 240	4 x 240	(2)	(16)	Cu busbar
500 ... 600 V 3 AC									
630	6SL3710-2GF38-6AA3	2 x 185	4 x 240	(2)	2 x 150	4 x 240	(2)	(2)	
710	6SL3710-2GF41-1AA3	2 x 240	4 x 240	(2)	2 x 185	4 x 240	(2)	(2)	
1000	6SL3710-2GF41-4AA3	3 x 185	8 x 240	(4)	2 x 240	6 x 240	(3)	(18)	Cu busbar
660 ... 690 V 3 AC									
1000	6SL3710-2GH41-1AA3	2 x 240	4 x 240	(2)	2 x 185	4 x 240	(2)	(2)	
1350	6SL3710-2GH41-4AA3	3 x 185	8 x 240	(4)	3 x 150	6 x 240	(3)	(18)	Cu busbar
1500	6SL3710-2GH41-5AA3	4 x 150	8 x 240	(4)	3 x 185	6 x 240	(3)	(18)	Cu busbar
1750	6SL3710-2GH41-8EA3	2 x 4 x 150	2 x 8 x 240	(4)	2 x 3 x 185	2 x 6 x 240	(3)	(18)	Cu busbar
1950	6SL3710-2GH42-0EA3	2 x 4 x 150	2 x 8 x 240	(4)	2 x 3 x 185	2 x 6 x 240	(3)	(18)	Cu busbar
2150	6SL3710-2GH42-2EA3	2 x 4 x 150	2 x 8 x 240	(4)	2 x 3 x 185	2 x 6 x 240	(3)	(18)	Cu busbar
2400	6SL3710-2GH42-4EA3	2 x 4 x 150	2 x 8 x 240	(4)	2 x 3 x 185	2 x 6 x 240	(3)	(18)	Cu busbar
2700 ²⁾	6SL3710-2GH42-7EA3	2 x 4 x 150	2 x 8 x 240	(4)	3 x 3 x 185	3 x 6 x 240	(3)	(18)	Cu busbar

Note: The recommended and maximum conductor cross-sections refer to one of the two partial converters in the parallel circuit.

Minimum motor cable lengths for operation with power units connected in parallel

When using power units connected in parallel, the following motor cable lengths must be observed if a motor is connected with only one winding system and no motor-side reactors or filters are used:

Type rating	SINAMICS G150 drive converter cabinet unit, version A	Minimum cable length
kW		m
380 ... 480 V 3 AC		
630	6SL3710-2GE41 1AA3	13
710	6SL3710-2GE41 4AA3	10
900	6SL3710-2GE41 6AA3	9
500 ... 600 V 3 AC		
630	6SL3710-2GF38 6AA3	18
710	6SL3710-2GF41 1AA3	15
1000	6SL3710-2GF41 4AA3	13
660 ... 690 V 3 AC		
1000	6SL3710-2GH41 1AA3	20
1350	6SL3710-2GH41 4AA3	18
1500	6SL3710-2GH41 5AA3	15
1750	6SL3710-2GH41-8EA3	12
1950	6SL3710-2GH42-0EA3	10
2150	6SL3710-2GH42-2EA3	8
2400	6SL3710-2GH42-4EA3	8
2700	6SL3710-2GH42-7EA3	8

¹⁾ The recommendations for the North American market in AWG or MCM must be taken from the appropriate NEC (National Electrical Code) and/or CEC (Canadian Electrical Code) standards.

²⁾ The motor-side inverter comprises three Motor Modules connected in parallel.

SINAMICS G150

Drive converter cabinet units

Conductor cross-sections and terminals

Overview (continued)

Required cable cross-sections for line and motor connections

It is always advisable to use shielded cables between the converter and motor and, in the case of drives in the higher output power range, symmetrical 3-wire, three-phase cables, and to connect several cables of this type in parallel where necessary. There are basically two reasons for this recommendation:

This is the only way in which the high IP55 degree of protection can be achieved for the motor terminal box without problems because the cables enter the terminal box via glands and the number of possible glands is limited by the geometry of the terminal box. Therefore single cables are less suitable.

With symmetrical, 3-wire, three-phase cables, the summed ampere-turns over the cable outer diameter are equal to zero and they can be routed in conductive, metal cable ducts or racks without any significant currents (ground current or leakage current) being induced in these conductive, metal connections. The danger of induced leakage currents and thus of increased cable-shield losses increases with single-wire cables.

The required cable cross-section depends on the amperage which flows through the cable. The permissible current loading of cables is defined, for example, in IEC 60364-5-52. It depends on ambient conditions such as the temperature, but also on the routing method. An important factor to consider is whether cables are routed singly and are therefore relatively well ventilated, or whether groups of cables are routed together. In the latter instance, the cables are much less well ventilated and might therefore heat one another to a greater degree. For the relevant correction factors applicable to these boundary conditions, please refer to IEC 60364-5-52.

The table below provides a guide to the recommended cross-sections (based on IEC 60364-5-52) for PVC-insulated, 3-wire copper and aluminum cables, a permissible conductor temperature of 70°C (e.g. Protodur NYY or NYCWY) and an ambient temperature of 40°C.

Current carrying capacity according to IEC 60364-5-52 at 40 °C

Cross-section 3-wire cable mm ²	Copper cable		Aluminum cable	
	Single routing	Groups of cables routed in parallel ¹⁾	Single routing	Groups of cables routed in parallel ¹⁾
3 x 2.5	22	17	17	13
3 x 4.0	30	23	23	18
3 x 6.0	37	29	29	22
3 x 10	52	41	40	31
3 x 16	70	54	53	41
3 x 25	88	69	68	53
3 x 35	110	86	84	65
3 x 50	133	104	102	79
3 x 70	171	133	131	102
3 x 95	207	162	159	124
3 x 120	240	187	184	144
3 x 150	278	216	213	166
3 x 185	317	247	244	190
3 x 240	374	292	287	224

¹⁾ Maximum 9 cables routed horizontally in direct contact with one another on a cable rack

With higher amperages, cables must be connected in parallel.

Note:

The recommendations for the North American market in AWG or MCM must be taken from the appropriate NEC (National Electrical Code)/CEC (Canadian Electrical Code) standards.

Grounding and PE conductor cross-section

The PE conductor must be dimensioned to meet the following requirements:

- In the case of a ground fault, no impermissibly high contact voltages resulting from voltage drops on the PE conductor caused by the ground fault current may occur (< 50 V AC or < 120 V DC, IEC 61800-5-1, IEC 60 364, IEC 60 543).
- The PE conductor should not be excessively loaded by any ground fault current it carries.
- If it is possible for continuous currents to flow through the PE conductor when a fault occurs, the PE conductor cross-section must be dimensioned for this continuous current.
- The PE conductor cross-section should be selected according to EN 60 204-1, EN 60 439-1, IEC 60 364.

Cross-section of the phase conductor mm ²	Minimum cross-section of external PE conductor mm ²
Up to 16	Minimum phase conductor cross-section
16 ... 35	16
35 and above	Minimum half the phase conductor cross-section

Note:

The recommendations for the North American market in AWG or MCM must be taken from the appropriate NEC (National Electrical Code)/CEC (Canadian Electrical Code) standards.

- Switchgear and motors are usually grounded via separate local ground connections. When this grounding arrangement is used, the current caused by a ground fault flows through the parallel ground connections and is divided. Despite the use of the relatively small PE conductor cross-sections specified in the table above, no impermissible contact voltages can develop with this grounding system.

Based on experience with different grounding configurations, however, we recommend that the ground wire from the motor should be routed directly back to the converter. For EMC reasons and to prevent bearing currents, symmetrical 3-wire three-phase cables should be used where possible instead of 4-wire cables, especially on drives in the higher power range. The protective or PE conductor must be routed separately when 3-wire cables are used or must be arranged symmetrically in the motor cable. The symmetry of the PE conductor is achieved using a conductor surrounding all phase conductors or using a cable with a symmetrical arrangement of the three phase conductors and three ground conductors. The SINAMICS Low Voltage Engineering Manual contains more detailed information on this topic and is available as a PDF file on the CD-ROM included with Catalog D 11.

- Through their controllers, the converters limit the load current (motor and ground fault currents) to an rms value corresponding to the rated current. We therefore recommend the use of a PE conductor cross-section analogous to the phase conductor cross-section for grounding the converter cabinet.

Tools and configuration

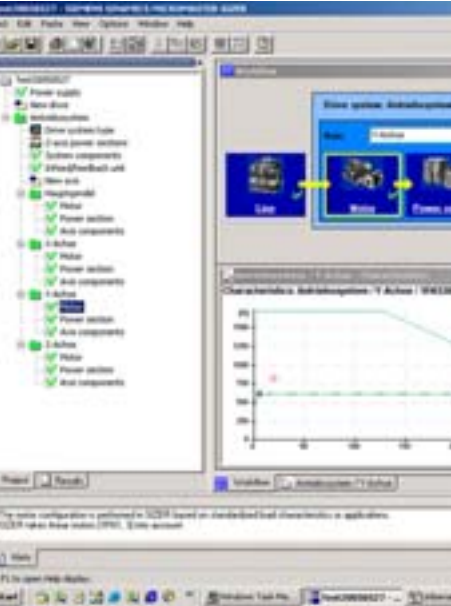

4/2

Engineering software

4/2

SIZER engineering tool

4/3

STARTER commissioning tool

4/6

Drive ES engineering system

4/8

Configuration

4/8

Engineering Manual

Tools and configuration Engineering software

SIZER engineering tool

Overview

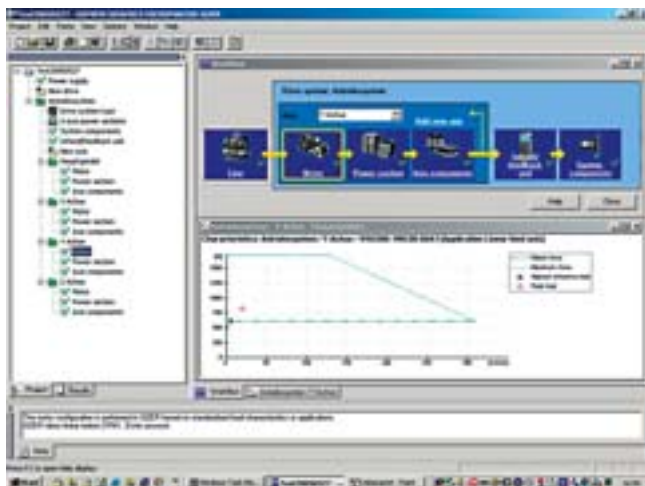

The following drives and controls can be engineered in a user-friendly fashion using the SIZER engineering tool:

- SINAMICS Low Voltage drive systems, MICROMASTER 4, DYNVERT T, SIMATIC ET 200S FC and SIMATIC ET 200pro FC
- Motor starters for network configuring
- SINUMERIK solution line CNC control
- SIMOTION motion control
- SIMATIC Technology

It provides support in the technical planning of the hardware and firmware components required to perform a specific drive task. SIZER covers the full range of operations required to configure a complete drive system, from simple single-motor drives to complex multi-axis applications.

SIZER supports all the engineering steps in a workflow:

- Configuring the line supply
- Designing the motor and gearbox, including calculation of mechanical transmission elements
- Configuring the drive components
- Identifying the required accessories
- Selecting the line-side and motor-side power options, e.g. cables, filters, and reactors

When SIZER was being designed, particular importance was placed on a high degree of usability and a holistic, function-based approach to the drive application. The extensive user guidance makes it easy to use the tool. Status information keeps the user continually informed about the progress of the configuration process.

The SIZER user interface is available in German, English, French and Italian.

The drive configuration is stored in a project. In the project, the components and functions used are displayed in a hierarchical tree structure.

The project view supports the configuration of drive systems and the copying/insertion/modification of drives already configured.

The configuration process produces the following results:

- A parts list of the required components (export to Excel, use of the Excel data sheet for import to VSR)
- Technical data of the system
- Characteristic curves
- Information about harmonic effects on the supply
- Design layout of drive and control components and dimension drawings of motors

These results are displayed in a results tree and can be reused for documentation purposes.

Technological online help is available:

- Detailed technical data
- Information about the drive systems and their components
- Decision-making criteria for the selection of components
- Online help in German, English, French, Italian, Chinese and Japanese

Minimum system requirements

PG or PC with Pentium III min. 800 MHz (recommended > 1 GHz) (Windows XP)

512 MB RAM (1024 MB RAM recommended)

At least 4.1 GB of free hard disk space

An additional 100 MB of free hard disk space on the Windows system drive

Screen resolution 1024 × 768 pixels

Windows XP Professional SP2 / XP Home Edition SP2 / Windows Vista Business

Microsoft Internet Explorer 5.5 SP2

Selection and ordering data

	Order No.
SIZER engineering tool For SINAMICS and MICROMASTER on DVD-ROM German, English, French, Italian	6SL3070-0AA00-0AG0

Further information

The SIZER engineering tool is available in the Internet at no charge under www.siemens.com/sizer

STARTER commissioning tool

Overview

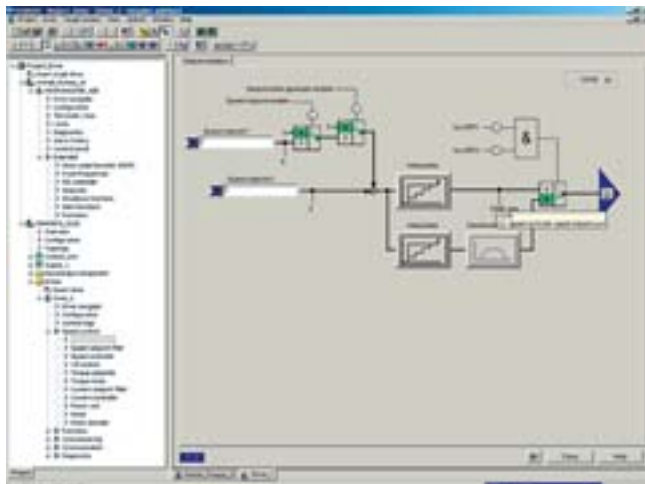

The user-friendly STARTER commissioning tool can be used for:

- Commissioning,
- Optimizing and
- Diagnostics

This software can be operated either as a standalone PC application, integrated in SIMATIC STEP 7 with TIA compatibility via Drive ES Basic, or also integrated in the SCOUT engineering system (for SIMOTION). The basic functions and handling is always the same.

In STARTER, MICROMASTER 4 units and the SIMATIC ET 200S FC and SIMATIC ET 200pro FC frequency converters are also supported in addition to SINAMICS drives.

The project wizard sets up the drives within the structure of the project tree.

Beginners are supported by solution-based dialog guidance, which offers a standardized graphics-based display to maximize clarity when setting the drive parameters.

First commissioning is guided by a wizard which makes all of the basic settings in the drive. Therefore, getting a motor up and running is merely a question of setting a few of the drive parameters as part of the drive configuration process.

The individual settings that may be required are made using graphics-based parameterization screens, which also precisely visualize the principle of operation of the drive.

Examples of individual settings that can be made include:

- How terminals are used
- Bus interface
- Setpoint channel (e.g. fixed setpoints)
- Closed-loop speed control (e.g. ramp-function generator, limits)
- BICO interconnections
- Diagnostics

For experts, the expert list can be used to specifically and quickly access individual parameters at any time. An individual compilation of frequently used parameters can be saved in dedicated user lists.

In addition, the following functions are available for optimization purposes:

- Self-optimization of the controller settings (depending on the drive unit)
- Trace

Diagnostics functions provide information about:

- Control/status words
- Parameter status
- Operating conditions
- Communication states

Performance features

- User-friendly: Only a small number of settings need to be made for successful first commissioning: The motor starts to rotate
- Solution-orientated, dialog-based user guidance simplifies commissioning.
- Self-optimization functions reduce manual effort required to optimize the drive

Minimum hardware and software requirements

PG or PC with Pentium III min. 800 MHz (recommended > 1 GHz)

512 MB work memory (1 GB recommended)

Screen resolution 1024 × 768 pixels, 16-bit color depth

Free hard disk memory min. 2 GB

Microsoft Windows 2000 SP4

Microsoft Windows 2003 Server SP1, SP2

Microsoft Windows XP Professional SP2, SP3

Microsoft Windows Vista Business SP1 ¹⁾

Microsoft Windows Vista Ultimate SP1 ¹⁾

Microsoft Internet Explorer V6.0 or higher

Integration

The SINAMICS S120/S150/G130/G150 Control Units can communicate with one another via PROFIBUS or PROFINET/Ethernet fieldbus, or alternatively also via a serial RS232 interface, depending on the Control Unit version (DP or PN).

In addition there is also the option of coupling SINAMICS S120/S150/G130/G150 and SINAMICS DC MASTER using SINAMICS Link, for instance, to establish a setpoint cascade.

A PG/PC can be connected to the CU320-2 via PROFIBUS for commissioning and service. There must be a PROFIBUS interface with connecting cable at the PG/PC.

Communication between a CU320-2 and PG/PC can also be established via Ethernet, either using an (optional) CBE20 or the Ethernet interface -X127 on the CU320-2.

Note regarding -X127:

This terminal strip is only intended for communication between PG/PC for service and commissioning purposes.

¹⁾ DCC cannot be used. STARTER can only be used on these operating systems if it does not include the DCC option.

Tools and configuration Engineering software

STARTER commissioning tool

Selection and ordering data

	Order No.
STARTER commissioning tool For SINAMICS and MICROMASTER on DVD-ROM German, English, French, Italian, Spanish	6SL3072-0AA00-0AG0

Accessories

	Order No.
SIMATIC S7 connecting cable RS232 null modem cable, 6 m	6ES7901-1BF00-0XA0
PROFIBUS communications module CP 5512 PCMCIA type 2 card + adapter with 9-pin SUB-D socket, for Windows 2000/XP Professional and PCMCIA 32	6GK1551-2AA00
SIMATIC DP plug-in cable 12 Mbaud, for PG connection, prefabricated with 2 × 9-pin SUB-D connectors, 3 m	6ES7901-4BD00-0XA0

Options

Overview

Drive Control Chart (DCC) expands the scope of device functions by means of freely available closed-loop control, arithmetic and logic modules and offers a means by which technological functions can be graphically configured in the SINAMICS S120/S150/G130/G150 drive systems. DCC is installed as an additional application to the STARTER commissioning tool.

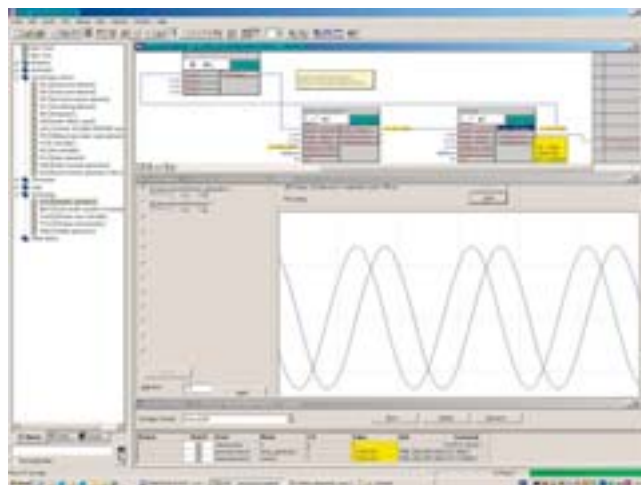
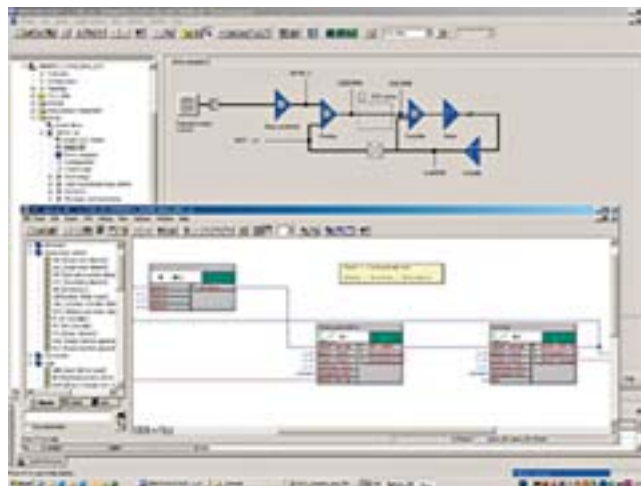

Drive Control Chart expands the facility for the simplest possible configuring of technological functions both for the SIMOTION motion control system as well as for the SINAMICS S120/S150/G130/G150 drive systems. For users, this opens up a new dimension regarding the adaptability of the systems mentioned to the specific functions of their machines. DCC has no restrictions with regard to the number of usable functions; this is only limited by the performance capability of the target platform.

The user-friendly DCC editor enables easy graphical configuration and a clear representation of control loop structures as well as a high degree of reusability of existing diagrams.

Options (continued)

The open-loop and closed-loop control functions are defined by using multi-instance-capable blocks (Drive Control Blocks (DCBs)) from a pre-defined library (DCB library) that are selected and graphically linked with one another by dragging and dropping. Test and diagnostic functions allow the program behavior to be verified and in the case of a fault, the cause identified.

The block library encompasses a large selection of closed-loop, arithmetic and logic function blocks, as well as comprehensive open-loop and closed-loop control functions.

For combining, analyzing and acquiring binary signals, all commonly used logic functions are available for selection (AND, XOR, on/off delay, RS flipflop, counter, etc.). A wide range of arithmetic functions, such as absolute value generation, dividers and minimum/maximum evaluation are available to monitor and evaluate numerical quantities. In addition to the closed-loop drive control, axial winder functions, closed-loop PI controllers, ramp-function generators or wobble generators can be configured simply and easily.

Drive Control Chart for SINAMICS S120/S150/G130/G150 also provides a convenient basis for resolving drive-level open-loop and closed-loop control tasks directly in the converter. This means that SINAMICS can be even more precisely adapted to the particular application. On-site processing in the drive supports modular machine concepts and results in increased overall machine performance.

Minimum hardware and software requirements

See the STARTER engineering software, as DCC is installed in addition to this.

Selection and ordering data

DCC comprises the graphic configuring tool (DCC Editor) and the block library (DCB Library).

The necessary engineering license for each PC (floating) for DCC is acquired at the same time the order is placed; additional runtime licenses are not required.

DCC can be ordered in two versions: as version for SIMOTION and SINAMICS applications, or as version for SINAMICS applications only.

	Order No.
DCC-SIMOTION/SINAMICS V2.0 SP5 for SCOUT/STARTER V4.1 SP5 (single-user license, with DCC data carrier) DCC editor + DCB libraries for use on SIMOTION V4.1 SP5 and SINAMICS S120 V2.6 SP2 / V4.3 SP1 German, English, French, Italian (SIMOTION) German, English, French, Italian, Spanish (SINAMICS)	6AU1810-1JA20-5XA0
DCC-SINAMICS V2.0 SP5 for STARTER V4.1 SP5 (single-user license, with DCC data carrier) DCC editor + DCB library for use on SINAMICS S120/S150/G130/G150 V2.6 SP2 / V4.3 SP1 German, English, French, Italian, Spanish	6AU1810-1HA20-5XA0

Further information

For update purposes, the STARTER commissioning tool can also be downloaded from the Internet at <http://support.automation.siemens.com/WW/view/en/10804985/133100>

Tools and configuration Engineering software

Drive ES engineering system

Overview

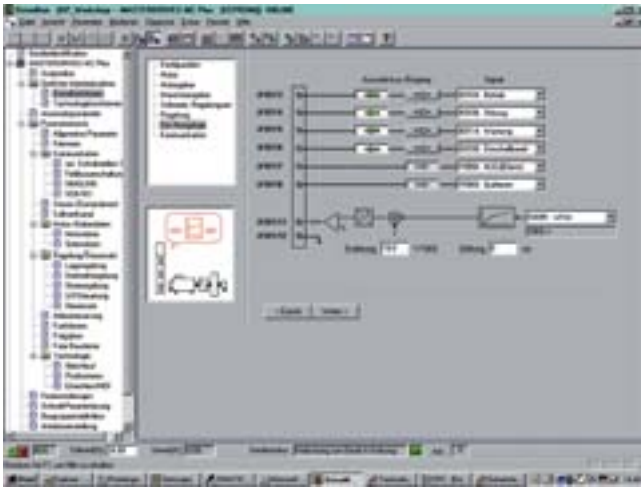

Drive ES is the engineering system used to integrate Siemens drive technology into the SIMATIC automation world easily, efficiently and cost-effectively in terms of communication, configuration and data management.

It is based on the user interface of the STEP 7 Manager, the essential element when it comes to guaranteeing standard and seamless engineering.

Various software packages are available:

- Drive ES Basic – for entry into the world of Totally Integrated Automation and the capability of routing beyond network boundaries and the use of the SIMATIC teleservice.
- Drive ES SIMATIC – to simply parameterize the STEP 7 communication program instead of programming.
- Drive ES PCS7 – integrates drives with PROFIBUS interface into the SIMATIC PCS7 process control system.

Design

- **Drive ES Basic** is the basic software for the parameterization of all drives, online and offline. Using the Drive ES Basic basic software, the automation and the drives can be processed using the SIMATIC Manager software. Drive ES Basic is the starting point for common data archiving for complete projects and for extending the use of routing and also using SIMATIC teleservice for drives. Drive ES Basic provides the engineering tools for the new motion control functions, slave-to-slave communication, equidistant mode and clock cycle synchronization with PROFIBUS DP and ensures that drives with PROFINET IO are simply integrated into the SIMATIC environment.

- **Drive ES SIMATIC** requires that STEP 7 has first been installed. It features a SIMATIC function block library, thereby making the programming of the PROFIBUS and/or PROFINET IO interface in the SIMATIC-CPU for the drives easy and secure.

There is no need for separate, time-consuming programming of the data exchange between the SIMATIC-CPU and the drive.

All Drive ES users need to remember is:

Copy – Modify – Load – Finished.

Customized, fully-developed function blocks are copied from the library into user-specific projects.

Frequently-used functions are set to run in program format:

- Read out complete diagnostics buffer automatically from the drive
- Download complete parameter sets automatically from the SIMATIC CPU into the drive, e.g. when a device has to be replaced.
- Automatically download partial parameter sets (e.g. for recipe and product change) into the drive from the SIMATIC CPU
- Upload the complete parameter assignment or partial parameter sets into the SIMATIC CPU from the drive, i.e. update.

Detailed contents of the Drive ES SIMATIC package:

- **"PROFIBUS DP" communications software** for S7-300 with CPUs with integrated DP interface (function block libraries DRVDPS7, POSMO) S7-400 with CPUs with integrated DP interface or with CP443-5 (function block libraries DRVDPS7, POSMO) and S7-300 with CP342-5 (function block library DRVDPS7C)
- **"USS-Protocol" communications software** for S7-300 with integrated PtP interfaces or with CP340/341 and S7-400 with CP 441 (function block library DRVUSS7)
- **STEP 7 slave object manager** for the easy configuration of drives as well as for non-cyclic PROFIBUS DP communication with the drives; supports the conversion of DVA_S7 to Drive ES projects (V5.1 and higher)
- **STEP 7 device object manager** for convenient configuration of drives with PROFINET IO interfaces (V5.4 and higher)
- **SETUP program** for installing the software in the STEP 7 environment
- **"PROFINET IO" communications software** for S7-300 with CPUs with integrated PN interface, S7-400 with CPUs with integrated PN interface or with CP (DRVDPS7 block library, respectively). PROFINET IO and PROFIBUS DP use the same blocks from the DRVDPS7 library, i.e. the blocks are able to serve both buses with a common block (only for V5.4 and higher)
- **Drive ES PCS7** requires that SIMATIC PCS7 (version 5.2 and higher) has first been installed. Drive ES PCS7 provides a function block library with function blocks for the drives and the corresponding faceplates for the operator station, which enables the drives to be operated from the PCS7 process control system. From version V6.1 and higher, drives will also be able to be represented in the PCS7 Maintenance Station.

Detailed contents of the Drive ES PCS7 package:

- **Block library for SIMATIC PCS7** Faceplates and control blocks for SIMOVERT MASTERDRIVES VC and MC, as well as MICRO-/MIDIMASTER of the 3rd and 4th generation and SIMOREG DC MASTER and SINAMICS
- **STEP 7 slave object manager** for user-friendly configuration of drives and acyclic PROFIBUS DP communications with the drives
- **SETUP program** for installing the software in the PCS 7 environment

Selection and ordering data

	Order No.
<p>Drive ES Basic V5.4 SPx ¹⁾ Configuration software for the integration of drives into Totally Integrated Automation Precondition: STEP 7, V5.3 and higher, SP 3 Supply format: DVD De, En, Fr, It, Es with electronic documentation</p> <ul style="list-style-type: none"> Floating license, 1 user Floating license (copy license), 60 users Update service for single-user license Update service for copy license, 60 users Upgrade from V5.x to V5.4 SPx ¹⁾ 	<p>6SW1700-5JA00-4AA0 6SW1700-5JA00-4AA1 6SW1700-0JA00-0AB2 6SW1700-0JA00-1AB2 6SW1700-5JA00-4AA4</p>
<p>Drive ES SIMATIC V5.4 SPx ¹⁾ Function block library for SIMATIC to parameterize communication with the drives Precondition: STEP 7, V5.3 and higher, SP 3 Supply format: on CD-ROM De, En, Fr, It, Es with electronic documentation</p> <ul style="list-style-type: none"> Single-user license incl. 1x runtime license Runtime license (without data carrier) Update service for single-user license Upgrade from V5.x to V5.4 SPx ¹⁾ 	<p>6SW1700-5JC00-4AA0 6SW1700-5JC00-1AC0 6SW1700-0JC00-0AB2 6SW1700-5JC00-4AA4</p>
<p>Drive ES PCS7 V6.1 SPx ¹⁾ Block library for PCS7 for the integration of drives Precondition: PCS7 from V6.1 and higher Supply format: on CD-ROM De, En, Fr, It, Es with electronic documentation</p> <ul style="list-style-type: none"> Single-user license incl. 1x runtime license Runtime license (without data carrier) Update service for single-user license 	<p>6SW1700-6JD00-1AA0 6SW1700-5JD00-1AC0 6SW1700-0JD00-0AB2</p>
<p>Drive ES PCS7 V7.0 SPx ¹⁾ Block library for PCS7 for the integration of drives Precondition: PCS7 from V7.0 and higher Supply format: on CD-ROM De, En, Fr, It, Es with electronic documentation</p> <ul style="list-style-type: none"> Single-user license incl. 1x runtime license Runtime license (without data carrier) Update service for single-user license Upgrade from V5.x to V7.0 SPx ¹⁾ 	<p>6SW1700-7JD00-0AA0 6SW1700-5JD00-1AC0 6SW1700-0JD00-0AB2 6SW1700-7JD00-0AA4</p>
<p>Drive ES PCS7 V7.1 SPx ¹⁾ Block library for PCS7 for the integration of drives Precondition: PCS7, V7.1 and higher Supply format: on CD-ROM De, En, Fr, It, Es with electronic documentation</p> <ul style="list-style-type: none"> Single-user license incl. 1x runtime license Runtime license (without data carrier) Update service for single-user license Upgrade from V6.x to V7.1 SPx ¹⁾ 	<p>6SW1700-7JD00-1AA0 6SW1700-5JD00-1AC0 6SW1700-0JD00-0AB2 6SW1700-7JD00-1AA4</p>

For further information go to:
www.siemens.com/drivesolutions

Options

Drive ES software update service

A software update service can also be purchased for the Drive ES system. The user will automatically receive the latest software, service packs and full versions for one year after ordering.

The update service can only be ordered in addition to an existing (i.e. previously ordered) full version.

- Duration of the update service: 1 year

The update service is automatically extended by 1 further year unless canceled up to 6 weeks prior to expiration.

	Order No.
<p>Drive ES Basic</p> <ul style="list-style-type: none"> • Update service for single-user license • Update service for copy license 	<p>6SW1700-0JA00-0AB2 6SW1700-0JA00-1AB2</p>
<p>Drive ES SIMATIC</p> <ul style="list-style-type: none"> • Update service for single-user license 	<p>6SW1700-0JC00-0AB2</p>
<p>Drive ES PCS7</p> <ul style="list-style-type: none"> • Update service for single-user license 	<p>6SW1700-0JD00-0AB2</p>

¹⁾ Orders are always automatically supplied with the latest SP

Tools and configuration

Configuration

Engineering Manual

Overview



To professionally select and configure the devices listed in this catalog, we would like to refer to the SINAMICS Low Voltage Engineering Manual. This supplements the SINAMICS Catalogs D 11 · 2011 and D 21.3 · 2011, and is intended to simplify using and handling the SINAMICS series of devices.

This manual is only available as document in an electronic form and only in German and English. It is available as PDF on the CD provided with the catalog.

The Engineering Manual contains a general analysis of the fundamental principles of three-phase variable-speed electric drives as well as detailed system descriptions and specific information about the following units in the SINAMICS range of devices:

- SINAMICS G130 Converter Chassis Units (Catalog D11 · 2011)
- SINAMICS G150 Converter Cabinet Units (Catalog D11 · 2011)
- Modular SINAMICS S120 Chassis Units (Catalogs D 21.3 · 2011 and PM 21 · 2011 / "SINAMICS S120 Drive System")
- Modular cabinet units SINAMICS S120 Cabinet Modules (Catalog D 21.3 · 2011)
- SINAMICS S150 Converter Cabinet Units (Catalog D 21.3 · 2011)

The Engineering Manual is sub-divided into different sections – each with its own specific layout.

The first Chapter – Basics and system description – essentially explains the physical basics of three-phase variable-speed electric drives and provides a generally valid system description of the SINAMICS series of devices.

The second Chapter – EMC Installation Guide – discusses the topic of **E**lectromagnetic **C**ompatibility (EMC) and provides all of the information required to configure and install the above mentioned SINAMICS devices in an EMC-compliant fashion.

The following chapters – Configuration SINAMICS G130, G150, S120 chassis units, S120 Cabinet Modules and S150 converters – discuss device-specific topics, which go beyond the contents of the generally valid system descriptions.

The information it contains addresses technically qualified and trained personnel. The project engineer is responsible for assessing whether the information provided is sufficiently comprehensive for the application in question. The project engineer also has the final system responsibility for the complete drive or plant.

Appendix



5/2	Training
5/2	SITRAIN
5/3	SINAMICS training courses
5/4	Partners at Industry Automation and Drive Technologies
5/5	Online Services
5/5	Information and Ordering in the Internet and on DVD
5/6	Service & Support
	The unmatched complete service for the entire life cycle
5/8	Index
5/8	Subject index
5/10	Order number index
5/11	Approvals
5/12	Conditions of sale and delivery
	Export regulations

Appendix

Training

SITRAIN

Faster and more applicable know-how: Hands-on training from the manufacturer

SITRAIN® – the Siemens Training for Automation and Industrial Solutions – provides you with comprehensive support in solving your tasks.

Training by the market leader in automation and plant engineering enables you to make independent decisions with confidence. Especially where the optimum and efficient use of products and plants are concerned. You can eliminate deficiencies in existing plants, and exclude expensive faulty planning right from the beginning.



First-class know-how directly pays for itself: In shorter startup times, high-quality end products, faster troubleshooting and reduced downtimes. In other words, increased profits and lower costs.

Achieve more with SITRAIN

- Shorter times for startup, maintenance and servicing
- Optimized production operations
- Reliable configuration and startup
- Minimization of plant downtimes
- Flexible plant adaptation to market requirements
- Compliance with quality standards in production
- Increased employee satisfaction and motivation
- Shorter familiarization times following changes in technology and staff

Contact

Visit our site on the Internet at:

<http://www.siemens.com/sitrain>

or let us advise you personally and request our latest training catalog from:

SITRAIN Customer Support Germany:

Phone: +49 (0) 911 / 895 7575

Fax: +49 (0) 911 / 895 7576

E-Mail: info@sitrain.com

SITRAIN highlights

Top trainers

Our trainers are skilled teachers with direct practical experience. Course developers have close contact with product development, and directly pass on their knowledge to the trainers.

Practical experience

The practical experience of our trainers enables them to teach theory effectively. But since theory can be pretty drab, we attach great importance to practical exercises which can comprise up to half of the course time. You can therefore immediately implement your new knowledge in practice. We train you on state-of-the-art methodically/didactically designed training equipment. This training approach will give you all the confidence you need.

Wide variety

With a total of about 300 local attendance courses, we train the complete range of Siemens Industry products as well as interaction of the products in systems.

Tailor-made training

We are only a short distance away. You can find us at more than 50 locations in Germany, and in 62 countries worldwide. You wish to have individual training instead of one of our 300 courses? Our solution: We will provide a program tailored exactly to your personal requirements. Training can be carried out in our Training Centers or at your company.

The right mixture: Blended learning

"Blended learning" means a combination of various training media and sequences. For example, a local attendance course in a Training Center can be optimally supplemented by a teach-yourself program as preparation or follow-up. Additional effect: Reduced traveling costs and periods of absence.



SINAMICS training courses

Design

Training courses for SINAMICS G150/G130/S150

Here you will find an overview of the training courses available for the SINAMICS G150/G130/S150.

The courses are modular in design and are intended for a variety of target groups as well as individual customer requirements.

The system overview will acquaint decision-makers and sales personnel with the system very quickly.

The configuration course provides all the information you need to configure the drive system.

The basic and follow-up courses are guaranteed to provide all of the technical knowledge service engineers will need for servicing/commissioning motion control applications, communication and cabinet units.

All modules contain as many practical exercises as possible, in order to facilitate intensive and direct training on the drive system and with the tools in small groups.



Title	Target group							Duration	Course code
	Decision-makers, sales personnel	Project managers, project personnel	Programmers	Commissioning engineers, project engineers	Service personnel	Operators, users	Maintenance personnel		
SINAMICS system overview	✓	✓						2 days	DR-SN-UEB
SINAMICS G150/G130/S150 configuration		✓		✓				3 days	DR-SNG-PRJ
Induction motors configuration	✓	✓		✓				3 days	DR-ASM-PRJ
SINAMICS G150/G130/S150 commissioning and service				✓	✓		✓	5 days	DR-SNG-SI
SINAMICS G150/G130/S150 user course						✓	✓	2 days	DR-SNG-B
SINAMICS Communication			✓	✓	✓			5 days	DR-SN-COM

Learning path: SINAMICS G150/G130/S150

Decision makers, sales personnel

SINAMICS system overview

DR-SN-UEB 2 days

Project engineers, project personnel, sales personnel

SINAMICS G150/G130/S150 configuration

DR-SNG-PRJ 3 days

Induction motors configuration

DR-ASM-PRJ 3 days

Service personnel, commissioning engineers

SINAMICS G150/G130/S150 S150 Commissioning and service

DR-SNG-SI 5 days

Operators, users

SINAMICS G150/G130/S150 user course

DR-SNG-B 2 days

Requirement:
Knowledge of SIMATIC S7 corresponding to ST PRO1 or ST SERV1 courses

SINAMICS communication

DR-SN-COM 5 days

G_D011_EN_00069a

Appendix Partners at Industry Automation and Drive Technologies



At Siemens Industry Automation and Drive Technologies, more than 85 000 people are resolutely pursuing the same goal: long-term improvement of your competitive ability. We are committed to this goal. Thanks to our commitment, we continue to set new standards in automation and drive technology. In all industries – worldwide.

At your service locally, around the globe for consulting, sales, training, service, support, spare parts ... on the entire Industry Automation and Drive Technologies range.

Your personal contact can be found in our Contacts Database at: www.siemens.com/automation/partner

You start by selecting a

- Product group,
- Country,
- City,
- Service.



Siemens Industry Automation and Drive Technologies in the WWW

A detailed knowledge of the range of products and services available is essential when planning and configuring automation systems. It goes without saying that this information must always be fully up-to-date.

Siemens Industry Automation and Drive Technologies has therefore built up a comprehensive range of information in the World Wide Web, which offers quick and easy access to all data required.

Under the address

www.siemens.com/industry

you will find everything you need to know about products, systems and services.

Product Selection Using the Offline Mall of Industry

Detailed information together with convenient interactive functions:

The Offline Mall CA 01 covers more than 80 000 products and thus provides a full summary of the Siemens Industry Automation and Drive Technologies product base.

Here you will find everything that you need to solve tasks in the fields of automation, switchgear, installation and drives. All information is linked into a user interface which is easy to work with and intuitive.

After selecting the product of your choice you can order at the press of a button, by fax or by online link.

Information on the Offline Mall CA 01 can be found in the Internet under

www.siemens.com/automation/ca01

or on DVD.

Easy Shopping with the Industry Mall

The Industry Mall is the virtual department store of Siemens AG in the Internet. Here you have access to a huge range of products presented in electronic catalogs in an informative and attractive way.

Data transfer via EDIFACT allows the whole procedure from selection through ordering to tracking of the order to be carried out online via the Internet.

Numerous functions are available to support you.

For example, powerful search functions make it easy to find the required products, which can be immediately checked for availability. Customer-specific discounts and preparation of quotes can be carried out online as well as order tracking and tracing.

Please visit the Industry Mall on the Internet under:

www.siemens.com/industrymall

Appendix Service & Support

The unmatched complete service for the entire life cycle

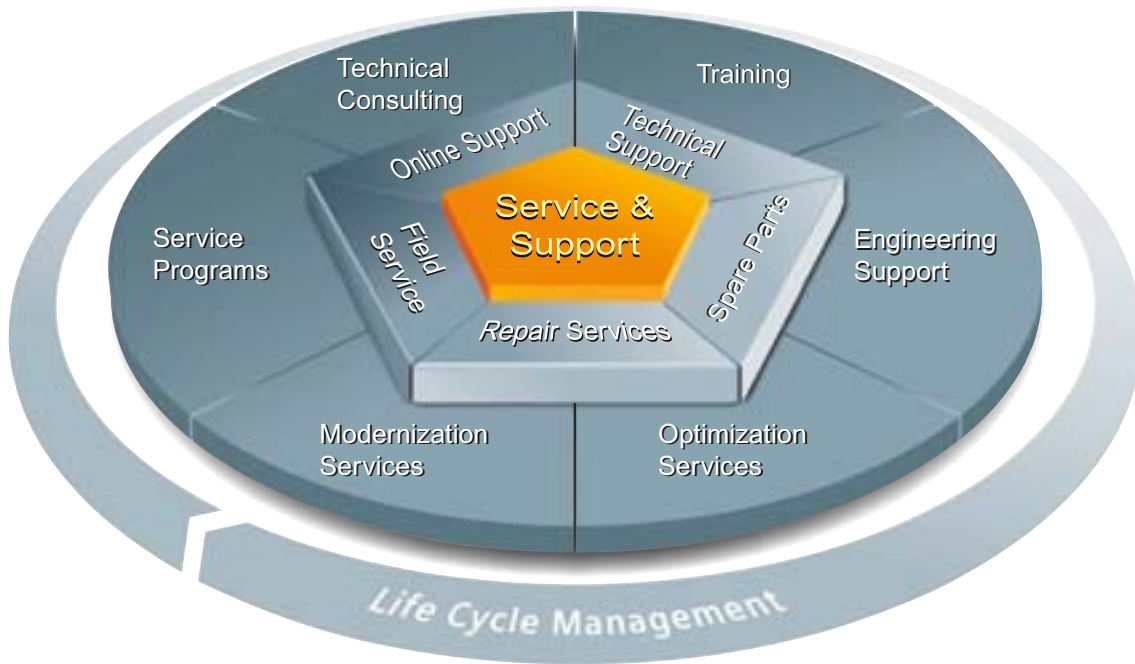

For machine constructors, solution providers and plant operators: The service offering from Siemens Industry, Automation and Drive Technologies includes comprehensive services for a wide range of different users in all sectors of the manufacturing and process industry

To accompany our products and systems, we offer integrated and structured services that provide valuable support in every phase of the life cycle of your machine or plant – from planning and implementation through commissioning as far as maintenance and modernization.

Our Service & Support accompanies you worldwide in all matters concerning automation and drives from Siemens. We provide direct on-site support in more than 100 countries through all phases of the life cycle of your machines and plants.

You have an experienced team of specialists at your side to provide active support and bundled know-how. Regular training courses and intensive contact among our employees – even across continents – ensure reliable service in the most diverse areas.

5

Online Support



The comprehensive online information platform supports you in all aspects of our Service & Support at any time and from any location in the world.

www.siemens.com/automation/service&support

Technical Consulting



Support in planning and designing your project: From detailed actual-state analysis, definition of the goal and consulting on product and system questions right through to the creation of the automation solution.

Technical Support



Expert advice on technical questions with a wide range of demand-optimized services for all our products and systems.

www.siemens.com/automation/support-request

Training



Extend your competitive edge – through practical know-how directly from the manufacturer.

www.siemens.com/sitrain

Contact information is available in the Internet at:
www.siemens.com/automation/partner

The unmatched complete service
for the entire life cycle

Engineering Support



Support during project engineering and development with services fine-tuned to your requirements, from configuration through to implementation of an automation project.

Modernization



You can also rely on our support when it comes to modernization – with comprehensive services from the planning phase all the way to commissioning.

Field Service



Our Field Service offers you services for commissioning and maintenance – to ensure that your machines and plants are always available.

Service programs



Our service programs are selected service packages for an automation and drives system or product group. The individual services are coordinated with each other to ensure smooth coverage of the entire life cycle and support optimum use of your products and systems.

The services of a Service Program can be flexibly adapted at any time and used separately.

Spare parts



In every sector worldwide, plants and systems are required to operate with constantly increasing reliability. We will provide you with the support you need to prevent a standstill from occurring in the first place: with a worldwide network and optimum logistics chains.

Examples of service programs:

- Service contracts
- Plant IT Security Services
- Life Cycle Services for Drive Engineering
- SIMATIC PCS 7 Life Cycle Services
- SINUMERIK Manufacturing Excellence
- SIMATIC Remote Support Services

Advantages at a glance:

- Reduced downtimes for increased productivity
- Optimized maintenance costs due to a tailored scope of services
- Costs that can be calculated and therefore planned
- Service reliability due to guaranteed response times and spare part delivery times
- Customer service personnel will be supported and relieved of additional tasks
- Comprehensive service from a single source, fewer interfaces and greater expertise

Repairs



Downtimes cause problems in the plant as well as unnecessary costs. We can help you to reduce both to a minimum – with our worldwide repair facilities.

Optimization



During the service life of machines and plants, there is often a great potential for increasing productivity or reducing costs. To help you achieve this potential, we are offering a complete range of optimization services.

Contact information is available in the Internet at:
www.siemens.com/automation/partner

Appendix

Index

Subject index

	Part/Page		Part/Page
A			
Advanced Operator Panel AOP30			
SINAMICS G130	2/61		
SINAMICS G150	3/7		
Application	1/2		
SINAMICS G130	2/3		
SINAMICS G150	3/3		
Approvals	5/11		
B			
Basic Operator Panel BOP20	2/60		
Benefits			
SINAMICS G130	2/3		
SINAMICS G150	3/3		
Braking Modules	2/34		
Braking resistors	2/37		
C			
Characteristic curves			
SINAMICS G130	2/11		
SINAMICS G150	3/19		
Closed-loop control functions			
SINAMICS G130	2/6		
SINAMICS G150	3/8		
Conductor cross-sections and terminals	3/41		
Communication with higher-level control and customer Terminal Module			
SINAMICS G130	2/6		
SINAMICS G150	3/8		
Communication Board			
CBC10	2/63		
CBE20	2/64		
Configuration	4/8		
Configuration development at SINAMICS G130	2/5		
Control Unit Kit CD320-2 DP (PROFIBUS)	2/54		
Control Unit Kit CD320-2 PN (PROFINET)	2/57		
D			
DC link components	2/34		
Degrees of protection of cabinet units for SINAMICS G150	3/5		
Derating data			
SINAMICS G130	2/11		
SINAMICS G150	3/19		
Design			
SINAMICS G130	2/3		
SINAMICS G150	3/3		
Directives and standards			
SINAMICS G130	2/9		
SINAMICS G150	3/11		
Documentation			
SINAMICS G130	2/3		
SINAMICS G150	3/28		
Drive Control Chart (DCC)	4/4		
Drive converter chassis units SINAMICS G130	2		
Drive converter cabinet units SINAMICS G150	3		
dv/dt filters plus VPL			
SINAMICS G130	2/43		
SINAMICS G150	3/32		
dv/dt filters compact plus VPL			
SINAMICS G130	2/48		
SINAMICS G150	3/32		
E			
EMC directive			
SINAMICS G130	2/9		
SINAMICS G150	3/11		
Engineering System Drive ES	4/6F		
F			
Function			
SINAMICS G130	2/6		
SINAMICS G150	3/7		
Fuses for SINAMICS G150	3/39		
I			
Information and ordering			
Internet	5/5		
DVD	5/5		
L			
Line filters	2/22		
Line Harmonics Filters for SINAMICS G130	2/25		
Line reactors	2/27		
Line-side power components			
SINAMICS G130	2/22		
SINAMICS G150	3/39		
Load-side power components for SINAMICS G130	2/52		
M			
Members of the SINAMICS family	1/6		
MOTION-CONNECT connection system	2/73		
Motor reactors	2/39		
O			
Online Services	5/5		
Open-loop and closed-loop control functions			
SINAMICS G130	2/6		
SINAMICS G150	3/8		
Options			
SINAMICS G150	3/23		
Option selection matrix	3/25		
Ordering examples	3/26		
Description	3/27		
P			
Parallel circuit for SINAMICS G150	3/6		
Partners at Industry Automation and Drive Technologies	5/4		
Platform concept	1/3		
Power components			
SINAMICS G130	2/22		
SINAMICS G150	3/39		
Power Modules SINAMICS G130	2/14		

	Part/Page		Part/Page
Q			
Quality according to DIN EN ISO 9001	1/3		
R			
Recommended line-side components for SINAMICS G130	2/32		
Recommended fuses for SINAMICS G150	3/39		
S			
Safety Integrated functions			
SINAMICS G130	2/7		
SINAMICS G150	3/9		
Selection an ordering data			
SINAMICS G130	2/14		
SINAMICS G150	3/6		
Sensor Module Cabinet-Mounted SMC30.....	2/72		
Service & Support	5/6		
Signal cables	2/73		
Single circuit for SINAMICS G150	3/6		
SINAMICS			
Members of the SINAMICS family.....	1/6		
SINAMICS G130	1/11		
SINAMICS G150	1/11		
Sine-wave filters for SINAMICS G130.....	2/52		
SIZER	4/2		
SIZER engineering tool.....	4/2		
Software and protective functions			
SINAMICS G130	2/6		
SINAMICS G150	3/8		
STARTER	4/3		
STARTER commissioning tool.....	4/3		
Subject index.....	5/8		
Supplementary system components SINAMICS G130	2/60		
T			
TB30 Terminal Board.....	2/65		
Technical data			
SINAMICS G130	2/9		
SINAMICS G150	3/11		
Terminal Module TM31.....	2/67		
Terminals for SINAMICS G150	3/41		
Terms and conditions of sale and delivery	5/12		
The SINAMICS drive family.....	1/2		
Training.....	5/2		
U			
Overload capability			
SINAMICS G130	2/13		
SINAMICS G150	3/22		
Overview			
SINAMICS G130	2/2		
SINAMICS G150	3/2		
V			
Voltage Sensing Module VSM10	2/70		

Appendix

Index

Order number index

Order No.	Product	Part/Page
3...		
3KL...	Switch disconnectors	2/32
3NA3...	Cable protection fuse, Fuses	2/33, 3/39, 3/40
3NE1...	Cable protection fuse incl. semiconductor protection	2/33, 3/39, 3/40
3RT14...	Line contactor	2/32
3WL1...	Fixed-mounted circuit breaker	2/32
6AU...		
6AU1810-1HA20-5XA0	DCC-SINAMICS V2.0 SP5 for STARTER V4.1 SP5	4/5
6AU1810-1JA20-5XA0	DCC-SIMOTION/ -SINAMICS V2.0 SP5 for SCOUT/STARTER V4.1 SP5	4/5
6ES...		
6ES7901-1BF00-0XA0	RS232 SIMATIC S7 Connecting cable	4/4
6ES7901-4BD00-0XA0	SIMATIC DP plug-in cable	4/4
6ES7972-0B...	PROFIBUS connector	2/54
6F...		
6FC9341-2A.	SUB-D connector, 9-pin	2/63
6FX8002-1AA01-1...	RS232 plug-in cable	2/61
6GK...		
6GK1551-2AA00	PROFIBUS communications module CP 5512	4/4
6GK1901-1...	Industrial Ethernet FC Accessories	2/57, 2/64
6SL3000...		
6SL3000-0B...	Line filters	2/22
6SL3000-0C...	Line reactors	2/28
6SL3000-0J...	Line Harmonics Filter	2/25
6SL3000-1B...	Braking resistor	2/37
6SL3000-2...	Motor reactors	2/39
6SL3000-2C...	Sine-wave filters	2/52
6SL3000-2D...	dv/dt filter plus VPL, dv/dt filter compact plus VPL	2/43, 2/48
6SL304...		
6SL3040-1GA00-1AA0	Control Unit Kit CU320-2 DP PROFIBUS	2/54
6SL3040-1GA01-1AA0	Control Unit Kit CU320-2 PN PROFINET	2/57
6SL305...		
6SL3053-0AA00-3AA0	Voltage Sensing Module VSM10	2/70
6SL3055-0AA00-2CA0	CBC10 Communication Board	2/63
6SL3055-0AA00-2EB0	CBE20 Communication Board	2/64
6SL3055-0AA00-2TA0	TB30 Terminal Board	2/65
6SL3055-0AA00-3AA1	Terminal Module TM31	2/67
6SL3055-0AA00-4BA0	Basic Operator Panel BOP20	2/60
6SL3055-0AA00-4CA4	Advanced Operator Panel AOP30	2/61
6SL3055-0AA00-5CA2	Sensor Module Cabinet-Mounted SMC30	2/72

Order No.	Product	Part/Page
6SL306...		
6SL3060-4A...	Signal cables	2/73
6SL3066-4CA00-0AA0	Dust-proof blanking plugs	2/54, 2/57
6SL307...		
6SL3070-0AA00-0AG0	SIZER engineering tool	4/2
6SL3072-0AA00-0AG0	STARTER commissioning tool	4/3
6SL33...		
6SL3300-1A...	Braking Module	2/34
6SL3310-1G...	Power Module	2/14
6SL37...		
6SL3710-1G...	Drive converter cabinet units SINAMICS G150	3/6
6SW...		
6SW1700-...	Engineering System Drive ES	4/7
6XV...		
6XV18...	Industrial Ethernet FC Accessories	2/57, 2/64

Overview



Many products in this catalog are in compliance with UL/CSA requirements and are labeled with the appropriate certification markings.

All certifications, certificates, declarations of conformance, test certificates, e.g. CE, UL, Safety Integrated have been performed with the associated system components as they are described in the Catalogs and Engineering Manuals.

The certificates are only valid if the products are used with the described system components, are installed according to the Installation Guidelines and are used for their intended purpose.

For cases that deviate from these conditions, the company or person marketing these products is responsible in having the certificates appropriately re-issued.

UL: Underwriters Laboratories
Independent public testing institution in North America

Approval marks:

- **UL** for end-products, tested by UL in accordance with UL standard
- **cUL** for end-products, tested by UL in accordance with CSA standard
- **cULus** for end-products, tested by UL in accordance with UL and CSA standards
- **UR** for mounting parts in end products, tested by UL in accordance with UL standard
- **cUR** for mounting parts in end products, tested by UL in accordance with CSA standard
- **cURus** for mounting parts in end-products, tested by UL in accordance with UL and CSA standards

Test standards:

- SIMOTION: Standard UL 508
- SINAMICS: Standard UL 508C

Product category/File No.:

- SIMOTION: E164110
- SINAMICS: E192450

TUV: TUV Rheinland of North America Inc.
Independent public testing institution in North America
National recognized testing laboratory (NRTL)

Approval mark:

- **cTUVus** tested by TUV in accordance with UL and CSA standards

CSA: Canadian Standard Association
Independent public testing institution in Canada

Approval mark:

- **CSA** Tested by CSA in accordance with CSA standard

Test standard:

- Standard CAN/CSA-C22.2 No. 0-M91/No. 14-05/No. 142-M1987

Conditions of sale and delivery Export regulations

Terms and Conditions of Sale and Delivery

By using this catalog you can acquire hardware and software products described therein from Siemens AG subject to the following terms. Please note! The scope, the quality and the conditions for supplies and services, including software products, by any Siemens entity having a registered office outside of Germany, shall be subject exclusively to the General Terms and Conditions of the respective Siemens entity. The following terms apply exclusively for orders placed with Siemens AG.

For customers with a seat or registered office in Germany

The "General Terms of Payment" as well as the "General Conditions for the Supply of Products and Services of the Electrical and Electronics Industry" shall apply.

For software products, the "General License Conditions for Software Products for Automation and Drives for Customers with a Seat or registered Office in Germany" shall apply.

For customers with a seat or registered office outside of Germany

The "General Terms of Payment" as well as the "General Conditions for Supplies of Siemens Automation and Drives for Customers with a Seat or registered Office outside of Germany" shall apply.

For software products, the "General License Conditions for Software Products for Automation and Drives for Customers with a Seat or registered Office outside of Germany" shall apply.

General

The dimensions are in mm. In Germany, according to the German law on units in measuring technology, data in inches only apply to devices for export.

Illustrations are not binding.

Insofar as there are no remarks on the corresponding pages, – especially with regard to data, dimensions and weights given – these are subject to change without prior notice.

The prices are in € (Euro) ex works, exclusive packaging.

The sales tax (value added tax) is not included in the prices. It shall be debited separately at the respective rate according to the applicable legal regulations.

Prices are subject to change without prior notice. We will debit the prices valid at the time of delivery.

Surcharges will be added to the prices of products that contain silver, copper, aluminum, lead and/or gold if the respective basic official prices for these metals are exceeded. These surcharges will be determined based on the official price and the metal factor of the respective product.

The surcharge will be calculated on the basis of the official price on the day prior to receipt of the order or prior to the release order.

The metal factor determines the official price as of which the metal surcharges are charged and the calculation method used. The metal factor, provided it is relevant, is included with the price information of the respective products.

An exact explanation of the metal factor and the text of the Comprehensive Terms and Conditions of Sale and Delivery are available free of charge from your local Siemens business office under the following Order Nos.:

- 6ZB5310-0KR30-0BA1
(for customers based in Germany)
- 6ZB5310-0KS53-0BA1
(for customers based outside Germany)

or download them from the Internet
www.siemens.com/industrymall
(Germany: Industry Mall Online-Help System)

Export regulations

Our obligation to fulfill this agreement is subject to the proviso that the fulfillment is not prevented by any impediments arising out of national and international foreign trade and customs requirements or any embargos and / or other sanctions.

If you transfer goods (hardware and / or software and/or technology as well as corresponding documentation, regardless of the mode of provision) delivered by us or works and services (including all kinds of technical support) performed by us to a third party worldwide, you shall comply with all applicable national and international (re-) export control regulations.

If required to conduct export control checks, you, upon request by us, shall promptly provide us with all information pertaining to particular end customer, destination and intended use of goods, works and services provided by us, as well as any export control restrictions existing.

The products listed in this catalog / price list may be subject to European / German and/or US export regulations.

Therefore, any export requiring a license is subject to approval by the competent authorities.

According to current provisions, the following export regulations must be observed with respect to the products featured in this catalog / price list:

AL	<p>Number of the <u>German Export List</u></p> <p>Products marked other than "N" require an export license.</p> <p>In the case of software products, the export designations of the relevant data medium must also be generally adhered to.</p> <p>Goods labeled with an "<u>AL" not equal to "N"</u> are subject to a European or German export authorization when being exported out of the EU.</p>
ECCN	<p><u>Export Control Classification Number</u></p> <p>Products marked other than "N" are subject to a reexport license to specific countries.</p> <p>In the case of software products, the export designations of the relevant data medium must also be generally adhered to.</p> <p>Goods labeled with an "<u>ECCN" not equal to "N"</u> are subject to a US re-export authorization.</p>

Even without a label or with an "AL: N" or "ECCN: N", authorization may be required due to the final destination and purpose for which the goods are to be used.

The deciding factors are the AL or ECCN export authorization indicated on order confirmations, delivery notes and invoices.

Errors excepted and subject to change without prior notice.

Industry Automation, Drive Technologies und Low Voltage Distribution

Further information can be obtained from our branch offices listed in the appendix or at www.siemens.com/automation/partner

Interactive Catalog on DVD	<i>Catalog</i>	Motion Control	<i>Catalog</i>
for Industry Automation, Drive Technologies and Low Voltage Distribution	CA 01	SINUMERIK & SIMODRIVE Automation Systems for Machine Tools	NC 60
Drive Systems		SINUMERIK & SINAMICS Equipment for Machine Tools	NC 61
<u>Variable-Speed Drives</u>		SINUMERIK 828D BASIC T/BASIC M, SINAMICS S120 Combi and 1FK7/1PH8 motors	NC 82
SINAMICS G110, SINAMICS G120 Standard Inverters	D 11.1	SIMOTION, SINAMICS S120 and Motors for Production Machines	PM 21
SINAMICS G110D, SINAMICS G120D Distributed Inverters		SINAMICS S110 The Basic Positioning Drive	PM 22
SINAMICS G130 Drive Converter Chassis Units	D 11		
SINAMICS G150 Drive Converter Cabinet Units		Power Supply and System Cabling	
SINAMICS GM150, SINAMICS SM150 Medium-Voltage Converters	D 12	Power supply SITOP	KT 10.1
SINAMICS S120 Chassis Format Units and Cabinet Modules	D 21.3	System cabling SIMATIC TOP connect	KT 10.2
SINAMICS S150 Converter Cabinet Units			
SINAMICS DCM Converter Units	D 23.1	Process Instrumentation and Analytics	
<u>Three-phase Induction Motors</u>	D 84.1	Field Instruments for Process Automation	FI 01
• H-compact		SIREC Recorders and Accessories	MP 20
• H-compact PLUS		SIPART, Controllers and Software	MP 31
Asynchronous Motors Standardline	D 86.1	Products for Weighing Technology	WT 10
Synchronous Motors with Permanent-Magnet Technology, HT-direct	D 86.2	Process Analytical Instruments	PA 01
DC Motors	DA 12	<i>PDF: Process Analytics, Components for the System Integration</i>	PA 11
SIMOREG DC MASTER 6RA70 Digital Chassis Converters	DA 21.1		
SIMOREG K 6RA22 Analog Chassis Converters	DA 21.2	Safety Integrated	
<i>PDF: SIMOREG DC MASTER 6RM70 Digital Converter Cabinet Units</i>	DA 22	Safety Technology for Factory Automation	SI 10
SIMOVERT PM Modular Converter Systems	DA 45		
SIEMOSYN Motors	DA 48	SIMATIC HMI/PC-based Automation	
MICROMASTER 420/430/440 Inverters	DA 51.2	Human Machine Interface Systems/ PC-based Automation	ST 80/ ST PC
MICROMASTER 411/COMBIMASTER 411	DA 51.3		
SIMOVERT MASTERDRIVES Vector Control	DA 65.10	SIMATIC Industrial Automation Systems	
SIMOVERT MASTERDRIVES Motion Control	DA 65.11	Products for Totally Integrated Automation and Micro Automation	ST 70
Synchronous and asynchronous servomotors for SIMOVERT MASTERDRIVES	DA 65.3	SIMATIC PCS 7 Process Control System	ST PCS 7
SIMODRIVE 611 universal and POSMO	DA 65.4	Add-ons for the SIMATIC PCS 7 Process Control System	ST PCS 7.1
SIMOTION, SINAMICS S120 and Motors for Production Machines	PM 21	<i>PDF: Migration solutions with the SIMATIC PCS 7 Process Control System</i>	ST PCS 7.2
SINAMICS S110	PM 22		
The Basic Positioning Drive		SIMATIC NET	
<u>Low-Voltage Three-Phase-Motors</u>		Industrial Communication	IK PI
IEC Squirrel-Cage Motors	D 81.1		
MOTOX Geared Motors	D 87.1	SIMATIC Sensors	
<u>Automation Systems for Machine Tools SIMODRIVE</u>	NC 60	Sensor Technology for Factory Automation	FS 10
• Motors		Industrial Identification Systems	ID 10
• Converter Systems SIMODRIVE 611/POSMO			
<u>Automation Systems for Machine Tools SINAMICS</u>	NC 61	SINVERT Photovoltaics	
• Motors		Inverters and Components for Photovoltaic Installations	RE 10
• Drive System SINAMICS S120			
<u>Drive and Control Components for Hoisting Equipment</u>	HE 1	SIRIUS Industrial Controls	
<u>Mechanical Driving Machines</u>		SIRIUS Industrial Controls	IC 10
Flender Standard Couplings	MD 10.1	SIRIUS Industrial Controls (selected content from catalog IC 10)	IC 90
		System Solutions	
Low-Voltage Power Distribution and Electrical Installation Technology		Applications and Products for Industry are part of the interactive catalog CA 01	
Protection, Switching, Measuring & Monitoring Devices	LV 10.1		
Switchboards and Distribution Systems	LV 10.2		
GAMMA Building Management Systems	ET G1		
<i>PDF: DELTA Switches and Socket Outlets</i>	ET D1		
SICUBE System Cubicles and Cubicle Air-Conditioning	LV 50		
SIVACON 8PS Busbar Trunking Systems	LV 70		

PDF: These catalogs are only available as pdf files.

Download-Center

PDF versions of the catalogs are available on the Internet at:
www.siemens.com/drives/infocenter

Siemens AG
Industry Sector
Drives Technologies
Postfach 47 43
90025 NÜRNBERG
GERMANY

Subject to change without prior notice
Order No. E86060-K5511-A101-A5-7600
3P.8322.91.02 / Dispo 18402
KG 0411 10.0 E 156 En
Printed in Germany
© Siemens AG 2011

www.siemens.com/sinamics

The information provided in this catalog contains descriptions or characteristics of performance which in case of actual use do not always apply as described or which may change as a result of further development of the products. An obligation to provide the respective characteristics shall only exist if expressly agreed in the terms of contract. Availability and technical specifications are subject to change without notice.

All product designations may be trademarks or product names of Siemens AG or supplier companies whose use by third parties for their own purposes could violate the rights of the owners.

Token fee: 5,00 €